



SRAM

DEALER TECHNICAL MANUAL

gear hub systems

1999



DEALER TECHNICAL MANUAL

gear hub systems

TABLE OF CONTENTS

INTRODUCTION

Who we are & what we make	4
What is Spectro?	5
What is Spectro 3x7?	5
What is Spectro E12?	6
What is Spectro S7?	7
What is Spectro P5?	8
What is Spectro T3?	9
What is Spectrolux V6?	10
Evolution of SRAM internal gear hub systems (old/new names)	10

SUPPORT

Distributors	12
Tech. Support & Warranty	14

TIPS & GUIDELINES

Make it shine	16
-------------------------	----

INSTRUCTIONS

Spectro 3x7	18
Spectro E12	24
Spectro S7	34
Spectro P5	40
Spectro T3	46
Spectro Combi P5/S7 (Integrated Brake Shifter)	53
Spectro System Components:	
– Spectrolux V6	54
– Spectro Front Hubs	56
– Spectro VT 3000/5000 (Front Drum Brake Hubs)	58
– Spectro Brake Lever	61
– Spectro Crank Sets	62
– Spectro Power Chain	63

APPENDIX

Spare Parts	66
Glossary	66

WHO WE ARE & WHAT WE MAKE

SRAM?

SRAM is the second largest bicycle component supplier in the world. Founded in 1988, SRAM's World Headquarters is located in Chicago, Illinois USA. Currently, SRAM has manufacturing facilities in

Ireland, Mexico, Taiwan, and with the purchase of Sachs Bicycle Component, also now has manufacturing in Germany, France, and Portugal.

GRIP SHIFT®

Twist shifters, designed to operate ESP and traditional actuation ratio derailleurs.

ESP®

Rear derailleurs designed only to operate with ESP compatible Grip Shift shifters.

DIRT™

Front and rear derailleurs designed to operate with Grip Shift twist shifters and other traditional actuation ratio shifters.

POWERGLIDE™

Cassettes and cranksets for a majority of applications.



SPECTRO SACHS™

Internal gear hub systems and leisure biking systems.

SRAM BRAKING SYSTEMS™

Brakes & levers for a majority of applications.

POWER HUB™

Hubs for a majority of applications.

SACHS POWERCHAIN™

Chains for all applications.

WHAT IS SPECTRO?

SPECTRO

is a system of perfectly tuned and attractively designed components engineered for utmost comfort.

developed to respond with elegant efficiency through an outstanding gear range, delivering the highest

level of enjoyment, safety and **FREEDOM OF MOVEMENT**

WHAT IS SPECTRO 3x7?

MAXIMUM FREEDOM

A comfortable touring system that can go off road? 3x7 brings the best of both worlds together with the most userfriendly 21-speed derailleur system on the market.

Featuring a single front chainring, all 21 speeds are shifted at the rear making every gear easily available at all times. Whether climbing a hill or shifting at a standstill, 3x7 is the

only 21-speed shifting system that can accomplish both.



SPECTRO 3X7 REAR DERAILLEUR

New design with low friction spring for easier shifting.

SPECTRO 3X7 GRIP

Completely redesigned ergonomic grip cover and dual density stationary for increased comfort.



SPECTRO 3X7 INTERNAL HUB

All 21 gears integrated in the rear hub – easy to shift and control in any situation, when pedaling or at a standstill.

POWER GLIDE CASSETTE

Superior shifting, precision, and durability.



SPECTRO
3X7

WHAT IS SPECTRO E12?

POWERFUL COMFORT

The premium power you receive from the twelve closely spaced gears of the E12 will make you a believer in our ultimate riding system. With performance ranges

like those of a 24-speed derailleur, you can climb and drop gears comfortably and easily with a single twist of your wrist. At a standstill. Under load on a hill. In mud and

rain. Never before has one gearhub offered more smooth cruising power when you want it. Where you want it. Every time.

SPECTRO E12 CLICKSTICK

Makes wheel removal a breeze. quick and easy.



SPECTRO GRIP E12

12 speeds in the palm of your hand. fast intuitive shifting. increased comfort through ergonomic dual diameter and dual density grips.



SPECTRO E12 INTERNAL HUB

The engineering masterpiece – 12 closely spaced gears with a range of 339% – the right gear for every terrain and speed.



SPECTRO
E12

WHAT IS SPECTRO S7?

SUPERIOR LEISURE

The S7 system is proof that everything can be easier. The increased performance and gear range of these seven, finely spaced gears offer unsurpassed reliability

and versatility for all rides of life. Any environment is home, and every challenge can be overcome. Even necessary evils, like removing and refitting the rear wheel, are

easier with the preset gear positions of the mini Clickbox. Free time should be easy time. Even if the rest of the world is being difficult.



SPECTRO S7 INTERNAL HUB

This improved version now offers a 303% gear range, the widest of all 7-speed hubs in the market. The new Spectro matte chrome finish

and design further increases the value and appearance of this reliable system.

SPECTRO GRIP AND SPECTRO COMBI S7

Both shifters feature the new Spectro design with dual diameter, highly comfortable and user friendly dual density shifters.



MINI CLICKBOX

SPECTRO
S7

WHAT IS SPECTRO P5?

HARD WORKING

Like an old pair of blue jeans, only a few things in life can speak to true dependability. One of them is the P5. Proven Reliability. Extra comfort. Unprecedented 5-speed

performance with an enlarged gear range of 251%. And a Mini Clickbox with preset gears guaranteeing quick wheel changes. Like that friend that never complains, this is

the hard working system for daily city riders. Nothing else compares.

SPECTRO P5 INTERNAL HUB

The new spectro design and finish sets a new standard for reliable city/commuter systems



SPECTRO GRIP AND SPECTRO COMBI P5

This ultra comfortable spectro design dual density shifter makes for easy, instant shifting action.



SPECTRO
P5

WHAT IS SPECTRO T3?

CLASSIC SIMPLICITY

The heritage of the T3 system – which has been proven a million times over – is synonymous with the durability and flexibility needed for the urban dweller. Developed and perfected for almost a century,

the 186% gear ratio, the strength of the coaster brake, and the untested dependability of the T3 bring legendary comfort, ease, and safety to a complex world. The newly designed Spectro Grip T3 Shifter

offers increased comfort, responds quickly and precisely from mile one to mile one thousand, making it the perfect system for kids and adults alike.

SPECTRO GRIP T3

Completely new design, matching-super-soft and comfortable grip and stationary, great feel and light action shifting for kids and grownups.



SPECTRO T3 INTERNAL GEAR HUB

The classic. the reliable. the improved one with spectro design

and finish. reduced shifting forces and improved braking power.



SPECTRO CLICK T3

Great ergonomics and functionality for smooth and precise shifting.

SPECTRO BANDIX*

Specifically designed for children's hands with smaller diameter and low shifting forces.

* Available for T3, P5, S7.



SPECTRO
T3

WHAT IS SPECTROLUX V6?

UNIVERSAL DYNAMO

The Spectrolux V6 is the ultimate upgrade for many of our and other hub systems. Optimized for silent operation and elegant efficiency,

the Spectrolux dynamo is an easy decision when contemplating additional simplicities in your life. Rain or shine, this power generator is

designed to work perfectly – without drag or slippage – in any and all weather conditions.

SPECTROLUX V6

Whether on the P5, S7, SRAM powerhubs or Shimano® freehubs, this revolutionary new dynamo sets a new standard in the world of power generators. Highly efficient,

easy to assemble, no drag when not in use. State-of-the-art connectors and safe integration at the rear hub makes the Spectrolux V6 the dynamo of choice.



EVOLUTION OF SRAM INTERNAL GEAR HUB SYSTEMS (OLD/NEW NAMES)



SUPPORT

WORLDWIDE DISTRIBUTORS

UNITED STATES

Action Bicycle USA
217 Washington Avenue - A
Carlstadt, NJ, 07072
Ph: 800.284.2453

Brunswick Bicycles
2275 Half Day Road
Bannockburn, IL, 60015
Ph: 847.940.8777

Bicycle Tech International
3201 B Richards Lane
Sante Fe, NM, 87505
Ph: 800.558.8324

Diamondback
4030 Via Pescador
Camarillo, CA, 93012
Ph: 800.776.7641

Downeast Bicycle Specialists
Porter Road, P.O. Box 226
Fryeburg, ME, 04037
Ph: 800.242.1043

Euro-Asia Imports
3935 FootHill
La Crescenta, CA, 91214
Ph: 818.248.1814

Giant Bicycle, Inc.
737 Artesia Boulevard
Rancho Dominguez, CA, 90220
Ph: 800.874.4268

Great Northwest
2335 North West Savier
Portland, OR, 97210
Ph: 800.927.9242

Hans Johnsen Company
8901 Chancellor Row
Dallas, TX, 75247
Ph: 800.879.1515

The Hawley Company
One Hawley Drive
Lexington, SC, 29073
Ph: 800.822.1985

Island Cycle Supply
425 Washington Avenue North
Minneapolis, MN, 55401
Ph: 800.627.2453

J&B Importers, Inc.
P.O. Box 161859
Miami, FL, 33116
Ph: 800.666.5000

J&B Importers West, Inc.
P.O. Box 1248
Englewood, CO, 80150
Ph: 800.999.9228

J&B Importers Pacific, Inc.
P.O. Box 88808
Seattle, WA, 98138
Ph: 800.627.2453

KHS Inc., Distributor
1264 East Walnut Street
Carson, CA, 90746
Ph: 800.347.7854

The Merry Sales Company
1415 San Mateo Avenue
San Francisco, CA, 94080
Ph: 800.245.9959

Performance Cycle Products
22 South 6th Avenue
Mount Vernon, NY, 10550
Ph: 888.265.1876

Olympic Cycle Supply
5711 West Douglass Avenue
Milwaukee, WI, 53218
Ph: 800.236.8380

Quality Bicycle Products
6400 West 105th Street
Bloomington, MN, 55438
Ph: 800.346.0004

Quantum Bicycle & Fitness
400 Venture Court, Suite 101
Verona, WI, 53593
Ph: 800.545.1229

Quentin Distributors
845 Carol Court
Carol Stream, IL, 60188
Ph: 800.323.1741

Raleigh Bicycle Co., USA
22710 72nd Avenue South
Kent, WA, 98032
Ph: 800.222.5527

Riteway Products
2001 East Dyer
Santa Ana, CA, 92705
Ph: 800.869.9866

Schwinn Cycling and Fitness
1690 38th Street
Boulder, CO, 80301
Ph: 800.245.1649

Seattle Bike Supply
7620 South 192nd
Kent, WA, 98032
Ph: 800.283.2453

Security Bicycle
32 Intersection Street
Hempstead, NY, 11551
Ph: 800.645.2990

Sinclair Imports
2755 Highway 40

Verdi, NV, 89439
Ph: 800.654.8052

Trek Bicycle Corporation
801 West Madison
Waterloo, WI, 53594
Ph: 800.879.8735

United Bicycle Parts
691 Washington Street
Ashland, OR, 97520
Ph: 800.482.1984

Wilson Bicycle Sales
31157 Wiegman Road
Hayward, CA, 94544
Ph: 800.877.0077

World Wide Cycle Supply
100 D Executive Drive
Edgewood, NY, 11717
Ph: 800.330.2550

EUROPE

AUSTRIA

KTM Fahrrad GmbH
Harlochnerstrasse 13
5230 Mattighofen
Ph: +43 7742 409 132
Fx: +43 7742 409 126

BELGIUM

Transmission S.A.
Boulevard du Centenaire 4
1325 Dion-Valmont
Ph: +32 10 24 46 46
Fx: +32 10 24 47 77

CZECH REPUBLIC

vokolek import
rezlerova 308
10900 praha-petrovice
Ph: +420 2692 3399
Fx: +420 2692 3399

Zitny
Cesko-bratske nam. 133/II
29301 Mlada Boleslav
Ph: +420 326 72 22 14
Fx: +420 326 72 22 14

DENMARK

Dan Agentur
Stationsvej 77
5792 Arslev
Ph: +45 65 99 24 11
Fx: +45 65 99 28 42

FINLAND

J. Syväranta Oy
Nervanderinkatu 5E 47/PL 64
F-00101 Helsinki
Ph: +358 9 490 137
Fx: +358 9 493 890

FRANCE

SRAM France
Rue de la Briqueterie
80210 Chepy
Ph: +33 3 22 26 01 00
Fx: +33 3 22 26 01 03

Eurostar, S.A.
Z.I. de la Seiglerie
44270 Machecoul
Ph: +33 2 40 78 24 00
Fx: +33 2 40 02 33 86

SUNN

Z.I. Ouest
31800 St. Gaudens
Ph: +33 561 94 85 71
Fx: +33 561 94 85 72

GERMANY

Hartje
Deichstr. 120-122
27318 Hoya
Ph: +49 4251 8110
Fx: +49 4251 811249

Epple
Mittereschweg 1
87700 Memmingen
Ph: +49 8331 7510
Fx: +49 8331 75197

Bico
E. Wiener Bike parts
GZR
Rabeneick/Schlote
Trisport
Veloring
ZEG

WORLDWIDE DISTRIBUTORS

EUROPE (CONTINUED)

GREECE

Gatsoulis Imports
8, Thessalonikis Street
14342 New filadelfia-athens
Ph: +30 1 25 12 779
Fx: +30 1 25 33 960

HUNGARY

Biker Kft.
Gyepsor u. 1
1211 Budapest
Ph: +36 1278 1021
Fx: +36 1278 1023

ICELAND

Oerninn Hjol LTD.
P.O. Box 8036, Skeifan 11
Reykjavik
Ph: +354 1 88 98 92
Fx: +354 5 88 98 96

ITALY

A.M.G. S.r.l.
Via Piave 10
23871 Lomagna (LC)
Ph: +39 039 5 30 11 67
Fx: +39 039 9 22 02 70

NETHERLANDS

Koch Kleeberg B.V.
Postbus 1069, Dukdalfweg 25
1300 BB Almere
Ph: +31 36 532 05 04
Fx: +31 36 532 25 48

Vertex Cycle Systems

NORWAY

Stians Sport A.S.
Vollveien 13, Bygg D, POB 107
1324 Lysaker
Ph: +47 67 11 00 20
Fx: +47 67 11 00 42

POLAND

giant polska
ul. midgatowa 4
02-796warszawa
Ph: +48 22 645 1434
Fx: +48 22 645 1436

harfa-harryson
ul. kozanowska 38/7
54152 wroclaw
Ph: +48 71 72 15 70
Fx: +48 7 13 27 80 92

PORTUGAL

ciclo coimbroes
parca manuel da silva reis 122
4400 vila nova de gaia
Ph: +351 23 79 4461
Fx: +351 23 06 163

REP. OF IRELAND

Raleigh Ireland Limited
Raleigh House,
Kylemore Road
Dublin 10
Ph: +353 1 626 1333
Fx: +353 1 626 1770

SLOVENIA & CROATIA

Proloco Trade d.o.o.
Partizanska 4
64000 Kranj
Ph: +386 64 38 02 00
Fx: +386 64 38 02 022

SPAIN

Casa Masfererrer
Pol. Ind. Congost-Avda.
San Julian, S/N Apdo Correos 89
E-08400 Granollers
Ph: +34 3 846 34 44
Fx: +34 3 846 53 55

Team Bike

SWEDEN

Vartex
Batterivägen 14
43232 Varberg
Ph: +46 340 850 80
Fx: +46 340 61 11 90

SWITZERLAND

Intercycle
Industriegebiet, Haldemattstr. 3
6210 Sursee
Ph: +41 41 92 66 55 11
Fx: +41 41 92 66 352

Amsler & CO AG
Lindenstraße 16
8245 Feuerthalen
Ph: +41 5 26 59 36 36
Fx: +41 5 26 59 16 90

U.K.

Raleigh P&A
Triumph Road
NG 72 DD Nottingham
Ph: +44 115 9420202
Fx: +44 115 9282044

Fisher
Unit 2, Haslemore Business Centre
Lincolnway off
Lincoln Road
EN 1 1TE Enfield, Middx
Ph: +44 181 8053088
Fx: +44 181 8058821

Chickens & Sons
Bisley Works/Landpark Lane
LU6 2PP Kensworth, Beds
Ph: +44 1582 873583
Fx: +44 1582 873583

AUSTRALIA

Groupe Sportif Pty. Ltd.
20 Harker Street
Burwood, Victoria 3125
Ph: +61.3.9888.9882

Velo-Vita Pty. Ltd.
Unit A, 602-612 Botany Road
NSW 2015 Alexandria
Ph: +61.2.9700.8177

CANADA

Bell Sports Canada
700 Chemin Bernard
Granby, PQ, J2G 9H7
Ph: +1.800.661.1662

Kempter Marketing
1271 St Louis
St Lazare, PQ, J7T 1Z9
Ph: +1.514.424.4600

Norco Products Limited
1465 Kebet Way
Port Coquitlam, BC, V3C 6L3
Ph: +1.800.663.8916

ISRAEL

Hobbys Ltd.
3 dov. Fridman street
52504 ramat gan
Ph: +972 5 2429 905
Fx: +972 3 7323 543

JAPAN

Kawashima Cycle Supply
No. 2-4-2 Kushiya-Cho Higashi
Sakai, Osaka 590
Ph: +81.0722.38.1557

Nichinao Shokai
6-16-8 Sotokanda Chiyodaka
Tokyo 101
Ph: +81.0338.32.6251

NEW ZEALAND

Cycle Supplies
PO Box 33051
Christchurch
Ph: +64.3.338.6803

H.S. White & Sons
7C Anwen Place, East Tamacki
PO Box 58331 Greemouni
Auckland
Ph: +64.9273.7690

SOUTH AFRICA

Adventure Sports Trading
27 Elizabeth Lane, North End
6001 Port Elizabeth
Ph: +27.41.547101

TECH SUPPORT & WARRANTY

WHO TO CALL

For fast SRAM dealer warranty and technical support help, please contact us at the appropriate locations listed hereafter.

(Other Countries: please contact your local distributor.)

NORTH AMERICA

Helpdesk Number:

(800)-346-2928

EUROPE

Dealer Helpdesk Number for the following countries:

- Austria
- Belgium
- Denmark
- France
- Germany
- Italy
- The Netherlands
- Norway
- Sweden
- Switzerland
- United Kingdom

+ 800 / 77 26 43 57
S R A M H E L P

SRAM 2 YEAR WARRANTY

In addition to standard legal warranty entitlements, SRAM components include a two year full warranty beginning on the date of purchase. This warranty is subject to the following conditions:

1. During the warranty period, SRAM components with material or production defects which as a result adversely affect the proper functioning of such components, shall either be repaired or replaced with a functioning SRAM component free of charge, whereby we are free to determine whether repair or replacement should take place. If a component cannot be replaced or repaired, the purchaser shall receive, free of charge, a component of higher value from the current SRAM product line. Defective components which have been replaced become the sole property of SRAM.
2. Any other warranty claims not included in this statement are void. This especially includes any disassembly or assembly costs (for instance by the dealer), which shall not be covered by SRAM.
3. Warranty claims are only valid upon presentation of a proper proof of purchase.
4. Parts subject to normal wear and tear (for example brake sleeves, brake pads, chains etc.) and damage which is caused by improper use, specifically caused by disregard for our assembly and operating instructions, shall not be covered by this warranty. Furthermore, this warranty shall not cover damages caused by the use of parts of different manufacturers or otherwise which are not compatible or suitable for use with SRAM components.
5. The servicing of a valid warranty claim shall neither extend this warranty nor establish a warranty period.
6. If a defect is discovered, please contact the dealer where the bicycle or the SRAM component in question was purchased.

TIPS & GUIDELINES

MAKE IT SHINE!

KEEPING YOUR BIKE CLEAN

Keeping your bike and components clean and correctly lubricated will keep performance high and usually slow down the wear and tear on parts.

HOW THE PROS DO IT

Wanna know how the pros do it? Use mild soap and water and a large sponge or soft brush to gently work off the mud and crud. Then rinse with a clean water sponge bath.

CLEANING OF SHIFTERS

We recommend that the internal cleaning and lubrication of shifters should only be done when shifting performance has deteriorated due to excessive contamination. We have found that, generally, the deterioration of shifting efficiency starts with the contamination of the cable and housing system. This causes high friction buildup in a shifting system and should be examined first.

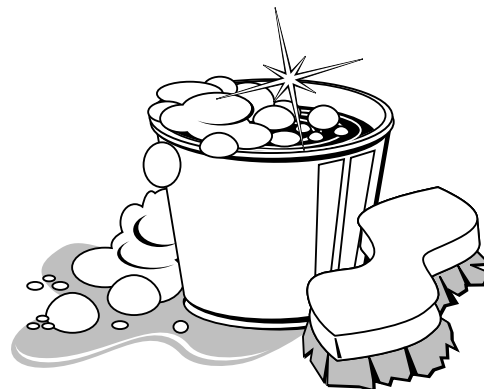

THINK OF RE-LUBRICATING

After the cleaning of any component, always properly re-lubricate if required.

Caution: Be careful how you use degreasers, citrus or otherwise, on your bike components. Degreasers can bloat, soften, or otherwise damage parts.

KEEP THE BIKE ON BOTH WHEELS

Always keep the bike on both wheels when cleaning with water. Hanging the bike vertically or upside down to hose it clean can lead to water drainage into now vulnerable components. Pay and spray? Avoid it. Quick rinses at the

car wash or even spraying with a garden hose can drive contaminants past the sealed mechanisms of your components. This could compromise their performance and shorten their lifespan.

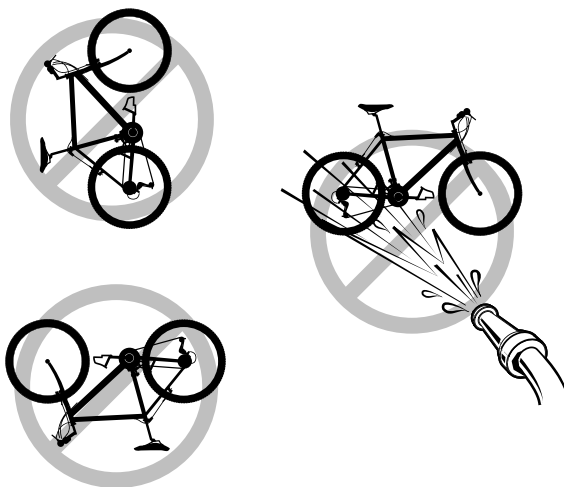

INSTRUCTIONS

SPECTRO 3x7

SPECIFICATIONS

3-speed-hub with 7 speed sprocket cassette

Type MH C3721F

Spectro 3x7 combines the best of the two gear shifting principles – chain (dérailleur) and hub gears – in an intelligent system. Because all 21 speeds are changed on the back wheel the installation of a chain guard on the chain wheel is possible. Gear shifting is performed by means of the ergonomically-designed rotational shifter – Spectro Grip 3x7.

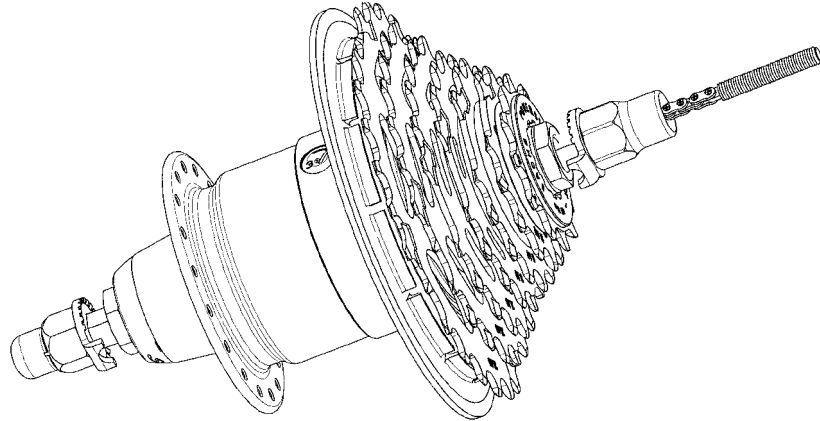

TECHNICAL DATA

3 speed hub (with alu sleeve)

Total ratio: 434 %

(hub with dérailleur gear T=12/28)

Ratio:

Total ratio of hub: 186 %

Gear	Ratio
1	1 : 0.73
2	1 : 1
3	1 : 1.36

Sprocket cassette:

POWER GLIDE 7 speeds, 12/14/16/18/21/24/28 teeth

Crankset:

Spectro single speed, 33 teeth

Spoke length table

Cross	Tire Size								
	47-406 20" x 1.75 x 2	37-490 22" x 1 3/8	47-507 24" x 1.75 x 2	37-540 24" x 1 3/8	47-559 26" x 1.75 x 2	37-590 26" x 1 3/8	47-622 28" x 1.75	32-622 28" x 1 5/8 x 1 1/4	28-630 27" x 1 1/4 fifty
							37-622 28" x 1 5/8 x 1 3/8	28-622 28" x 1 1/8 x 1 3/8	32-630 27" x 1 1/4
3 x	185/182 mm	226/224 mm	234/232 mm	251/249 mm	261/259 mm	275/273 mm	291/289 mm	291/289 mm	295/293 mm

SPECTRO 3x7

ASSEMBLY DATA

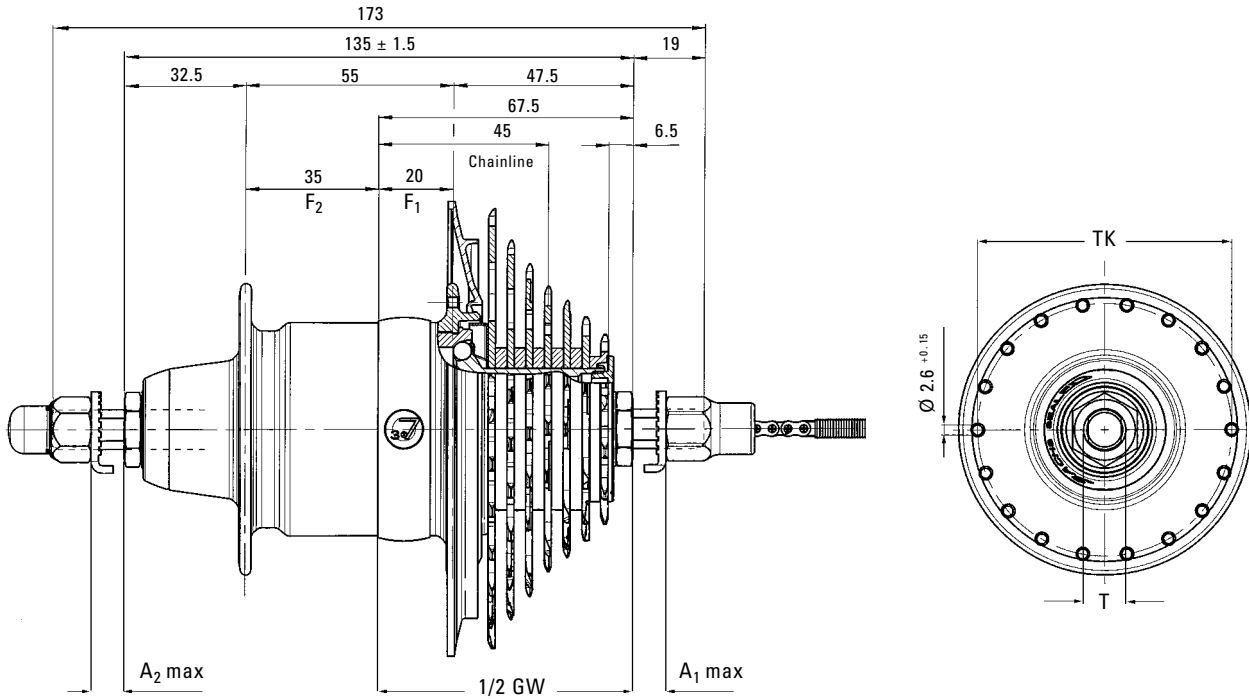

		3x7 MH
Over locknut dimensions	GW ± 1.5	135
Axle ends 2 flat		8.6
Axle thread	T	FG 10.5
Max. dropout width dimensions	A _{1 max}	9.5
Max. dropout width dimensions	A _{2 max}	9.5
Sprockets		7-speed cassette T = 12/28
Chainline at sprocket cassette	CL	45
Spoke hole		36
– Diameter	Ds	2.6 + 0.15
– Ref. circle diameter	TK	67
Spoke flange distance to 1/2 GW	F ₁	20
Spoke flange distance to 1/2 GW	F ₂	35
Axle nut torque		30–40 Nm

Dimensions in mm

instructions

SPECTRO 3x7

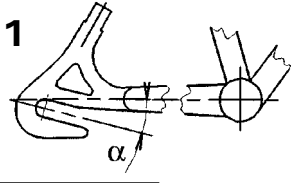

ASSEMBLY REQUIREMENTS

Advice:
Use in tandem not permitted.

Deraillieur gears

The following preconditions apply to the rear dropout for

- a) Assembly with bracket
- The angle (a) between the axle carrier and the centerline of the lower rear wheel fork must be between min. 20° and max. 30° (Fig. 1).
 - If the dimension "max. 9.5" between the smallest sprocket and the outside of the dropout is exceeded a gear unit with an inward offset cranked bracket of type no. 1120 441 020 must be used (Fig. 1a).

- b) Direct mounting (Fig. 2)
- The dropout must be between 4 mm and max. 8 mm thick. Dropouts which are downward opening are permitted.

β	A	B
25°–30°	26...30 mm	6...10 mm

Direct mounting (Fig. 3)

- The distance between the smallest sprocket and the bearing surface of the gear unit on the dropout must be 9–13 mm.

- c) Mounting both with bracket and direct
- The geometry of the seat tube strut and the rear wheel fork in connection with the choice of the smallest sprocket must correspond with the dimensions shown here (see Fig. 4).

Frame – soldered outer stops for cable housings

- The most advantageous combinations of outer stop positions and the required cable housing length can be seen on the following figures and tables.

- a) Fitting to the lower rear wheel fork with bracket mounting (Fig. 5)

X1	80	90	105
cable housing	280	300	330

- b) Fitting to the lower rear wheel fork with direct mounting (Fig. 6).

X2	90	100	115
cable housing	280	300	330

- The inside diameter of the outer stop to carry the cable housing must be 6.05 mm.

Chain guard/chain guide fork

- Chain guard Supplier: (see Fig. 6a)
de woerd bv
Stationsweg 167
Postbus 23
3770 BARNEVELD
The Netherlands
Fon (+31) (0) 3 42-41 21 41
Fax (+31) (0) 3 42-41 21 41

- The chain guide fork (optional; see 11, Fig. 6a) – chainwheel. It is bolted inside the chain guard.

Handlebars

- Rotational shifter
Spectro Grip 3x7
Handlebar diameter 22.0–22.4 mm
Length of straight cylindrical end of handlebars min. 150 mm + width of brake lever clamp

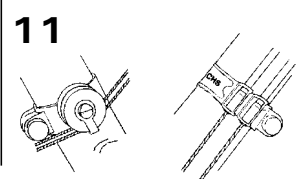
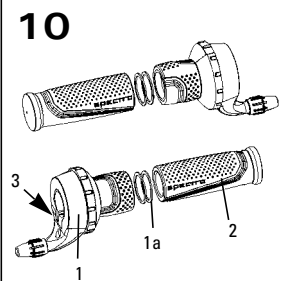
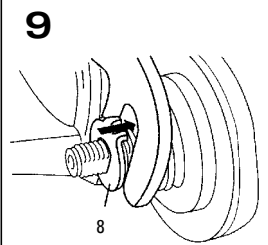
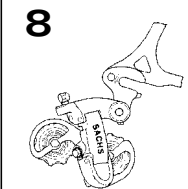
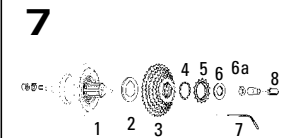
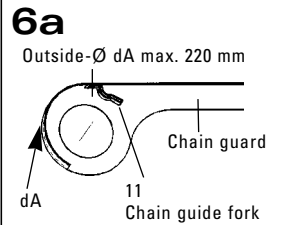
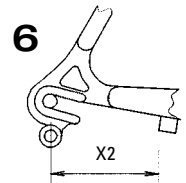
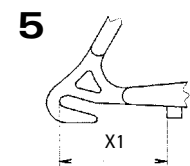
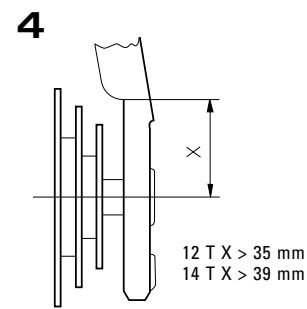
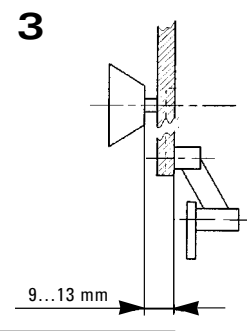
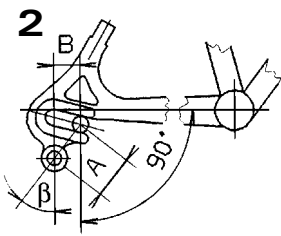
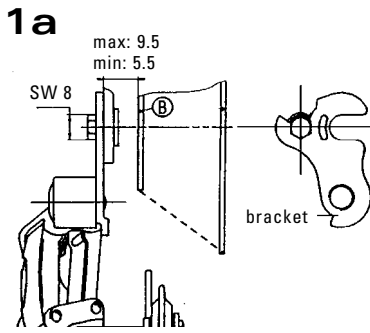

SPECTRO 3x7

12

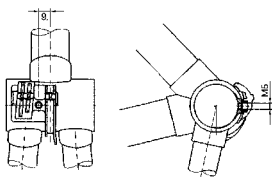

13

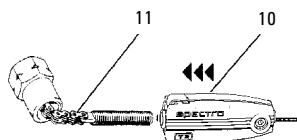

14

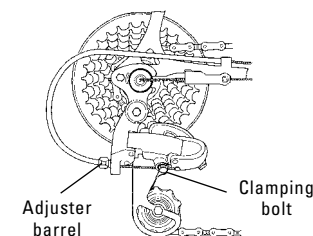

14a

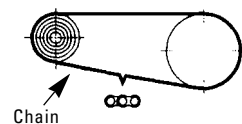

15

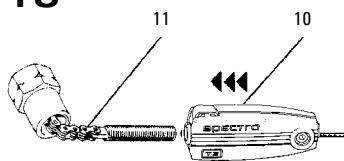

16

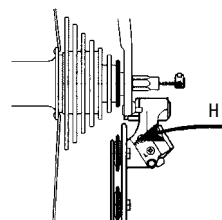

ASSEMBLY

Hub/Derailleur

- Spoke hub as normal (see Spoke length table)
- Place spoke protector disc (1) on shoulder of hub, mount dust cover (2), push sprocket cassette (3) onto driver, fit spacing washer (4) and the smallest sprocket (5) with its shoulder foremost. Screw in ring (6) and tighten up, screw small pull rod (7) into the hub axle (Fig. 7).

If provided push cone disc (6a) onto the axle end on the sprocket side.

- Screw derailleur onto the frame dropout. (Short cage Fig. 8)

Direct mounting:

- 5 mm allen key
- Tightening torque 8–10 Nm

With bracket:

- 8 mm wrench
- Tightening torque 4–5 Nm

- Fit wheel in dropouts and align.
- Place tabbed retaining washers (8) on both sides of the axle – the serrations must bear against the dropout – and the prongs must engage in the dropout slot (Fig. 9).

- Tighten up axle and chain guide nuts. 15 mm wrench, tightening torque 30–40 Nm.

Advice:

When tightening up the chain guide nut (Fig. 13) pull taut the small pull rod 11 so that it isn't damaged.

Rotational shifter

- Slide shifter (1) onto handlebar.
- Slide on the two grip washers (1a).
- Fit fixed grip (2) on the ends.
- Position shifter (1) against the fixed grip (2).
- Align shifter (1) on handlebars and tighten up with clamping bolt (3). 3 mm allen key, tightening torque 1.5 Nm (Fig. 10).

Advice:

Do not use greasy materials when fitting the left and right-hand fixed grips (2) onto the handlebars

- Feed the control cables through the cable housings and the double outer stops. In doing this ensure that the cable housings are located properly into the bottom of the adjuster barrels and the outer stops and that these are tightly screwed to the down tube (Fig. 11). Fit the double pulley clip directly above the bottom bracket on the seat tube and feed the shifter cable over the pulleys to the rear (Fig. 11).

- If a cable guide is fitted beneath the bottom bracket, press the shifter cables in the pregreased pulley guides and route them to the rear – **please do not use open designs**, otherwise the shifter cable could slip out when loose. For assembly a hole is bored in the bottom bracket housing and the cable guide is screwed tight (Fig. 12).
- Connect control cable with hub and derailleur

a) Hub: Set left-hand shifter on handlebars to gear position "3". Feed control cable into juster sleeve (10, Fig. 13), fix it at the appropriate length with the clamping bolt and push it onto the small pull rod (11) until the cable is taut. Cut off any excess cable length. 2.5 mm allen key, tightening torque: 1.5 Nm.

b) Derailleur: Set right-hand shifter on handlebars to gear position "7". Feed shifter cable through outer stop on the lower rear wheel fork and push on cable housing. Then route shifter cable through adjuster barrel and the clamping bolt to the derailleur unit. Pull shifter cable taut and tighten clamping bolt. Make sure that the cable housing is correctly seated in the adjuster barrel and outer stop (Fig. 14).

Determination of chain length (see Fig. 14a)

- Place chain over front chain wheel and the largest rear sprocket and add two chain links.
- Close chain

SHIFTING ADJUSTMENT

Hub

- To adjust, the cable must be tightened up in 3rd gear so as to transmit the shifting movement directly to the hub. Check whether the ends of the cable housings are correctly located in the outer stops.

Adjustment:

- Put shifter into gear position "3", rotate pedals to make sure that the gear is actually engaged.
- Push adjuster sleeve (10) far enough onto the small pull rod (11) until the cable is taut (Fig. 15) but without pulling the small pull rod (11) out of the chain guide nut (12).

Checking:

- Set shifter to gear position "1". Rotate pedals to make sure that 1st gear is actually engaged.
- Check whether the small pull rod can be pulled even further out of the chain guide nut.
- If yes, retension the cable pull, see 1st adjustment.
- Check again.

Advice:

If the adjustment is incorrect a short jerk can occur when starting or there may be a slight creaking noise which may be heard in the drive system (this does not mean that a defect exists).

Derailleur

Presetting the derailleur (best done without the chain)

- Move upper chain guide pulley to beneath the smallest sprocket (and hold it there), then turn the limit screw H in or out until

SPECTRO 3x7

17

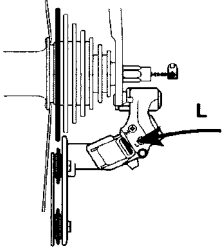

- the guide pulley lines up with the center of the smallest sprocket (*see Fig. 16*).
- Move upper chain guide pulley to beneath the largest sprocket (and hold it there), then turn the limit screw L in or out until the guide pulley lines up with the center of the largest sprocket (*see Fig. 17*).
 - Slowly move the derailleur gear by hand back to below the smallest sprocket.
 - The derailleur is fitted with an adjusting screw which permits the gap between the chain guide pulley and the sprockets to be adjusted. When adjusting with the chain fitted and the upper chain guide pulley below the largest sprocket, set the gap in such a way that when pedalling backwards the pulley just runs clear of the sprocket.

18

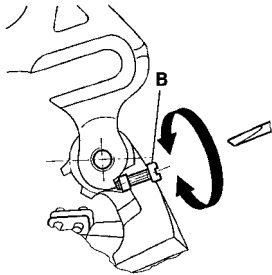

- Fine tuning of the derailleur:
- Set right-hand shifter to gear position "7". This position corresponds with the chain on the smallest sprocket.
 - Rotate pedals. If the chain already touches the 2nd sprocket or if it shifts onto it, screw adjuster barrel 1 (*see Fig. 20*) clockwise until the contact noise stops and the chain shifts back onto the smallest sprocket.
 - Set rotational shifter to gear "6", thereby rotate pedals.
 - If the chain does not shift, turn adjuster barrel (1) in an anti-clockwise direction (*see Fig. 20*), in other words increase the cable tension until the chain shifts correctly onto the 2nd sprocket.

19

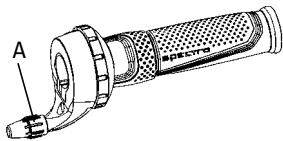

- Checking the gear shifting system:
- Rotate pedals forwards and check by shifting through each of the gears in turn in both directions adjusting as necessary.

Advice:
If in the course of time further adjustments become necessary the adjuster barrel A (*Fig. 19*) on the right-hand rotational shifter can also be used.

20

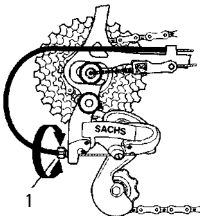

21

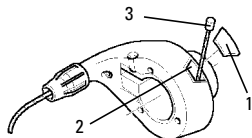

DISMANTLING AND ASSEMBLY OF THE HUB

Dismantling and reassembly of the hub: See the assembly instructions for the free-wheeling hub Spectro T3. The exploded drawing (*Fig. 22*) shows the exact installation position and direction of the individual parts.

MAINTENANCE / SERVICING

Spectro Grip 3x7, cable replacement

- Remove cap (1, *Fig. 21*) from assembly window (2). Turn rotational shifter forwards to its stop until the cable head (3) is visible in the assembly window. Push head out of the cable guide and remove control cable. Insert new control cable, fit on frame accordingly and pull as far as stop in the cable guide on the shifter. Connect control cable with adjuster sleeve or derailleur and close assembly window. Adjustment (*see page 21/22*).

Advice:
When replacing a shifter cable, always replace the cable housing with new, compressionless housing.

Derailleur

- Lubricate slider under bottom bracket (control cable guide).
- Clean chain as necessary and oil lightly.
- Chain links must always be flexible.

Hub

- The 3 speed hub is sufficiently lubricated.
- Oil control cable and small pull rod occasionally.
- Do not apply water under pressure to hub gears when cleaning (e.g. strong water jet, high-pressure cleaner etc.) – if water does penetrate the unit it could lead to functional problems.
- If the side play on the rear wheel is too great arrange for a specialist to adjust the bearings.
- If the bicycle is not used for long periods set the rotational shifter to gear position "3 or 7" to relieve the pressure on the system.

Fig. 22:
Exploded drawing hub

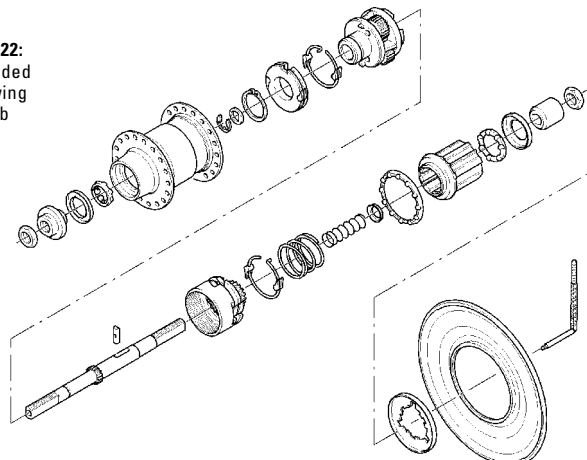

SPECTRO 3x7

TROUBLE SHOOTING GUIDE

Problem	Likely Cause	Corrective Action
Hub:		
Short jerk upon start-up or slight clicking noise (indicator chain moves w/o any gears shifting.	<ul style="list-style-type: none"> Incorrect gear adjustment. 	<ul style="list-style-type: none"> Readjust gears.
Difficulty in shifting	<ul style="list-style-type: none"> Incorrect gear adjustment. 	<ul style="list-style-type: none"> Readjust gears.
		<ul style="list-style-type: none"> Check gear cable routing, lubricate shifter cable if necessary. Clean or replace cable and housing if necessary
Chain hangs loose when freewheeling.	<ul style="list-style-type: none"> Bearings adjusted too tightly 	<ul style="list-style-type: none"> Have bearings adjusted by a specialist.
	<ul style="list-style-type: none"> Loose locknuts. 	<ul style="list-style-type: none"> Same as above.
Derailleur drivetrain:		
Chain shifts beyond smallest rear sprocket against the frame stays.	<ul style="list-style-type: none"> Limit screw H is not screwed in far enough. 	<ul style="list-style-type: none"> Screw in limit screw until the upper pulley is aligned with the smallest sprocket.
Chain shifts poorly or not at all onto the smallest sprocket.	<ul style="list-style-type: none"> Limit screw H is screwed in too far. 	<ul style="list-style-type: none"> Screw out bolt until upper pulley is aligned with the smallest sprocket.
	<ul style="list-style-type: none"> Shifter cable is too tight. 	<ul style="list-style-type: none"> Screw in the limit screw clockwise (or at the right hand shifter) until chain shifts down with ease.
	<ul style="list-style-type: none"> Shifter cable does not slide correctly. 	<ul style="list-style-type: none"> Check shifter cable and lubricate if needed. Clean or replace cable and housing.
	<ul style="list-style-type: none"> Shifter cable housing is too short. 	<ul style="list-style-type: none"> Mount a longer control cable.
Chain shifts beyond largest rear sprocket and drops against the spokes, or the cage plate runs into the spokes.	<ul style="list-style-type: none"> Limit screw L is not screwed in far enough. 	<ul style="list-style-type: none"> Screw in limit screw until upper pulley is aligned with the largest sprocket.
	<ul style="list-style-type: none"> Rear derailleur or derailleur hanger are bent. 	<ul style="list-style-type: none"> Realign or replace.
Chain shifts poorly to larger sprocket, but easily to smaller sprocket.	<ul style="list-style-type: none"> Shifter cable is not taut enough. 	<ul style="list-style-type: none"> Turn adjusting barrel counter-clockwise (or at right hand shifter) until the chain shifts easily to smaller sprocket.
Chain shifts easily to larger sprocket, but poorly to smaller sprocket.	<ul style="list-style-type: none"> Shifter cable is too taut. 	<ul style="list-style-type: none"> Turn adjusting barrel clockwise (or at right hand shifter) until the chain performs downshifts easily.
	<ul style="list-style-type: none"> Shifter cable does not slide correctly. 	<ul style="list-style-type: none"> Check shifter cable and lubricate if needed. Clean or replace cable and housing.
	<ul style="list-style-type: none"> Shifter cable housing is too short. 	<ul style="list-style-type: none"> Mount a longer control cable.

SPECTRO E12

Type MH 12110 with coaster brake
 Type MH 12010 without brake

TECHNICAL DATA / ASSEMBLY REQUIREMENTS

Total ratio:
 Hub: 339%

Single ratio:

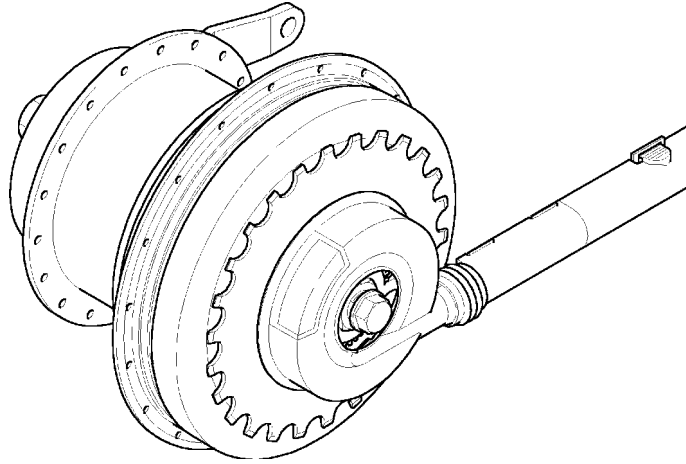

Gear	Gear ratio
1	1 : 0.697 = 1.433
2	1 : 0.851 = 1.174
3	1 : 1 = 1
4	1 : 1.179 = 0.848
5	1 : 1.333 = 0.750
6	1 : 1.481 = 0.675
7	1 : 1.612 = 0.620
8	1 : 1.766 = 0.566
9	1 : 1.915 = 0.522
10	1 : 2.061 = 0.485
11	1 : 2.217 = 0.451
12	1 : 2.364 = 0.423

Distance travelled by one pedal revolution

Gear	Citybike 26" 47-559 (26 x 1.75)	Trekkingbike 28" 37-622 (28 x 13/8 x 15/8)
1	2.09 m	2.23 m
2	2.55 m	2.72 m
3	3.00 m	3.19 m
4	3.53 m	3.77 m
5	4.00 m	4.26 m
6	4.44 m	4.73 m
7	4.83 m	5.15 m
8	5.29 m	5.64 m
9	5.74 m	6.12 m
10	6.18 m	6.59 m
11	6.64 m	7.08 m
12	7.08 m	7.55 m

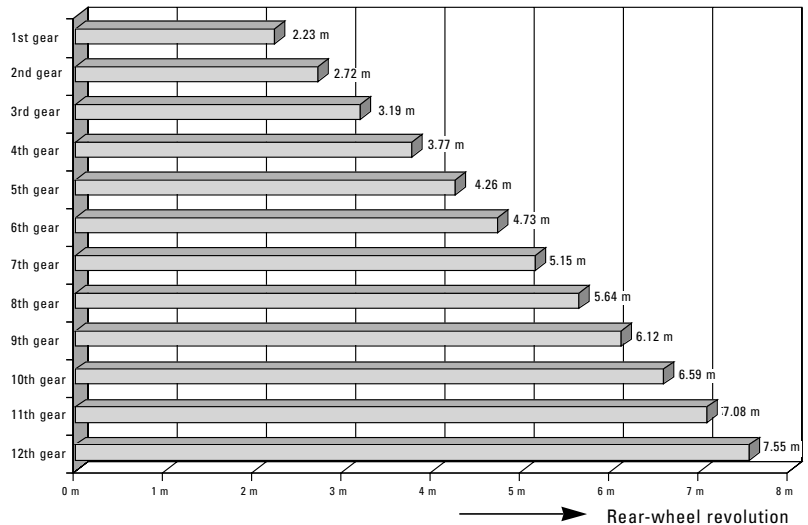

SPECTRO E12

2

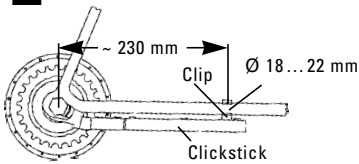

Wheel size:
only 26"/28" wheels are suitable for use.

Chain guard:
available from De Woerd, Netherlands (documents, e.g. installation requirements and assembly instructions, on request).

Bicycle Frame:

- The hub is **not** suitable for tandem use. For other special applications, please contact your nearest dealer or Sachs representative.
- Minimum thickness of dropouts: 4 mm
- Maximum total thickness of axle assembly (i.e. dropout + mudguard stay, etc...): 9 mm
- Additional parts on axle between dropout and hub are **not** allowed.
- The frame geometry in the dropouts area should have enough room (see shaded area) to allow for the installation of hub and its movement into dropouts (*see Fig. 1*).
- **Suggestion: make a trial installation first!**
- It should be possible to remove and replace wheel with inflated tire (Make a trial assembly first!).
- Chainstay Ø 18...22 mm in the clip attachment area of Clickstick (*see Fig. 2*).
- For brake hubs, the frame chainstay must be strong enough to withstand a wheel torque of 250 Nm (2213 in.lbs.).
- Do **not** use frames with vertical or open rear dropouts

Chain/Chain ratio:

- Use exclusively 1/2" x 3/32" roller chain.
- For optimal performance, use a chainring with 38 teeth or more/sprocket with 26 teeth only.

SYSTEM COMPONENTS / ACCESSORIES

- 1 **12-speed hub** (Illustration w/coaster brake, *see Fig. 4 and 5*)
- 2 **Rotational shifter** (delivered in gear position "12" – **Warning** – do not operate before assembly, cable can get clamped and break as a result).
 - a) Shifting cable with continuous cable housing. (Cable housing delivered in following lengths: (L) 1200/1300/1400/1500 mm.)
 - b) Adjustment barrel
 - c) Cable clamp assembly
 - d) Fastening bolt (*see Fig. 6*)
- 3 **Shifter cable – Frame attachment**, 3x on down tube – *see 3, Fig. 3* – if desired 1x at chainstay, i.e. direct mount frame Clamp, (*Fig. 7*) or with bracket (*Fig. 8*), or brazed on parts (Cable housing must be movable in attachment element).
- 4 **Roller chain:** Use 1/2" x 3/32".

3

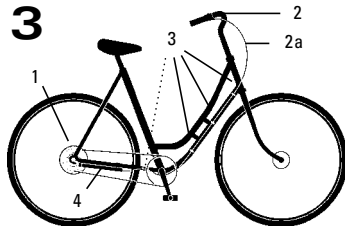

4

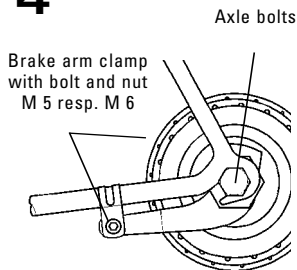

5

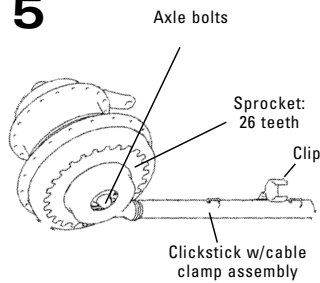

6

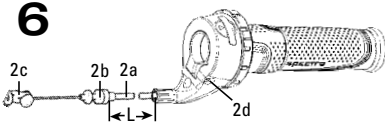

7



8

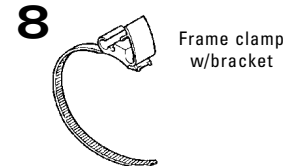

Handlebars for rotational shifters:

- Handlebar diameter 22.0...22.4 mm
- Minimum length of straight area on handlebar: 150 mm + width of brake lever clamp.

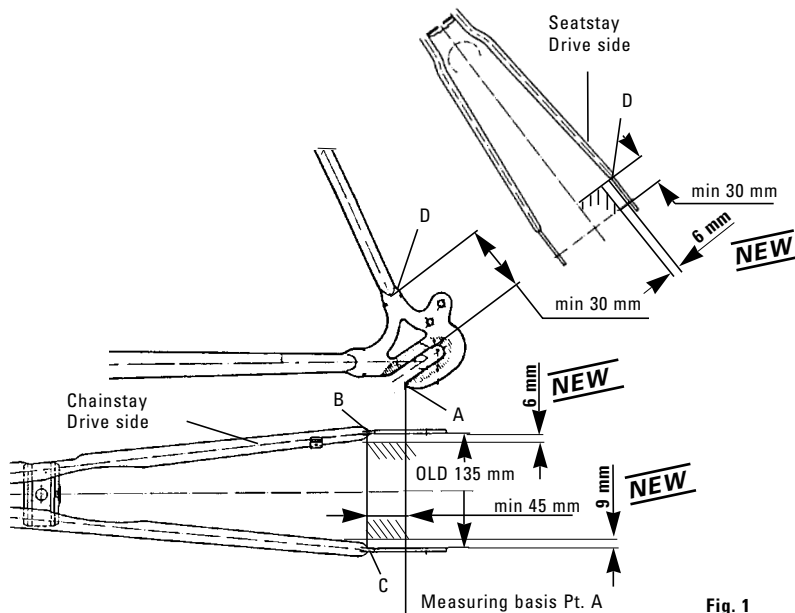
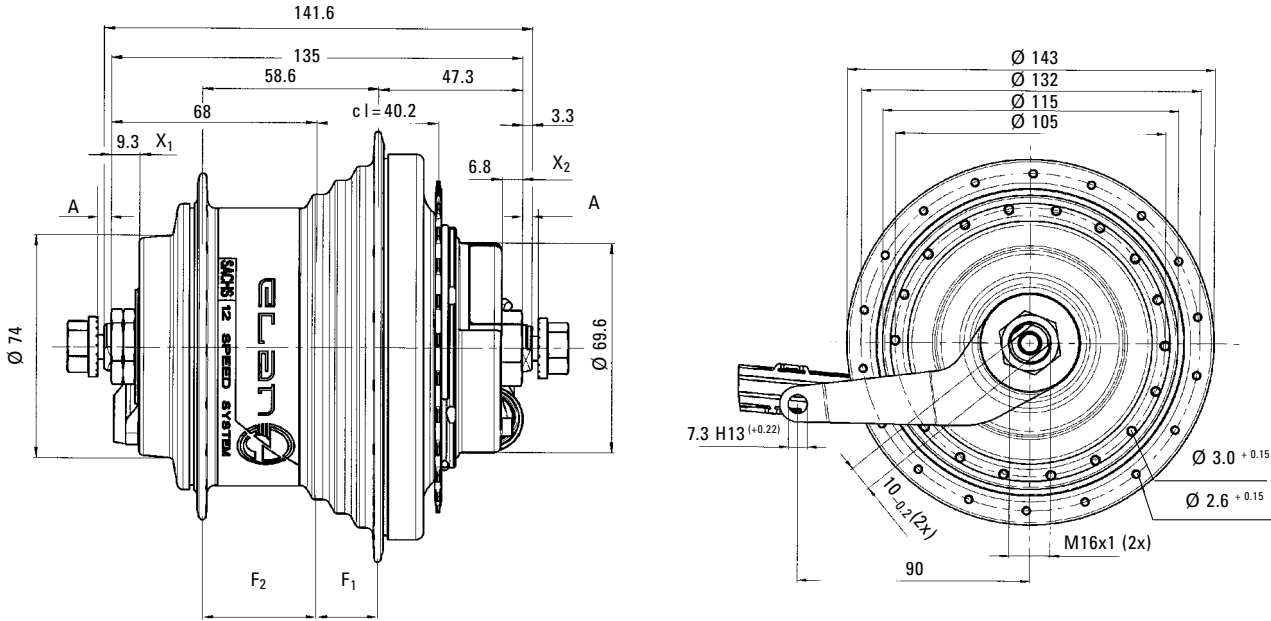

Fig. 1

SPECTRO E12

ASSEMBLY DATA



Spectro E12 with coaster brake MH 12110		
Over locknut dimension		135
Axle length		141.6
Axle ends (projection left & right)		3.3 each
Axle end double (left & right)		10-0.2
Frame droupouts, thickness	A	min. 4, max. 9
Chain line	"cl"	40.2
Chain ratio		only chainring with 38 teeth or more only hub sprocket with 26 teeth
Roller chain		exclusively 1/2" x 3/32"
Spoke hole		36
- Number		
- Diameter		3.0 ^{+0.15} / 2.6 ^{+0.15} (max. spoke diameter: 2.0)
- Circle diameter		105 / 132
Center of hub to center of flange-drive side	F ₁	20.7
Center of hub to center of flange-non-drive side	F ₂	37.9
Counter nut to dust cap distance	X ₁	9.3 (brake lever side)
Counter nut to dust cap distance	X ₂	6.8 (drive side)
Ø Left dust cap		74
Ø Right dust cap		69.6
Torque on axle bolt		30...40 Nm
Torque on brake lever clamp M5		2...3 Nm
Accessories: Clickstick, dust cap, sprocket, circlip, brake arm clamp, 2 axle bolts		

Dimensions in mm

SPECTRO E12

9

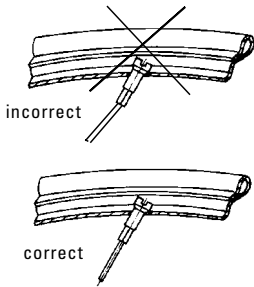

LACING AND INSTALLING HUB

- Maximum spoke diameter: 2.0 mm
- **Please note: Alignment spoke/Nipple**

The high flanged hub results in a relatively tangential running spoke for three crossed spokes. Some rims do not allow for the flat angle of spoke nipple. This results in an undesirable kink between nipple and spoke (see Fig. 9).

In order to make sure that the spoke and nipple align, we recommend the following alternatives:

- Choose the appropriate combination of nipple and rim
- Cross spokes twice instead of 3 times
- Use embossed rims

Spoke length:

- For examples, refer to spoke length table.
- For hub dimension used to determine spoke length, refer to page 26.
- On request, we can determine the most appropriate spoke length for your specific application needs. For this, we would need the dimension for rim Ø "A" (see Fig. 10 – measurement on the basis of two opposing spoke nipple heads).
- Calculated spoke lengths are approximate values. They must be checked through lacing attempts and adjusted accordingly.

Advice:

a tool can be used to hold the hub in the vice. This tool threads into the hub's axle. Tool part No. 00 2324 002 000.

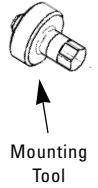

- Place dust cap (1) and sprocket (2) on driver.
- Press sprocket circlip (3) into groove. (Fig. 11)
- Open Clickstick (4). To do so, press ribbed surface of tabs (5) lightly and loosen cap from element (5a).
- Pull cable (6) slightly out of Clickstick (Fig. 12). Shifting adjustment should be done in gear position 12.
- Route cable head through small opening and push through under webs (7) and (7a) in the direction of cable head hanger (8).
- Place head in hanger (8).
- Pull cable (6) and **hold tightly**. Pull red locating wedge (9) from toothing.
- Slowly release cable so the spring can wind up the cable and change the gear from 1 through 12. (Fig. 13).

10

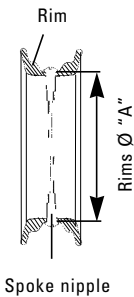

11

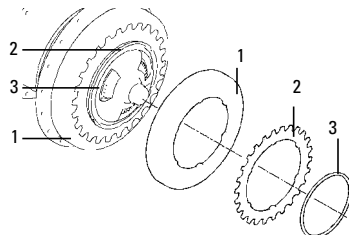

12

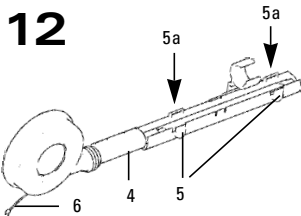

13

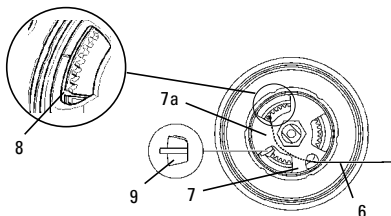

Spoke length table:

Wheel size	26"	26"	28"	28"	28"	28"	28"	28"
Diameter "A" of rim (Fig. 10) measurement on the basis of two opposing spoke nipple heads	545	547	596	606	609	610	611	612
Spoke length when:								
Crossed 2 X								
• right (Large flange)	227.1	228.0	252.0	257.0	258.4	258.9	259.4	259.9
• left (Small flange)	237.5	238.5	262.5	267.4	268.9	269.4	269.9	270.4
Crossed 3 X								
• right (Large flange)	247.2	248.2	272.0	276.9	278.3	278.8	279.3	279.8
• left (Small flange)	353.1	254.0	277.9	282.8	284.3	284.8	285.3	285.8

Dimensions in mm

SPECTRO E12

14

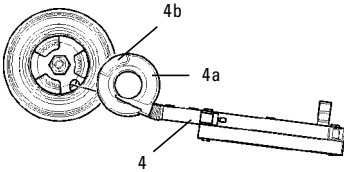

- Bring Clickstick (4) to hub and position the crown (4a) so that red arrow on the hub is visible in the middle of window (4b). By applying a little pressure, snap crown onto hub (**Fig. 14**).

Mounting rear wheel into frame

- Place chain (11) on sprocket (2); fit wheel in rear frame; route ends of axle in the grooves of dropouts; adjust wheel in frame, mount axle bolts (10) with washers **ribbings point towards the dropouts**, and tighten. Use a 15 mm wrench and a torque of 30–40 Nm (266–354 in.lbs.) (**Fig. 15**)

Caution:

Use original bolts only.

Mounting brake arm clamp

- ELAN-Clamp (round, Ø 14, 15, 16 mm) Tighten brake lever clamp (13) so that the centering shoulder (x) fits into the bore on the brake lever (**Fig. 16a**). Screw and nut M5, self-locking. Wrench 8 mm, screwdriver, Torque 2–3 Nm (18–27 in.lbs.).

Caution:

Clamp must sit on frame with absolutely no play!!

- Standard clamp Mount brake lever to the outside of clamp extension. (Do not mount inside of extension, **Fig. 16b**). Screw and nut M6, self-locking. Wrench 10 mm, screwdriver, Torque 2–3 Nm (18–27 in.lbs.).

Caution:

Clamp must sit on frame with absolutely no play!

15

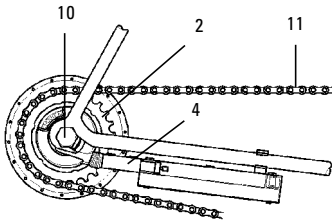

16a

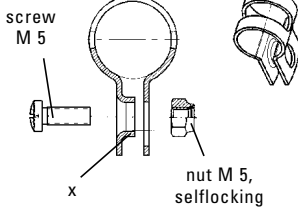
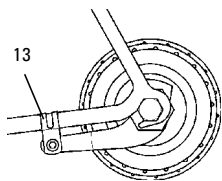

ROTATIONAL SHIFTER AND CABLE

- Slide shifter (1) onto handlebar
- Add 2 thrust washers (3)
- Mount fixed grip (2) onto end of handlebar
- Without applying pressure, slide shifter (1) against fixed grip (2)
- Adjust shifter (1) on handlebar and tighten with bolt (4) with a torque of 1.5 Nm (13 in.lbs.) (**Fig. 17**)

Caution:

Fixed grips on the right and left of handlebar must fit snugly, therefore do not use any lubricants or solvents to install them.

Fixed grips (left and right) provide an axial safety function. For this reason, they should be mounted in such a way as to make sure they do not slip off handlebar.

Caution:

Do not operate shifter before installing and hooking cable to spring shell.

- Place shifter cable along frame as described.
- Put shifter in gear position 12
- Guide cable clamp assembly (5) onto extension bolt of spring shell (6) and snap it in by turning it over (**Fig. 18**)
- Insert adjusting barrel (7) with square nut in the recess (8) inside Clickstick.
- To close cap, slide locking parts (9) in the openings of Clickstick housing and snap in.
- Fasten Clickstick onto chainstay with clamp (12) (**Fig. 19**)
- Check length of shifter cable (maintain relatively narrow cable housing arc (2a)).
- Attachment takes place three times on down tube, (**Fig. 20**). Means of attachment: brazing parts, frame clamps with brackets or direct mount. Avoid clamping of the cable housing and narrow bends. **Cable housing must be movable inside attachment.**

SHIFTING ADJUSTMENT / FINAL CHECK

- To check, shift through all gears (gear 12–gear 1) with rotational shifter. Shifting adjustment must take place in gear position 6.
- **To properly control the cable tension during shifting adjustment, it is necessary to shift to the 1st gear then shift to the 6th which is the shifting adjustment position.**
- Rotate adjusting barrel (7) until the red arrows (10) in window (11) line up (**Fig. 21**).
- Rotate shifter to gear position 7 and back to 6. If adjustment marks no longer line up, check that the cable moves freely and repeat adjustment procedure.
- Spin crank and shift through all gears.
- For the coaster brake hub, check proper function of brake.

DISASSEMBLING AND ASSEMBLING HUB

Disassembly (see detailed drawing on next page)

- Remove snap ring (2), sprocket (3) and dust cover (4).
- Thread tool into axle and clamp in vice (sprocket side).
- Loosen nut (25, 22 mm across flats) while holding flanged nut (24, 32 mm across flats) in position – remove both nuts.
- Disassemble brake arm (23) and remove bearing retainer (22).
- Lift off hub shell (21), remove bearing retainer (20) and brake cylinder (19).
- Remove cir-clip (18)

Caution:

Thrust washer (17), toothed lock washer (16) and locking disc (15) are under spring pressure – take off parts and re-move spring (14).

16b

Pipe clamp from standard range (round or oval, various dimensions), M6 bolt + nut (self-locking)

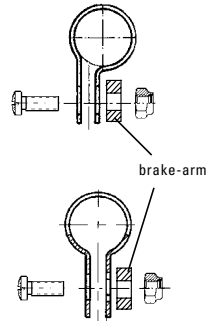

Pipe clamp form standard range (round, Ø 12.5/14/16 mm) M6 bolt + nut (self-locking)

17

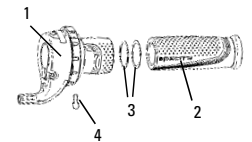

18

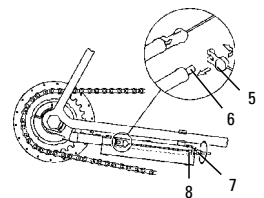

19

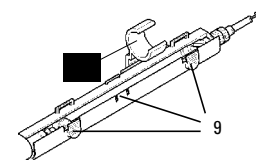

SPECTRO E12

20

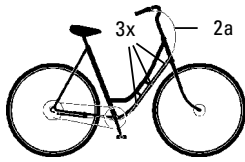

Exploded drawing
Type MH 12110 with
coaster brake

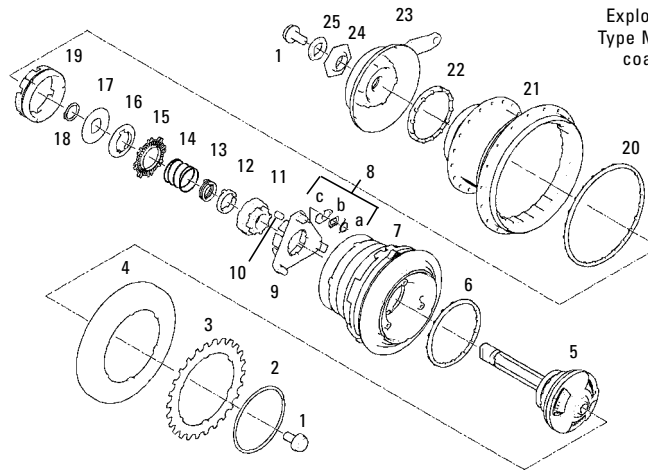

21

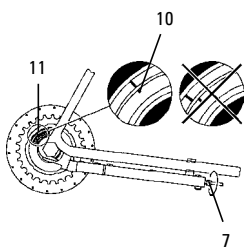

22

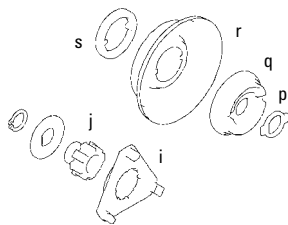

23

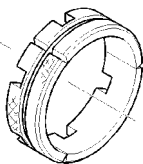

24

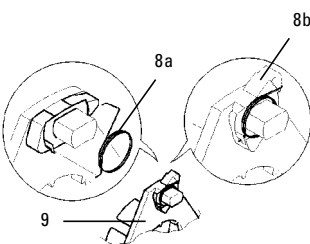

- Pull gear assembly (7) upwards – it will be necessary to exert some force since the friction spring on the axle locks and must be pushed upwards.
- Remove individual parts – friction spring (13), lining (12), brake cam (11), cylindrical rollers (10, 8 rollers), roller guide ring assembly (9) complete with springs, safety devices and pawls (8a,b,c) from the gear block and remove bearing retainer (6) from the Clickbox.

Caution:
When removing the roller guide ring (9), make sure the pawls (8b) have springs attached. If one or more springs are missing, make sure that they are not in the gear box – this could result in future malfunctions.

- In the freewheel version, a coupling sleeve (j, Fig. 22) is fitted instead of parts 10 to 16 in picture above. In addition, the roller guide ring of the freewheel version (i) is a different shape (Fig. 22). In place of brake arm (No. 23), lock washer (p), adjusting cone (q), dust cover (r) and a washer with two lugs on the inside diameter (s) are fitted. See Fig. 22.

Working on individual parts/lubricating parts
Once the hub components have been dismantled, it is also important to take note of the following:

Cleaning parts:

- Only brake components, brake cylinder, brake arms, cylindrical rollers, toothed lock washer, locking disc and roller guide ring with stop notches should be degreased in the cleaning bath. **Do not under any circumstances clean the friction springs with solvent or degreaser.**
- Only clean axle assembly with shifting component and gear assembly on the outside using a paintbrush to prevent degreasing inaccessible lubricating points.

Lubricating parts:

- On the **gears**, wet the inside sun wheel catches and outside ring gear catches with a drop of oil.
- On the **axle with shifting component**, oil the shifting cam rods in the axle profile and around the “prongs” of the shifting sleeve on both sides. Fill each of the four recesses around the circumference of the shifting sleeve with one drop of oil. Using the shift cable, turn the cable pulley several times and make sure it does not jam – all shifting rods in the axle profiles must move at least once. Do not let go of the shifter cable other-wise the cable pulley could fly back at full force (risk of injury).
- Only coat the diamond-patterned side of the brake cylinder with grease. Line the **brake cylinder and bearing shell** for the ball retainer in the hub shell with grease. **Special grease ref. no. 0369 135 100.**
- Grease the toothed side of the toothed lock washer **a little bit.** **Special grease ref. no. 0369 135 100.**
- Thoroughly grease the seat of the friction spring on the axle as well as the inside and outside of the **friction spring** itself (13, Fig. 27). Be sure to use **special grease, ref. no. 0369 148 015.**
- **Wet brake cams, cylindrical rollers and roller guide ring** with a resin-free, acid-free oil.
- Replace faulty or worn parts.
- If worn, i.e. diamond pattern can hardly be seen, the brake cylinder must be replaced. The three brake cylinder segments only fit perfectly on top of one another in one particular order. Therefore it is a good idea to mark the segments before removing the circlip (Fig. 23).
- Correct assembly of springs (8a) for the catches (8c) on the roller guide ring (9, Fig. 24)

SPECTRO E12

34

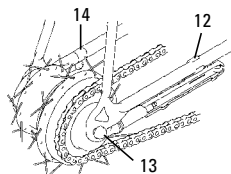

35

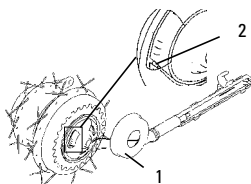

36

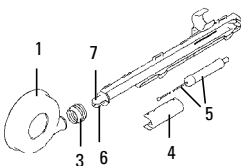

37

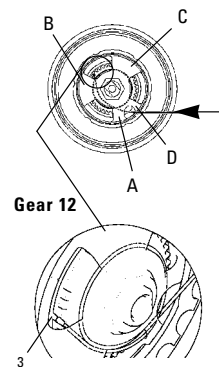

38

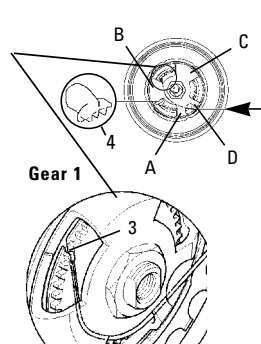

OPERATION / SHIFTING

- Rotational shifter with a fixed grip (1), turning grip (2), shifter body (3), shifter cable with full cable housing, adjusting barrel (4) and cable clamp assembly (5).
- Rotating the turning grip shifts the gears, (2), the selected gear is indicated in the window (6).
- It is also possible to shift under moderate pedalling loads
- Under high load, the spring inside the Clickstick 'pre-loads' for the new gear, allowing the shift only when pedalling force is reduced. It is important to downshift before the increased load of tackling a hill.
- If you do not intend to use your bicycle for an extended period of time, put the shifter in gear position "12" in order to reduce tension in the system. (See Fig. 28.)

SHIFTER CABLE REPLACEMENT

Replacing shifter cable – Clickstick (Fig. 29, 30 and 31)

- Put shifter in gear position "12"
- Open Clickstick by pressing the ribbed surface of tabs (A) lightly and loosen cover from element.
- Remove adjusting barrel (4) with nut out of Clickstick opening and pull the whole shifter cable in the direction of hub. (It may be necessary to loosen cable clips to allow the cable to slide freely.)
- Rotate cable clamp assembly (5) 90° and unhook it from spring shell (7).
- Loosen clamping bolt (8) and pull cable out of clamp assembly (5) and adjusting barrel (4).
- Loosen clamping bolt (9) on the shifter and slide the complete shifter inwards towards the middle of handlebar 20 mm or more. (It may be necessary to loosen and move brake lever.)
- Separate housing (3) from turning grip (2).
- Slide cable head out of guide (10) and remove cable.
- Route new cable through shifter housing and pull cable to seat cable head completely into cable recess.
- Reassemble shifter by aligning four tabs on shifter housing with matching recesses on turning grip and snap together. (Fig. 31)

Caution:
Do not rotate shifter before reconnecting cable to hub.

- To install shifter, slide shifter onto handlebar, followed by 2 grip washers (11) and fixed grip (1). The shifter and fixed grip should be pushed together so the grip washers are squeezed lightly but the turning grip rotates easily. Tighten clamping bolt (9) with a torque of 1.5 Nm (13 in.lbs.) (3 mm Allen key), position brake lever and tighten (Fig. 32).
- Slide cable through cable housing and

adjusting barrel (4) with nut.

- Route cable through opening in clamping bolt (8) and fasten it with a distance of 122.5 mm to adjusting barrel (torque: 1.7–2.5 Nm/15–22 in.lbs.). Cut excess cable to about 0.5 mm (Fig. 33).

Replacing Clickstick – hub cable/ replacing wheel

If the short Clickstick cable is damaged (spring shell to hub), the rear wheel must be removed. This entails observing the following instructions which are also valid for wheel replacement in the case of a flat tire.

- Disconnect shifter cable from Clickstick by unhooking cable clamp assembly (5, Fig. 30)
- Push clip (12) back from chainstay, loosen or unscrew axle bolts (13), remove fastening bolt (14) of brake lever clamp (only for Type MH 12 110), pull wheel from dropouts and remove chain. (Fig. 34).
- For cable replacement, it is a good idea to clamp the wheel in a vice on the axle lock nut.
- Remove the crown cover (1) from hub; the cable head attachment point in the window opposite the smallest opening is now visible. (Fig. 35)
- Using a sharp tool, push cable head (2) out of groove and pull out the cable. (Fig. 35)
- Thread the cable head of the new short cable (5 with attached spring shell) through the cable port of the crown cover opening (1) then secure cable in the hub. (Fig. 36)

In the following paragraphs, 2 variations are described.

1st variation: hub in gear 12 (Fig. 37)

- The hub is in gear position 12; insert cable through the smallest window. Then thread cable around 1 1/2 times clockwise under webs A, B, C and D ...

Caution:

The cable head must be guided under cable where the cable crosses itself.

- ... guide once more under webs A and B all the way through to hanger groove (3) across from smallest window.
- Place cable head and route into opening.

2nd variation: (Fig. 38)

For this procedure the hub is in 1st gear.

- Turn the shifting component via the window against the spring pressure as far as the stop.
- Holding in this position, guide cable through smallest window under webs A and B.
- The hanger groove (3) is across from the smallest window.
- Insert cable head in hanger and pull into groove (3).
- After cable is installed, pull it and hold it tightly; to release locating wedge (4) from gear teeth. (Fig. 38)

SPECTRO E12

39

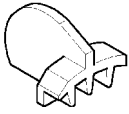

Advice:
Locating wedge is used
(Ref. No. 2324 001 000 – see Fig. 39)

- Slowly release cable (this will allow the spring to wind up the cable and rotate the gears from 1 through 12)
- Bring Clickstick to hub and position the crown cover (1) over the shifter crown so the red arrows on the hub are visible in the middle of the window (1a). By applying a little pressure, snap crown cover onto hub **(Fig. 40)**.
- Slide protective rubber boot (3) over spring shell (5) and crown cover (1).
- Put cable and spring shell in the groove (6) on the Clickstick housing.
- Push Clickstick ball end (7) into crown cover (1). Snap on cover (4) and then engage lip seals of rubber boot into grooves on crown cover and Clickstick. **(Fig. 40)**
- Fit wheel in rear frame and place chain on sprocket. **(Fig. 41)**
- Route ends of axle in the dropout slots, adjust wheel in frame, mount axle bolts (13) and tighten with a torque of 30–40 Nm (266–354 in.lbs.).

Adjustment of shifting (Fig. 44):

- To properly control the cable tension during gear adjustment, it is necessary to shift to 1st gear then shift to the 6th gear adjustment position.
- In the 6th gear position, the two red lines must line up. Rotate adjusting barrel, as necessary (4) until the red arrows line up (16) in window (17).
- Check adjustment from time to time and readjust if necessary. **(Fig. 44)**.

40

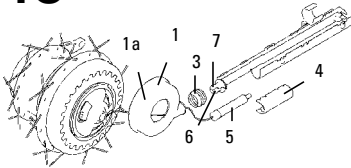

41

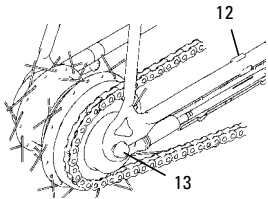

Caution:
Use original bolts only!

42

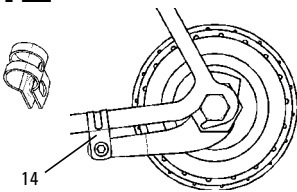

- Chain tension is set correctly when the chain can be lifted about 2 cm in the middle, between chainering and sprocket. Snap clamp (12) onto chainstay **(Fig. 41)**.
- Brake lever clamp screw should be tightened (14) with a torque of 2–3 Nm (18–27 in.lbs.). **(Fig. 42)**

Caution:
Brake lever clamp must fit tightly onto frame, allowing no play.

43

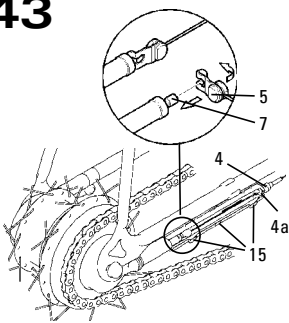

- Connecting shifter cable (Fig. 43):**
- Guide cable clamp assembly (5) onto end of spring shell (7).
 - Insert adjusting barrel (4) nut in the recess (4a) into Clickstick.
 - To close cover, slide locking parts (15) in the openings of Clickstick housing and snap in. **(Fig. 43)**
 - Adjust shifter cable in the cable clips to make sure it runs properly along frame and allows adequate handle-bar rotation. Tighten cable clips as needed. To check, shift through all gears (gear 12–gear 1) with the rotational shifter.

44

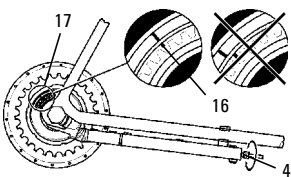

SPECTRO E12

45

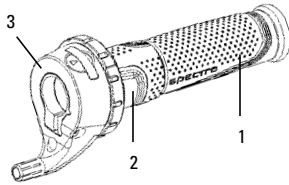

SAFETY / MAINTENANCE / SERVICING

Rotational shifter/Fixed grips

- The rotational shifter consists of three parts (Fig. 45). The shifter body (3) and the fixed grip (1) fit snugly on handlebar, while the turning grip (2) is fitted into housing only.

Caution:

- Fixed grips (left and right) provide an axial safety function. For this reason, they should be mounted in such a way as to make sure they do not slip off handlebar.
- Never use lubricants or solvents to install fixed grips.
- Never ride without the fixed grips. The turning grip may loosen from housing and slip off handlebar – this can result in severe injury or death.
- The shifter is extensively maintenance-free.

Hub

- When cleaning your bike, do not expose hub to compressed water (i.e. high pressure hose, etc.) If water gets into system, malfunction may occur
- The 12-speed hub has been factory lubricated.

Caution:

If the coaster brake becomes overly sensitive or grabs (only for Type MH 12110), the brake shell should be lubricated with the designated lubricant (Art.-No. 0369 135 100). Overheating the hub can lead to lubricant loss and an overly sensitive or grabby brake. For this reason, it is imperative to alternately use the second brake (front wheel brake) when on long and steep rides. This will give the rear brake a chance to cool down.

Caution:

- Locking or skidding wheels can cause a fall which may result in severe injury as well as damage to the bicycle. To avoid this, apply pressure on brake lever or pedals with care to prevent skidding wheels.
- If the rear wheel develops excessive side play, have the bearings read-justed by a professional.

FAULT CHECK LIST

Problem	Cause	Remedy
Riding (pedaling and freewheeling): <ul style="list-style-type: none"> Different clicking noises depending on gear Vibration noises the same in all gears (depending on pedal speed) Scraping noises after riding in rain or on sandy paths Catching or slipping with noises 	<ul style="list-style-type: none"> Pawls are overrunning Axial freewheel (toothed lock washer) degreased Sand grains under dust cover Incorrect gear setting (possibly, intermediate position at turning grip) 	<ul style="list-style-type: none"> If necessary, grease pawl meshing slightly (not catch base) Regrease front of toothed lock washer a little bit Improves with time, otherwise remove dust cover and clean Check gear position and adjust if necessary
Shifting: <ul style="list-style-type: none"> Delayed gear change from 1st–12th Delayed gear change from 12st–1th Shifting noises when changing gear 	<ul style="list-style-type: none"> Control cable in housing stiff or restoring spring too weak Drive force too great, shifting protection activated Direct catch meshing, aluminum shell functions as a resonator 	<ul style="list-style-type: none"> Make sure the control cable runs easily or renew shifting unit Reduce pedal pressure (shift wear-free) If necessary, reduce pedal pressure if noise is disturbing
Braking: <ul style="list-style-type: none"> Strong braking action, possibly with noises, despite low actuating force Squeaking noise just before stopping or when the rear wheel is locked Creaking sound the first time brakes are used after starting off Brake does not grip when pedalling backwards (free travel > 60°) Rear wheel locks after braking and pushing bike backwards 	<ul style="list-style-type: none"> Brake cylinder grease used up Frictional vibration on brake cylinder Clamp on chainstay is loose Torsional play brake lever/lever cone Axial freewheel faulty or incorrectly assembled Accidental twisting of brake caused by gear compensating Turn pedals forwards 	<ul style="list-style-type: none"> Regrease Replace brake cylinder if noise is disturbing Fit clamp without any play Replace arm cone assembly <ol style="list-style-type: none"> Check axial freewheel function Replace friction spring, lining and tooth/locking disc Change into 1st gear or Push bicycle vigorously forwards
Other: <ul style="list-style-type: none"> Slight resistance when pushing bike backwards or spinning wheel 	<ul style="list-style-type: none"> Friction spring on axle is moved 	<ul style="list-style-type: none"> Normal feature of system. If too strong, fit new friction springs with axial freewheel assembly

SPECTRO S7

1

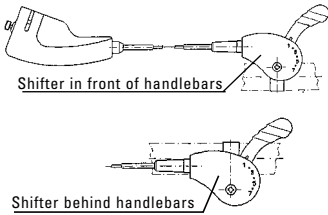

2

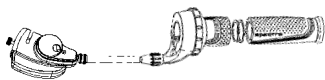

3

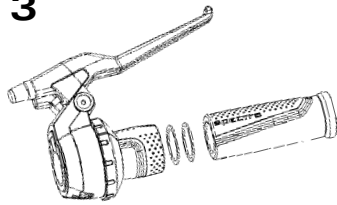

4

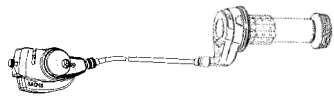

5

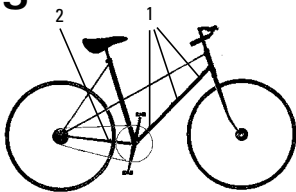

SPECIFICATIONS

Type H 7215 with coaster brake
 Type H 7205 without brake
 Type H 7225 with drum brake

The 7 speed gear hub with the unique gear ratio of 303 % for super-easy cycling. All gears can be selected directly with a shifter. Technology, reliability and safety all correspond with the high levels achieved by the well-proven Sachs hub gear units.

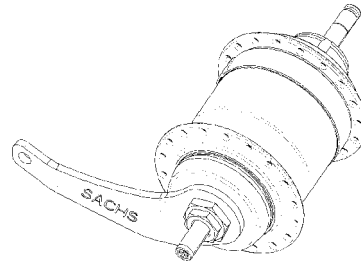

TECHNICAL DATA/ASSEMBLY REQUIREMENTS

Advice: Use in tandem is not permitted.

Hub

Total ratio 303 %

Ratio:

Gear	Ratio
1.	1 : 0.574
2.	1 : 0.677
3.	1 : 0.809
4.	1 : 1
5.	1 : 1.236
6.	1 : 1.476
7.	1 : 1.742

Ratio specification:

Primary 1.83...1.9 for 26" + 28"

Example:

Chain wheel, front $T = 44$
 Rear chain sprocket $T = 24$

Shifter:

Standard shifter consists of:

- humb shifter, in front of/behind handlebar versions (Fig. 1)
- Push-pull-cable
- Clickbox
 Ø Cable housing 4.2 mm
 Ø Clip 22...24 mm, tightening torque of fixing bolts 2.5...3.0 Nm
- Spectro Grip 7 rotational shifter with Mini Clickbox for adults.
 Fixing bolt with 3 mm hex socket head, tightening torque 1.5 Nm. (Fig. 2)

- Spectro Combi 7 rotational shifter with integrated brake lever and Mini Clickbox for adults. Fixing bolt with 4 mm hex socket head, tightening torque 2.5...3 Nm. (Fig. 3)
- Bandix 7 rotational shifter for children/young people (driving wheels from 24"). Fixing bolt with 3 mm hex socket head, tightening torque 1.5 Nm (Fig. 4)

Cycle frame:

- The strength must be such that with a maximum torque of 250 Nm on the driving wheel no residual deformation of the rear structure will occur.
- When fitting the cable avoid small radii – route via the bottom bracket, use 28 mm dia. tube clips for standard frame, Fig. 5 (1)
- Last attachment point is on the lower rear wheel fork immediately behind the chain wheel, 20 mm dia. tube clips for standard frames, Fig. 5 (2)

Chain:

Usable chains 1/2" x 1/8"
 e.g. Power Chain PC1 or 1/2" x 3/32".

Spoke length table

Type	Cross	Tire Size									
		47-406 20" x 1.75 x 2	37-490 22" x 1 3/8	47-507 24" x 1.75 x 2	37-540 24" x 1 3/8	47-559 26" x 1.75 x 2	37-590 26" x 1 3/8	47-622 28" x 1.75	37-622 28" x 1 3/8 x 1 5/8	28-622 28" x 1 1/8	32-622 28" x 1 5/8 x 1 1/4
H 7215/...05	3 x	181 mm	225 mm	232 mm	251 mm	259 mm	275 mm	289 mm	289 mm	289 mm	294 mm
H 7225	3 x	179 mm	222 mm	229 mm	248 mm	256 mm	272 mm	286 mm	286 mm	286 mm	291 mm

SPECTRO S7

ASSEMBLY DATA

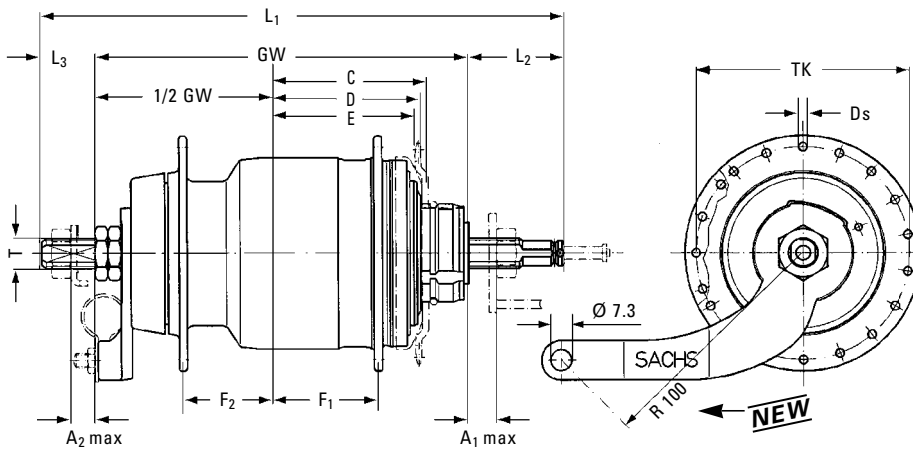

		MH 7215	MH 7205	MH 7225
Coaster brake		X		
Freewheel			X	
Drum brake				X
Fork width	GW	130 mm	132 mm	135 mm
Axle length	L ₁	183.4 mm	183.4 mm	188.5 mm
Axle end, right	L ₂	33.3 mm	33.3 mm	33.3 mm
Axle end, left	L ₃	20 mm	18 mm	20.2 mm
Axle end 2-flats		8.6 mm	8.6 mm	8.6 mm
Axle thread	T	FG 10.5	FG 10.5	FG 10.5
Max. dropout width dimensions	A _{1 max}	11.5 mm	11.5 mm	11.5 mm
Max. dropout width dimensions	A _{2 max}	12 mm	10 mm	12.2 mm
Smallest poss. sprocket (offset)	Pos. C	16	16	16
Smallest poss. sprocket (straight)	Pos. D	18	18	18
Smallest poss. sprocket (offset)	Pos. E	19	19	19
Chain line (offset)	Pos. C	54 mm	55 mm	55.5 mm
Chain line (straight)	Pos. D	51 mm	52 mm	52.5 mm
Chain line (offset)	Pos. E	48 mm	49 mm	49.5 mm
Chain ratio		1.83...1.90 for 26" and 28"		
Spoke hole	– Number	36	36	36
	– Diameter D _s	3.0 mm	3.0 mm	3.0 mm
	– Pitch circle dia. TK	75 mm	75 mm	90 mm
Spoke flange distance to 1/2 GW	F ₁	33 mm	34 mm	34.8 mm
Spoke flange distance to 1/2 GW	F ₂	34 mm	34.5 mm	35.7 mm
Tightening torque on axle nuts			30–40 Nm	
Tightening torque on brake lever clamp		2–3 Nm		2–3 Nm

instructions

SPECTRO S7

6

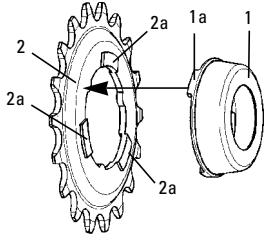

ASSEMBLY

- See spoke length table under “Technical data/assembly requirements” for spoking the hub.

Fit dust cap (optional) (Fig. 6):

- Turn dust cap (1) so that the lugs (1a) are positioned between the three recesses (2a) on the sprocket (2).
- Position dust cap (1) and push it towards the sprocket (2) until it can be felt to engage.
- After positioning the wheel in the rear fork fit non-turn washer (4, Fig. 7) to the outside of the dropout on the brake lever side. The serrations must bear against the dropout and the lug must engage in the dropout slot.
- On the sprocket side fit the protective bracket (1, Fig. 10) directly below the fixing nut. Tightening torque on acorn or hex nuts approx. 35 Nm.
- Fit brake lever tube clamp (5, Fig. 7) Tightening torque: 2–3 Nm.

Caution:

The clamp must be seated on the frame with no play.

Advice:

If a different protective bracket is used the thickness of the attachment plate must be max. 3 mm. Do not use additional washers. A minimum of 1 thread turn X must be visible in front of the axle nut (see Fig. 8)!

Caution:

Max. width of inserts under left axle nut (brake lever side) type 7215 11.5 mm, type 7205 11.5 mm, type 7225 11.5 mm. Max. width of inserts under right axle nut (drive side) type 7215 12 mm, type 7205 10.0 mm, type 7225 12.2 mm.

Next: (see Fig. 9)

- Insert shift rod (3) in shift tube (4) (**oil parts lightly**) and then push into axle bore as far as the stop. Turn slot in shift tube to a position where it is easily visible.
- Push locating sleeve (2) with guiding rib to the front onto the hub axle – making sure that the internal lug is guided in the slot of the shift tube until it can be felt – and heard – to engage.
- Turn locating sleeve on the axle until the guiding rib is facing roughly upwards.
- Push on clickbox (2, Fig. 10) to the stop on the hub axle. The guiding rib of the locating sleeve thereby engages in the slot on the housing. In the end position tighten up the knurled bolt (3, Fig. 10) by hand. Assembly can be performed independently of the gear setting but it is best done at shifter position “1”.

Shifter setting for the thumb shifter/ clickbox version:

Shifter adjustment is not necessary!

Shifter adjustment is also unnecessary following re-assembly!

Shifter setting for the rotational shifter/ Mini Clickbox version:

See “Assembly of rotational shifter/exchange of control cables/shifter adjustment”.

Advice:

Conversion to the Mini Clickbox version is possible without the need to exchange shift rod/tube or locating sleeve.

Removal of rear wheel:

- Loosen knurled bolt
- Pull off clickbox
- Remove locating sleeve, shift tube/rod
- Take out wheel as normal

7

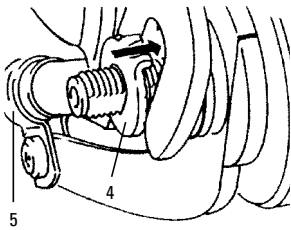

8

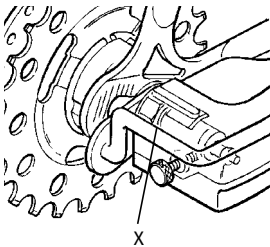

9

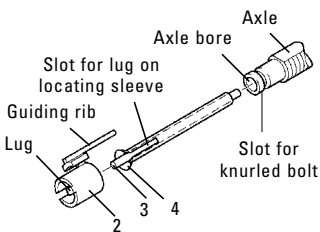

10

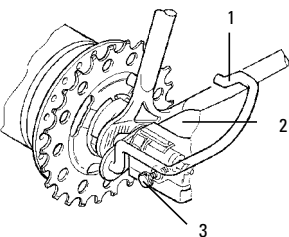

SPECTRO S7

12

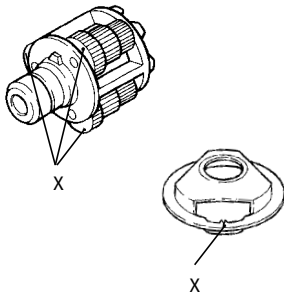
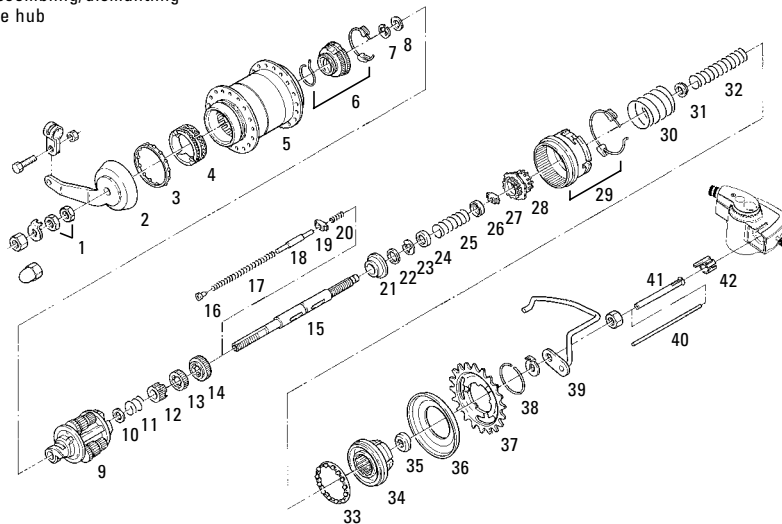

Fig. 11:
Exploded drawing
Assembling/dismantling
the hub



DISMANTLING THE HUB

(see exploded drawing)

- Remove circlip (38) (**Fig. 11**), sprocket (37) and dust cap (36) as normal.

Next:

- Withdraw locating sleeve (42) (latched)
- Take out shift rod/tube (40/41)
- Clamp hub by the axle between aluminium jaws with sprocket side facing downwards.
- Unscrew both locknuts (1)
- Remove lever cone (2) ball retainer (3) and brake shell (4)
- Withdraw hub sleeve (5) upwards
- Unscrew brake cone (6) from flat thread
- Take out retaining washer (7) and thrust washer (8).
- Remove planetary gear carrier (9), washer (10) compression spring (11) and the three sun gears (12, 13, 14).
- Reclamp hub by the axle
- Unscrew fixed cone (35)
- Remove driver (34), compression spring (32) with conical cap (31), large compression spring (30), ball retainer (33), ring gear (29) and coupling gear (28)
- Press spring (25) together and remove thrust block (27).
- Remove conical cap (26), spring (25) and conical cap (24)
- Dismantle crescent-shaped retaining washer (23)
- Remove thrust washer (22) and plastic profile washer (21)
- Unscrew grub screw (16) (**Caution: It is subject to spring pressure**) – and dismantle the long compression spring (17) guide pin (18), thrust block (19) and the short compression spring (20)

HUB ASSEMBLY

(see exploded drawing)

- Insert into the axle (on the side with the internal thread) one after the other:
- Short compression spring (20, **Fig. 11**, "Dismantling the hub")
- Thrust block (19) – it is the same both sides
- Guide rod (18) –it is the same both sides
- Long compression spring (17)
- Press spring together and fit grub screw (16)
- Clamp axle with crank for clickbox facing upwards
- Fit plastic profile washer (21) with its large diameter upwards
- Fit thrust washer (22) and crescent-shaped retaining washer (23)
- Locate conical cap * (24), compression spring (25) with 7 turns, conical cap * (26).
- Press spring together and position thrust block (27) – it is the same both sides – centrally in the axle.
- Reclamp axle (with crank downwards)

Thereafter:

- Fit large sun gear (14), with deflector bevels upwards.
 - Position medium sun gear (13), with deflector bevels upwards.
 - Fit small sun gear (12) – with recesses in front, thrust block engages in the slots.
 - Position smallest compression spring (11)
 - Fit 1 mm thick washer (10)
 - Fit planetary gear carrier (9).
- In doing so:** Place the mounting aid (Fig. 12) on the planetary gear carrier such that the markings (X) on the 3 small planet gears and the mounting aid match up.
- Turn planetary gear carrier and at the same time push it downwards over the sun gears.
 - Fit thrust washer (7) and
 - fit retaining washer (8) in the undercut.

SPECTRO S7

13

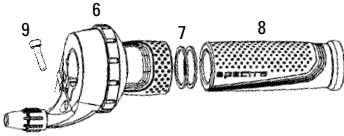

Only now should you remove the mounting aid

Advice:
If the gears are not accurately assembled the hub may feel tight in use. This may lead to sprocket damage during travel.

- Reclamp axle (clickbox crank facing upwards again)
- Fit coupling gear (28) with carrier plate downwards
- Push ring gear (29) over the coupling gear.
- Locate large spring (30)
- Fit largest ball retainer (33) with balls underneath
- Fit conical cap * (31)
- Assemble the compression spring (32) with 12 turns
- Position driver (34) – push it down – and screw on fixed cone (35) to the stop, tightening torque 20 Nm.
- Reclamp axle (clickbox crank facing downwards again)
- Screw brake cone (6) onto the flat thread
- Assemble hub sleeve – with a slight counter-clockwise movement over the pawl ratchet.
- Insert brake shell (4) – retaining lugs upwards, thereby the friction spring on the brake cone must engage in the slot on the brake shell.
- Locate ball retainer (3) (balls underneath), position lever cone (2), thereby turn it clockwise until the retaining lugs engage.
- Screw on locknuts (1), adjust bearing so that there is no play and lock nuts together with 15–20 Nm.

Advice:
The assembly of the hub types H 7205/H 7225 should be carried out in the same way. Difference: Instead of brake shell/cone a click-and-pawl carrier is installed on the planetary gear carrier here. Without flat thread – fixed with a retaining washer. Type 7225 – Exchange of brake anchor plate and brake adjustments, see Point "Type H 7225/Drum brake"

* Always fit the inside of the conical cap to the spring

ASSEMBLY OF ROTATIONAL SHIFTER / EXCHANGE OF CONTROL CABLE / SHIFTER ADJUSTMENT (Mini Clickbox)

Assemble rotational shifter (Fig. 13):

- Push shifter (6) onto handlebar
- Slide on two thrust washers (7)
- Fit fixed grip (8) onto handlebar end
- Place shifter (6) against fixed grip (8).
- Align shifter (6) on the handlebars and tighten up with bolt (9). Tightening torque 1.5 Nm

Advice:

Do not fit right or left-hand fixed grips (8) onto the handlebars with greasy materials.

Dismantling the shifter cable:

(Applies to the Spectro Grip 7/Bandix 7/ Spectro Combi 7)

- Lever off cap (1, Fig. 14) on shifter housing.
- Put rotational shifter in 1st gear. (The cable head of the shifter cable must be visible in the opening).
- Unscrew bolt (2, Fig. 15), remove cap (3).
- Withdraw shifter cable and clamping bolt (6) upwards, loosen clamp and pull clamping piece from cable. (Fig. 17)

Control cable:

- Insert shifter cable through viewing window in gear position "1" (Fig. 14). – Pull shifter cable out through opening in shifter.

Caution:

- Only use shifter cables with a diameter of 1.35 mm art. no. 0391 007 004.
- Screw in completely the adjusting screw on rotational shifter.
- Position clamping bolt (6) at a distance of 68.5 mm, tighten up with 1.5 Nm and cut off cable ends to 2...3 mm (see Fig. 16).
- Fig. 17: Locate clamping bolt (6) and place shifter cable around the carrier cylinder (anti-clockwise winding).
- Insert the square nut of the adjusting bolt (5) in the housing and completely screw in the knurled bolt.

Adjustment:

- Be sure to reset rotational shifter from 5th. to 4th gear
 - Position cap (3) and tighten up with bolt (2).
 - Make sure that the cap on the twistgrip (1, Fig. 14) engages in the shifter housing.
 - Match up the arrow marks in the viewing window (4) of the cap (3) by turning the adjusting screw (5).
- Check the setting from time to time and readjust as necessary.**

Advice:

To set the clamping bolt – adjusting screw distance a setting piece can be used. Order no. 0324 105 000

14

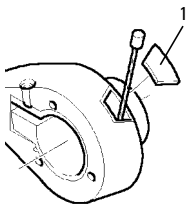

15

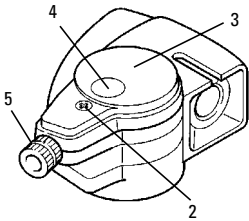

16

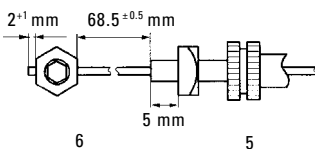

17

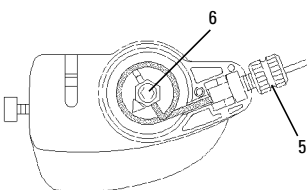

SPECTRO S7

18

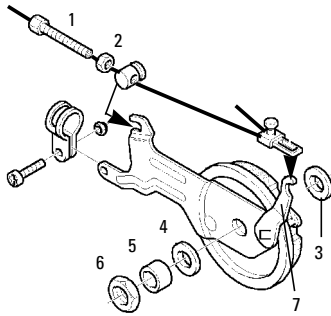

TYP H 7225 (DRUM BRAKE)

Instal brake anchor plate (or exchange it) Fig. 18

- Place thrust washer (3) over the axle on the adjusting cone and fit complete brake anchor plate. Position washer (4) distance sleeve (5) and screw on locknut (6). Push brake lever (7) to the stop and hold it there to center the brake jaws in the brake drum – tighten up locknut with a torque of 15...20 Nm.

Brake adjustment (Fig. 18)

- Unscrew adjusting screw (1) until the brake lightly touches the wheel when it is turned.
- Operate the hand brake lever **several times** forcefully and then turn the adjusting screw further as necessary until the brake lightly touches the wheel again.
- Lock the hex nut (2)
- Repeat adjustment operation if the braking effect is reduced after lengthy use or if the hand brake lever can be pulled back to the handlebar grip.

MAINTENANCE / SERVICING

- The Spectro S7 is provided with permanent lubrication and under normal conditions is maintenance-free. If the brake is loaded excessively its effect can be too strong. In such a case the brake shell should be lubricated with a special grease. Keep the pawl pockets free from grease. (Art. no. 0369 135 100)

After completely dismantling the hub the following items should also be noted:

1. Cleaning of parts:

- All parts – except for the planetary gear carrier – can be degreased in a cleaning bath.
- The planetary gear carrier only needs to be cleaned on the outside with a brush so as not to degrease the planetary gear bearing.

2. Lubrication of parts:

- To lubricate the bearing points on the planetary gear sets, position the planetary gear carrier on its crown and apply 2–3 drops of oil to the bearing bolts – at the same time turning the planetary gears so that the bearing points are completely wet. Oil axle through the axle bore and axle slot, apply a thin coating of grease to the outside.
- Oil the inside of the sun gears, grease the outside teeth (fill the gaps in the teeth).
- Oil outside teeth and carrier plate on the coupling gear and lightly grease the borehole from right and left.
- Do not apply grease to ring gear but just oil the pawl pockets.
- Grease the brake cone in the borehole and the friction spring.
- Spread grease on the inside and outside of the brake shell.
- Regrease ball retainer, line ball bearing running tracks with grease.
- Fill lever cone with grease reserves for brakes

Advice:

- If the cycle is not used for a long period put the shifter into gear position "1" to reduce the strain on the system.**
- Hub gears should not be subjected to high-pressure water during cleaning (e.g. strong water jet, high-pressure cleaner etc.) – any water which penetrates could lead to functional problems.**

TROUBLE SHOOTING

Problem	Likely cause	Corrective action
Pedals are carried forward when freewheeling	<ul style="list-style-type: none"> Bearings adjusted too tightly Loose locknuts Chain tension too tight 	<ul style="list-style-type: none"> Re-adjust bearings Tighten locknuts (15–20 Nm) Reduce chain tension
Pedals slowly give when braking – only type 7215 (does not impair safety)	<ul style="list-style-type: none"> Brake cone/brake shell 	<ul style="list-style-type: none"> Exchange brake cone and brake shell
Hub locks during braking • only type 7215	<ul style="list-style-type: none"> Brake shell run dry 	<ul style="list-style-type: none"> Wash hub shell clean, emery the brake cylinder surface, lubricate (see "Maintenance/servicing"), exchange brake shell

SPECTRO P5

1

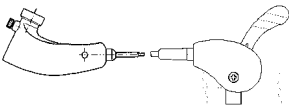

Type H 5215 with coaster brake
Type H 5205 without brake
Type H 5225 with drum brake

TECHNICAL DATA / ASSEMBLY REQUIREMENTS

Advice:

Type H 5205 is authorized for use in tandem.

Hub:

Total ratio: 251 %

Ratio:

Gear	Ratio
1.	1 : 0.63
2.	1 : 0.78
3.	1 : 1
4.	1 : 1.28
5.	1 : 1.58

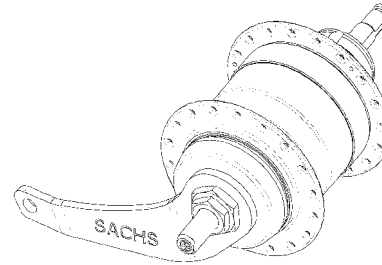

Ratio specifications:

- Primary 1.8...1.9 for 26" + 28"
- Example:
Front chainwheel T = 44
Rear chain sprocket T = 24

2

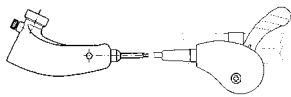

3



Spoke length table:

Type	Cross	L	Tire Size	
H 5215/...05	3 x	181 mm	47-406	
H 5225	3 x	179 mm	20" x 1.75 x 2	
H 5215/...05	3 x	225 mm	37-490	
H 5225	3 x	222 mm	22" x 1 3/8	
H 5215/...05	3 x	232 mm	47-507	
H 5225	3 x	229 mm	24" x 1.75 x 2	
H 5215/...05	3 x	251 mm	37-540	
H 5225	3 x	248 mm	24" x 1 3/8	
H 5215/...05	3 x	259 mm	47-559	
H 5225	3 x	256 mm	26" x 1.75 x 2	
H 5215/...05	3 x	275 mm	37-590	
H 5225	3 x	272 mm	26" x 1 3/8	
H 5215/...05	3 x	289 mm	47-622	37-622
H 5225	3 x	286 mm	28" x 1.75	28" x 1 3/8 x 1 5/8
H 5215/...05	3 x	289 mm	28-622	32-622
H 5225	3 x	286 mm	28" x 1 1/8	28" x 1 5/8 x 1 1/4
H 5215/...05	3 x	294 mm	28-630	32-630
H 5225	3 x	291 mm	27" x 1 1/4 fifty	27" x 1 1/4

4

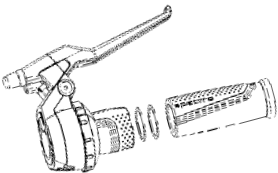

5

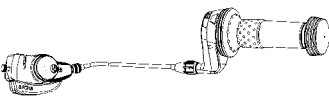

Shifter:

Standard shifting system consists of:

- Thumb shifter, 2 versions designed for in front of/behind handlebars
- Push-pull-cable
- Clickbox
- Ø Cable housing, 4.2 mm
- Ø Clips, 22...23.5 mm, tightening torque of fixing screws 2.5...3.0 Nm
- Thumb shifter (for push-pull clickbox), in front of handlebars version (Fig. 1)
- Thumb shifter (for push-pull clickbox), behind handlebars version (Fig. 2)
- Spectro Grip 5 rotational shifter, with Mini Clickbox for adults (Fig. 3)
- Spectro Combi 5 rotational shifter with integrated brake lever and Mini Clickbox for adults (Fig. 4)
- Bandix 5 rotational shifter, for children/young people (from 24" wheel size), (Fig. 5)

Cycle frame:

- The strength must be such that with a max. torque of 250 Nm on the driving wheel no residual deformation can occur on the rear structure.
- When installing the cable avoid small radii – route via bottom bracket, tube clips of 28 mm dia. for standard frame, Fig. 6 (1)
- Last attachment point is on lower rear fork immediately behind the chainwheel, tube clips of 20 mm dia. for standard frame, Fig. 6 (2)

Chain:

Permitted chains 1/2" x 1/8" e.g. Power Chain PC1 or 1/2" x 3/32".

6

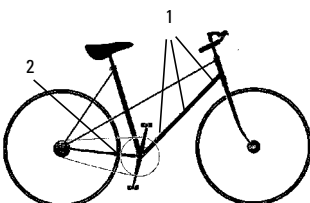

SPECTRO P5

ASSEMBLY DATA

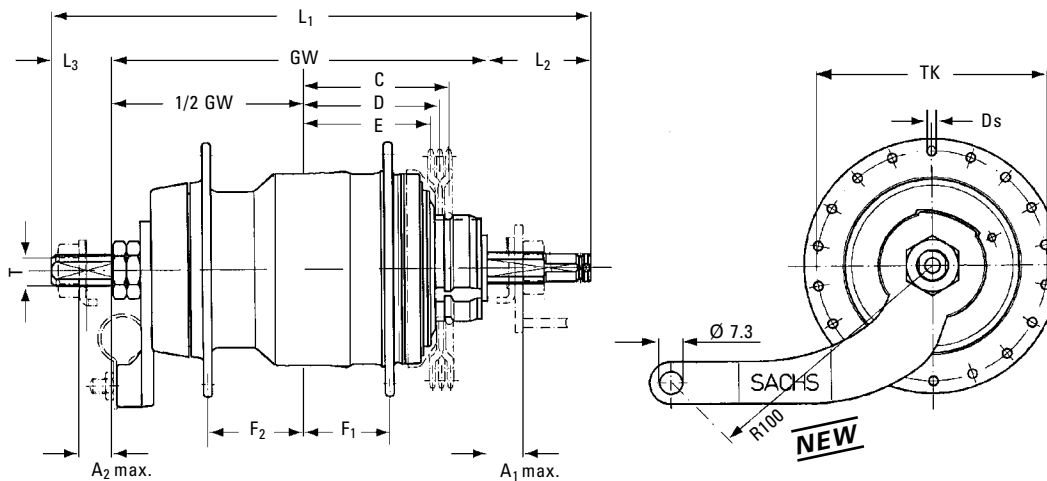

		MH 5215	MH 5205	MH 5225
Coaster brake		X		
Freewheel			X	
Drum brake				X
Fork width	GW	122	123	126
Axle length	L ₁	175	175	179
Axle right	L ₂	33.5	33.5	32.5
Axle left	L ₃	19.5	18.5	20.5
Axle end 2-flat	8.6	8.6	8.6	8.6
Axle thread	T	FG 10.5	FG 10.5	FG 10.5
Max. Dropout width dimensions	A _{1 max}	11.5	11.5	11.5
Max. Dropout width dimensions	A _{2 max}	11.5	10.5	12.5
Smallest sprocket (offset)	Pos. C	16	16	16
Smallest sprocket (straight)	Pos. D	17	17	17
Smallest sprocket (offset)	Pos. E	18	18	18
Chain line (offset)	Pos. C	49	49.5	51.5
Chain line (straight)	Pos. D	45.5	46	48.5
Chain line (offset)	Pos. E	43	43.5	45.5
Chain ratio		1.8...1.9 for 26" and 28"		
Spoke hole	• Number	36	36	36
	• Diameter	Ds	3.0	2.8
	• Circle diameter	TK	75	90
Spoke flange distance to 1/2 GW	F ₁	28.5	29.0	30.5
Spoke flange distance to 1/2 GW	F ₂	29.5	29.0	29.5
Torque on axle nut		30...40 Nm	30...40 Nm	30...40 Nm
Torque on on brake lever clamp		2...3 Nm		2...3 Nm

Dimensions in mm

SPECTRO P5

7

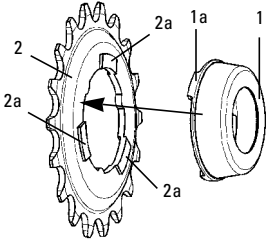

ASSEMBLY

- For insertion see spoke length table under "Technical data"

Fit dust cap (optional, Fig. 7)

- Turn dust cap (1) so that the lugs (1a) are located between the three ridges (2a) on the sprocket (2).

Fitting the wheel

- Put dust cap (1) in place and push towards the sprocket (2) until engagement is felt.
- Fit wheel in rear fork, fit non-turn washers (3, Fig. 8) on both sides. The serrations must bear against the outside of the dropouts and the prongs must engage in the dropout slots.

Advice:

If a chain tensioner is provided fit the non-turn washers (3) so that the serrations bear against the inside of the dropouts. The fixed cone (drive side) must always directly bear against the dropouts.

- Fit protective bracket (4, Fig. 9) directly below the axle nut on the sprocket side.
- Tightening torque of axle nuts, approx. 35 Nm.
- Fit brake lever clamps (5, Fig. 8)
- Tightening torque: 2–3 Nm.

Caution:

The clamps must be seated on the frame so that there is no play.

Thumb Shifter/Clickbox (Standard version):

- Fit shift rod (5, Fig. 10) on shift tube (6) (lightly oil all parts) and push into axle bore to the stop. Apply slight pressure on the shift rod with its threaded section and screw inwards in a clockwise direction until it can again be moved axially.
- Push Clickbox onto the hub axle as far as

the stop. Then make sure that the knurled bolt engages the slot on the hub axle when tightened up. It is not necessary to adjust the shifter.

Mini Clickbox (see Fig. 11):

- Assembly of shift rod (8, without head) and shift tube (9, with slot) is the same as the standard version.
- First push the adjuster barrel (13) with guiding rib (12) onto the hub axle – making sure that the lug (10) is guided into the slot on the shift tube (11) – until it can be felt to engage. Turn guiding rib (12) to face upwards.
- Push Clickbox to the stop on the hub axle. The guiding rib (12) should then be fully seated in the slot on the Clickbox housing.

For both versions the following applies:

- After fitting the Clickbox tighten up the knurled bolt by hand making sure that the knurled bolt engages with the slot in the hub axle. Assembly can be carried out independently of the shifter setting but it is easiest to assemble the Clickbox in 2nd gear (without the need to overcome spring pressure).

Advice:

Shifter adjustment or retroadjustments are only necessary with the Mini Clickbox. Carry out adjustment work or check settings after changing a wheel (e.g. after a flat tire).

Removal of rear wheel:

- Loosen knurled bolts
- Withdraw clickbox, the shift rod/tube can be left in the hub axle without being lost. To remove both parts pull shift rod outwards and unscrew in an counter-clockwise direction.
- Remove wheel as normal.

8

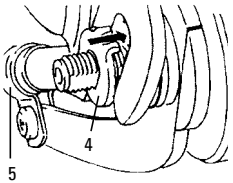

9

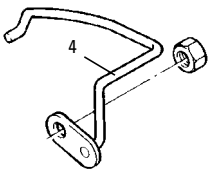

10

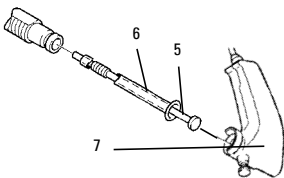

11

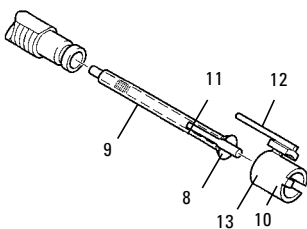

Differences between the push-pull clickbox and the Mini Clickbox (see also Figs. 10 and 11)

	Thumb Shifter/Clickbox/Push Pull	Rotational shifter/Mini Clickbox
Shift tube	Gray, without slot	Silver color, with slot
Shift rod	Dark gray, with head and a thread 121.5 mm lg	Copper colored, without head, with two threads 113.8 mm lg.
Locating sleeve	None	Included
Shifter adjustment	No	Yes, see "Shifter adjustment"

13

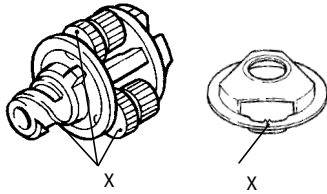
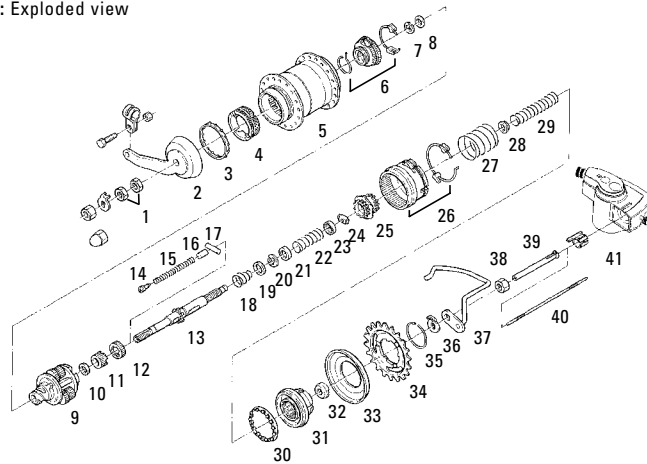

Figure 12: Exploded view



DISMANTLING THE HUB ASSEMBLY OF HUB

(see exploded view, Fig. 12)

- Remove circlip (35), sprocket (34) and dust cap (33).
- Clamp hub with sprocket side facing downwards with the two axle flats.
- Unscrew the two locknuts (1).
- Remove lever cone (2), ball retainer (3) and brake shell (4).
- Withdraw hub sleeve upwards.
- Unscrew brake cone (6) from flat thread.
- Remove retaining washer (7), thrust washer (8).
- Remove planetary gear carrier (9) and thrust washer (10).
- After this clamp hub in a vise.
- Unscrew fixed cone (32).
- Remove driver (31), compression spring (29), large compression spring (27) and ball retainer (30). – Withdraw ring gear (26) and coupling gear (25) and then remove conical cap (23) from the coupling gear.
- Take out thrust block (24), (to do this press the spring together). Remove spring (22) and the two conical caps (23/21).
- Dismantle retaining washer (20), washer (19), conical compression spring (18), and the large sun gear (12). Reclamp axle, (thrust block visible).
- Unscrew grub screw (14)
- **(Caution: It is subject to spring pressure)** – Dismantle spring (15), guide bolt (16) and thrust block (17).
- Remove small sun gear (11).

Hub types H 5205/H 5225 should be dismantled in the same way. Difference: Instead of the brake shell/-cone, a click-and-pawl carrier is mounted on the planetary gear carrier here. For cleaning and lubrication see "Maintenance/servicing".

(see exploded view, Fig. 12)

- Clamp axle with internal thread upwards.
- Position small sun gear (11) with crown gears to the front.
- Position thrust block (17) in the slotted hole (is laterally guided when the sun gear is screwed in).
- Locate bolt (16), then spring (15) in the axle and screw in grub screw (14) until it is flush with the axle.
- Reclamp axle. Fit large sun gear (12) (it is the same both sides). Position conical compression spring (18), with the large diameter first. Press spring together and fit washer (19) and retaining washer (20).
- Assemble conical cap *) (21), compression spring with 7 turns (22) and the second conical cap *) (23).
- Press spring together and position thrust block (24) (it is the same both sides) in the center of the slotted hole.
- Position coupling gear (25) with carrier plate facing downwards.
- Fit conical cap *) (28) for compression spring.
- Position ring gear (26) over the teeth of the coupling gear.
- Place ball retainer (30), with balls below on the ring gear.
- Position large compression spring (27) on ring gear.
- Mount compression spring with 13 turns (29) on the axle. (Is supported in the coupling wheel by the conical cap).
- Locate driver (31), press it down and screw on fixed cone (32) as far as the stop. Tightening torque 20 Nm. (Then reclamp hub in vise).
- Push on thrust washer (10) and fit planetary gear carrier (9). In doing this: Position mounting aid (Fig. 13) on the planetary gear carrier so that the (X) markings on the threeplanetary gears match with the mounting aid.

SPECTRO P5

14

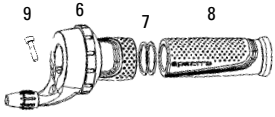

- Insert planetary gear carrier, place thrust washer (8) on it and mount retaining washer (7) in recess.
Only now should you remove the mounting aid.

Advice:
If the gears are not accurately installed the hub may be tight to move.
This could lead to damage to the gearwheels in operation. For lubrication of the hub see "Maintenance/servicing".

15

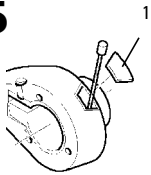

- Screw brake cone (8) onto flat threads.
- Mount hub sleeve (5), with a slight counter-clockwise turn over the pawl.
- Locate brake shell (4) – with retaining lugs uppermost –, then the friction spring on the brake cone must engage with the slot on the brake shell.
- Insert ball retainer (3) – with balls below.
- Position lever cone (2) – in doing this turn it clockwise until the retaining lugs engage.
- Screw on counternuts (1), adjust bearings to be free of play and tighten lock nuts. Tightening torque 15–20 Nm.

The assembly of hub types H 5205/H 5225 should be carried out in the same way. Difference: Instead of the brake shell /-cone a click-and-pawl carrier is installed here on the planetary gear carrier. Without flat threads – fixed with a retaining washer.

16

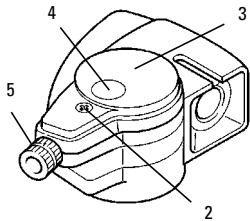

ASSEMBLY OF ROTATIONAL SHIFTER / EXCHANGE OF CONTROL CABLES / ADJUSTMENT OF SHIFTER

(Mini Clickbox)

Assemble rotational shifter (Fig. 14):

- Push shifter (6) onto handlebars
- Push on two thrust washers (7)
- Mount fixed grip (8) onto ends
- Place shifter (6) against fixed grip (8).
- Align shifter (6) on handlebars and tighten up using bolt (9).
Tightening torque 1.5 Nm

Advice:
Do not fit fixed grips (8) on both the right and left of the handlebars with greasy materials.

Dismantling the shifter cable:

- (Valid for Spectro Grip 5/Bandix 5/ Spectro Combi 5)
- Lever off cap (1, Fig. 15) from shifter housing.
 - Set rotational shifter to 1st gear. (Cable head on the control cable must be visible in the opening).
 - Unscrew bolt (2, Fig. 16), remove cap (3).
 - Withdraw shifter cable and clamping bolt (6) upwards, loosen clamp and pull clamp from cable. (Fig. 18)

Assembly of shifter cable:

- In gear position "1" insert shifter cable through sight window (Fig. 1) – pull shifter cable out through opening in shifter.

Caution:
Only use shifter cables with dia. of 1.35 mm article no. 0391 007 004

- Screw in adjusting screw on the rotational shifter completely.
- Position clamping bolt (6) at a spacing of 68.5 mm, tighten up with a torque of 1.5 Nm and cut off cable ends to 2...3 mm. (see Fig. 17)
- Fig. 18: Insert clamping bolt (6) and place shifter cable around the carrier cylinder (counter-clockwise winding direction).
- Insert the square nut of the adjusting screw (5) in the housing and screw in the knurled bolt completely.

Adjustment:

- Be sure to reset rotational shifter from 4th to 3rd gear
- Position cap (3) and tighten up with bolt (2).
- Make sure that the cap on the twistgrip (1, Fig. 1) engages in the shifter housing.
- Match up the arrow marks in the viewing window (4) of the cap (3) by turning the adjusting screw (5).
From time to time check the setting and readjust as necessary.

Advice:
To set the clamping bolt – adjusting screw distance, a setting piece can be used.
Order no. 0324 105 000

TYP H 5225 (DRUM BRAKE)

Instal brake anchor plate (or exchange it) Fig. 19:

- Place thrust washer (3) over the axle on the adjusting cone and fit the complete brake anchor plate. Position washer (4) and distance sleeve (5) and screw on the locknut (6). Push brake lever (7) as far as the stop and hold it tight to center the brake jaws in the brake drum – tighten up the locknut with a tightening torque of 15...20 Nm.

Brake adjustment (Fig. 19):

- Unscrew adjusting screw (1) until the brake lightly touches the wheel when turning.
- Forcefully operate the hand brake lever several times and then turn the adjusting screw further as necessary until the brake begins to touch the wheel again.
- Lock the hex nut (2).
- Repeat adjustment operation if after lengthy use the braking effect is reduced or the hand brake lever can be pulled back to the handlebar grip.

17

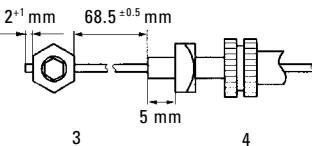

18

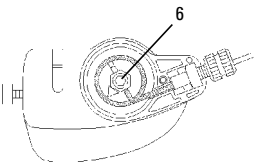

19

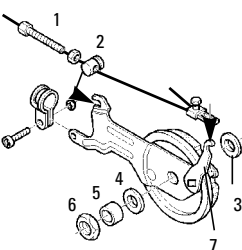

SPECTRO P5

MAINTENANCE / SERVICING

- The Spectro P5 is provide with permanent lubrication and under normal conditions is maintenance-free. If the coaster brake is loaded excessively its effect can be too strong. In such a case the brake shell should be lubricated with a special grease (art. no. 0369 135 100).

After dismantling the hub the following items should be carried out:

- Oil axle through the axle bore and lightly grease the outside.
- Lightly grease the inside teeth on the ring gear – but only oil the pawl pockets.
- Oil coupling gear and carrier plate assembly on both sides, do **not** grease.

- Only clean the planetary gear carrier with a brush (**do not put in cleaning bath**)
- To lubricate the bearing points on the planetary gear sets position the planetary gear carrier on its crown and apply 2–3 drops of oil to the bearing bolts – while doing this turn the planetary gears so that the bearing points are completely wetted. Grease bearing points etc. as normal and provide lever cone with a grease supply.

Advice:

- ***If the cycle is not used for a lengthy period, set shifting lever to gear position "2" so that the system is not strained.***
- ***Do not use high-pressure water when cleaning the hub gear unit (e.g. strong water jets, high-pressure cleaners etc.) – if water penetrates the unit it could lead to functional problems.***

TROUBLE SHOOTING

Problem	Cause	Corrective action
Difficulty in shifting Pedals rotate forwards when freewheeling	<ul style="list-style-type: none"> • Damaged control cable • Bearing set too tight • Loose locknuts • Chain tension set too high 	<ul style="list-style-type: none"> • Replace control cable • Reset bearing • Tighten locknuts (15–20 Nm) • Reduce chain tension
Pedals slowly give when braking – only type H 5215 (this does not impair safety)	<ul style="list-style-type: none"> • Brake cone/brake shell 	<ul style="list-style-type: none"> • Exchange brake cone and brake shell
Hub locks when braking – only type H 5215	<ul style="list-style-type: none"> • Brake shell has run dry 	<ul style="list-style-type: none"> • Wash out hub sleeve, repolish and relubricate brake cylinder, renew brake shell

SPECTRO T3

1

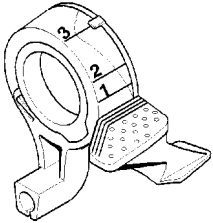

SPECIFICATIONS

Type H 3115 with coaster brake
 Type H 3105 without brake
 Type H 3125 with drum brake

The ideal drive for city and recreational bikes – simple to operate and adjust with precise gear selection using a variety of shifters. The **Spectro T3**-hub is practically maintenance-free.

TECHNICAL DATA

Advice:
 The hub is not suitable for tandem use.

Technical data:

Total ratio:	186%
1st gear (hill gear)	Ratio 1 : 0.73 (- 27%)
2nd gear (normal gear)	Ratio 1 : 1
3rd gear (fast gear)	Ratio 1 : 1.36 (+ 36%)

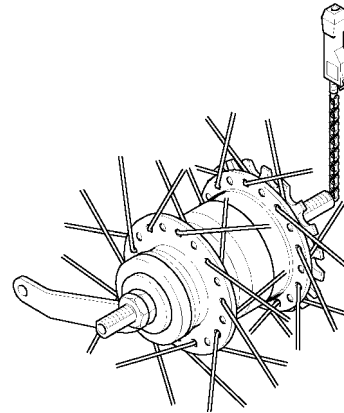

2

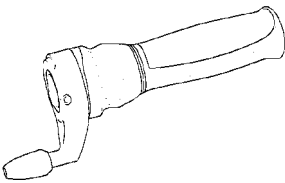

Distance travelled by one pedal revolution (example):

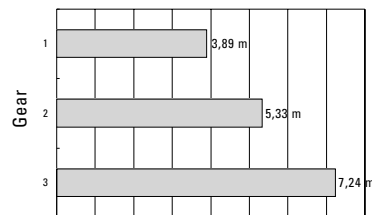

Handlebar shifter:

- Spectro Click 3 (**Fig. 1**)
- Handlebar diameter 22.0...22.4 mm
- Fixed grip diameter in shifter area max. 33 mm
- Select a brake lever that allows the shifter to function correctly

Caution:

This shifter uses a derailleur cable with a Ø 3 mm head and 3 mm length.

Rotational shifter:

- Spectro Grip 3 (**Fig. 2**) with left dummy grip
- Handlebar diameter 22.0...22.4 mm
- Length of the straight required handlebar end min. 145 mm + width of the brake lever clamp

3

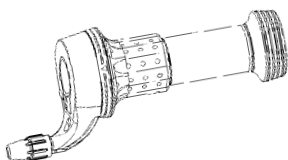

Rotational shifter:

- Bandix 3 for kids (**Fig. 3**)
- Handlebar diameter 22.0...22.4 mm
- Length of the straight required handlebar end min. 125 mm + width of the brake lever clamp

SPECTRO T3

ASSEMBLY DATA

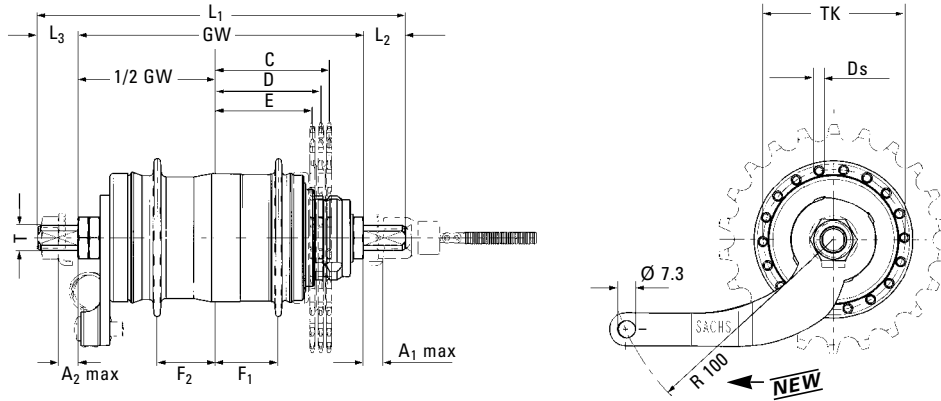

Primary ratio:

(Number of teeth on chainring divided by number of teeth on sprocket = primary ratio)

26" wheels 2.0...2.4

28" wheels 2.0...2.4

Bike frame:

- For brake hubs, the rear frame must be designed so that there is no lasting deformation of the chainstay at a wheel torque of 250 Nm (184 ft.lbs.).

Chain:

- Roller chain 1/2" x 1/8" oder 1/2" x 3/32" (depending on the thickness of the sprocket used).

3 speed hubs		MH 3115	MH 3105	MH 3125
Coaster brake		X		
w/o brake			X	
Drum brake for disc brakes				X
Over locknut dim.	GW	118	117	118
Axle length	L ₁	152/164	152/164	164
Axle right	L ₂	17.7/22.2	17.7/22.2	22
Axle left	L ₃	16.3/23.8	17.3/24.8	24
Axle end 2-flat		8.6	8.6	8.6
Axle thread	T	FG 10.5	FG 10.5	FG 10.5
Max. dropout width dimensions	A _{1 max}	9.7/14.2	9.7/14.3	14
Max. dropout width dimensions	A _{2 max}	8.3/15.8	9.5/14.0	16
Smallest sprocket (off-set)	Pos. C	16	16	16
Smallest sprocket (straight)	Pos. D	16	16	16
Smallest sprocket (off-set)	Pos. E	16	16	16
Chain line (off-set)	Pos. C	44.5	44	44.5
Chain line (straight)	Pos. D	41.5	41	41.5
Chain line (off-set)	Pos. E	38.5	38	38.5
Chain ratio		2.0...2.4 for 26" + 28"		
Spoke hole – Number		28/36	36	36
– Diameter	D _s	3.0	3.0	2.8
– Circle diameter	TK	58	58	89
Spoke flange distance to 1/2 GW	F ₁	24.5	24.5	25.5
Spoke flange distance to 1/2 GW	F ₂	25.5	25.5	32.5
Torque on axle nut		30...40 Nm	30...40 Nm	30...40 Nm
Torque on Brake lever frame clamp		2...3 Nm		2...3 Nm

Dimensions in mm

SPECTRO T3

4

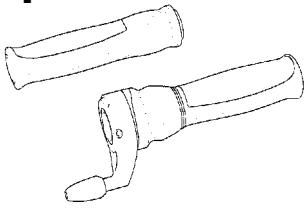

SYSTEM COMPONENTS / ACCESSORIES

Three speed hub with accessories (see also assembly data)

- Spectro Grip 3 with left dummy gripi (Fig. 4)
- Bandix 3 with left dummy grip (Fig. 5)
- Spectro Click 3 (1, Fig. 6)
- Shifting cable (2) for Spectro Click 3 (cable head Ø 3 mm/length 3 mm) and shifting cable push pull for Spectro Click 3 Ø 6 mm (Fig. 6)
- Locating sleeve (3) and locating sleeve with clamping device (3a, Fig. 6)
- Cable stop clamp with retaining strap (4, Fig. 6)
- Cable pulley clamp with retaining strap (5, Fig. 6)
- Brake lever clamp (6, Fig. 7)
- Bike clip with retaining strap or direct assembly (Fig. 8)
- Chain 1/2" x 1/8" 1/2" x 3/32"

5

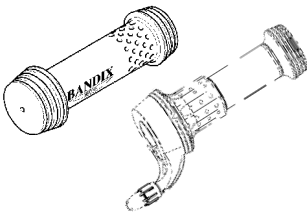

6

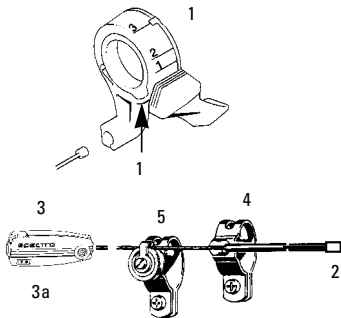

ASSEMBLY

- Spoke the hub as normal.
- Place the dust cap and sprocket on the driver.
- Push sprocket circlip 4 onto the cone of tool sleeve 5. Place tool sleeve 5 with large diameter on the driver.
- Push the spring end of sliding sleeve 6 of the tool over the tool sleeve. Thrust sliding sleeve 6 in direction y, this forces circlip 4 into the recess of the driver (Fig. 9) – Remove tool 5/6 and check that the circlip is seated correctly.
- Turn dust cap (1, Fig. 11) until the three lugs (1a) are between the three beads (2a) on the sprocket (2).
- Position dust cap (1) and push towards sprocket (2) until it is felt to lock into place. (Fig. 11)
- Placing the wheel in the rear frame
- Fit the chain
- Guide the axle ends into the slot of the dropouts
- Fit retaining washers (1) on the two ends. The teeth must face outwards at the dropout, the prongs must catch in the dropout (Fig. 10). Tighten the axle and chain guide nut, 15 mm wrench, tightening torque 30...40 Nm (22–29 ft.lbs).
- Screw tight the corresponding brake lever clamp (2) (Fig. 10) 10 mm wrench, screwdriver, tightening torque 2...3 Nm (1.5–2.2 ft.lbs).

7

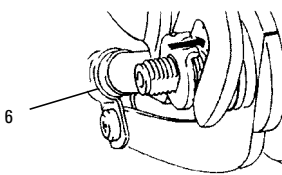

8

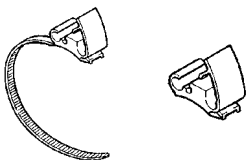

- Align the shifter on the handlebar and tighten screw (1, Fig. 12). Allen key 2.5 mm, tightening torque 2 Nm (1.5 ft.lbs).
- Align the brake lever on the handlebar and secure.
- Check that the shifter and brake lever function properly and are unobstructed (realign if necessary).

Mounting/changing the shift cable:

(if necessary push the brake lever and shifter out of the way and replace and secure after the cable has been changed)

- Guide the cable head (Ø 3 mm) of the shifting cable into the side opening (diagram A), push through shifter body the cable head (diagram B).
- Insert the shifter cable in the groove and place the end of the cable housing in the recess (diagram C).

Caution:

The exact shifting function is only guaranteed with the pus-pull cable housing.

Mounting the Bandix 3:

- Push shifter onto the handlebar (Fig. 13)
- Push on two washers.
- Mount the fixed grip up to the end.
- Push the shifter up against the fixed grip. Align the shifter on the handle-bar and secure in place using screw.
- Allen key 3 mm, tightening torque 1.5 Nm (1 ft.lbs).

Advice:

Do not use grease solutions to mount the left and right fixed grips (2) on the handlebar.

- Screw the cable stop clamp and cable pulley clamp on the down tube or seat tube (Fig. 14).
- Secure the lubricated shift cable at equidistant intervals on the frame (continuous cable housing).
- For a locating sleeve with clamping bolt (Fig. 15, No. 3): feed the control cable into the locating sleeve, fix at the appropriate length using the clamping bolt. Shorten any cable which is sticking out. (Allan key 2.5 mm) Tightening torque 0.8–1 Nm (7–8.8 in.lbs).
- Connect the shift cable to the hub: Push locating sleeve (3) onto small pull rod (9) (Fig. 15), shifter position gear "3".

Mounting the Spectro Grip 3 (see Fig. 13):

Caution:

Not recommended for use on thin walled aluminium handlebar such as Hyperlite® type handlebar.

- Slide the shifter onto the right side of the handlebar.
- If necessary, move the brake lever to allow for the shifter and the handlebar grip.
- Bar end users – don't forget to leave room for the bar end.

9

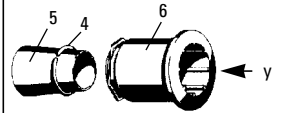

10

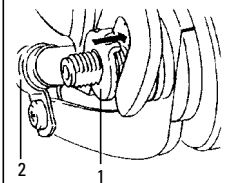

11

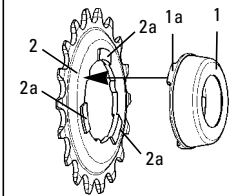

12

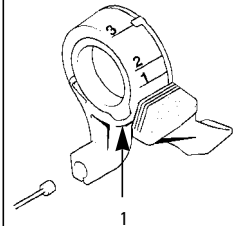

A

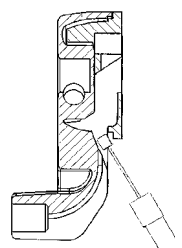

SPECTRO T3

B

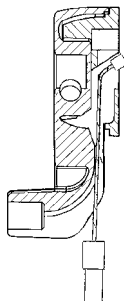

C

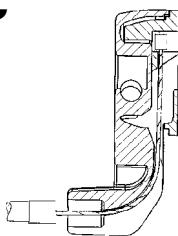

- Rotate the shifter until the barrel adjuster is beneath (but out of the way of) the brake lever.
- Tighten the 2.5 mm hex clamp bolt to 1.7 Nm. (15 in-lb).
- Slide the plastic washer onto the **right** side of the handlebar.
- The washer prevents the handlebar grip from interfering with the shifter rotation.
- Slide the short handlebar grip onto the **right** side of the handlebar.
- Slide the long handlebar grip onto the **left** side of the handlebar.
- **Solvents, lubricants or hair spray may damage the handlebar grips!**
- Use **only** compressed air or water to aid installation.
- Feed the cable through the cable housing and stops.
- For a locating sleeve with clamping bolt (**Fig. 15, No. 3**): feed the control cable into the locating sleeve, fix at the appropriate length using the clamping bolt. Shorten any cable which is sticking out.
- (Allan key 2.5 mm) Tightening torque 80–100 Ncm (7–8.8 in.lbs).
- Connect the shift cable to the hub: Push locating sleeve (3) onto small pull rod (9) (**Fig. 15**), shifter position gear "3".

Shift adjustment:

- Place the shifter in gear position "3". Move the crank to check that the gear is engaged.
- To make the adjustment, the cable must be taut in third gear to be able to transfer a shift movement directly to the hub.
- Push locating sleeve (3) onto the small pull rod (9) until the control cable is taut. Make sure that you don't pull the indicator chain out of the chain guide nut (**Fig. 15**).

To check:

- Place shifter in gear position "1" while moving the crank.
- Setting too loose: In gear position "1" the indicator chain can be pulled out of the chain guide nut by hand.
- Setting too tight: It is difficult to place the shift lever in gear position "1".
- If required, readjust the shift mechanism (in third gear).

13

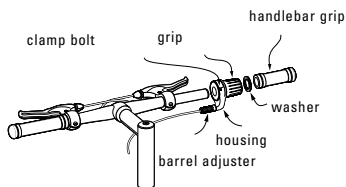

Spoke length table

Type	No. of holes	Crossover	Tire designation			
			47–406	37–490	47–507	37–540
			20" x 1.75 x 2	22" x 1 3/8	24" x 1.75 x 2	24" x 1 3/8
H3115/05	28	2x	182 mm		234 mm	
	36	3x	184 mm	228 mm	235 mm	254 mm

14

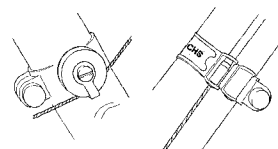

Type	No. of holes	Crossover	Tire designation				
			47–559 26" x 1.75 x 2	37–590 26" x 1 3/8	47–622 28" x 1.75	25–622 28–622 32–622 37–622 28" x 1 1/4 28" x 1 5/8	28–630 32–630 27" x 1 1/4
H 3115/05	28	2x	258 mm		289 mm		
	36	3x	262 mm	278 mm	292 mm	292 mm	297 mm
H 3125	36	3x	253 mm	273 mm	285 mm	285 mm	287 mm

15

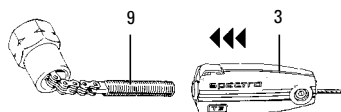

SPECTRO T3

16

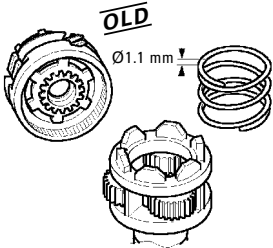

DISMANTLING AND ASSEMBLING THE HUBS

Disassembly (see exploded view):

- Unscrew indicator chain (23) (right-hand thread), remove circlip (21), sprocket (20), dust cap (19) and hub axle (10) on the driver side.
- Unlock hexagonal nuts (1) and unscrew.
- Remove brake arm (2), ball retainer (3) and brake sleeve (4) and remove hub shell (5).
- Remove safety washer (7), thrust washer (8) and then the planet carrier complete with brake cone (6). Unscrew the brake cone from the planet carrier (9).
- Turn hub over.
- Loosen the lock nut (22) and fixed cone (18) and remove.
- Remove driver (17), spring cover (15), compression springs (14 and 13) and ball retainer (16).
- Push the sliding key (12) through the large bore in the coupling wheel of the ring gear (11) – the bore and thrust block must be aligned.
- Remove the ring gear (11) from the axle.

Differences for types H 3105 and H 3125: See exploded views.

- There is no brake sleeve (4) and brake cone (6).
- The planet carriers (a) have a cylindrical shaft instead of a flat thread, which houses a pawl carrier (b) held by a safety washer instead of the brake cone.
- Further differences: instead of a lever cone (2) for type H 3115, an adjusting cone (d) with dust cap (e) for type H 3105 and a small adjusting cone (D) and corresponding ball retainer (f) for type H 3125 are fitted.

Working on individual components/ lubricating the parts

Replace defective or worn parts, lubricate or oil new and cleaned parts as follows:

- The brake sleeve (4) must be replaced in case of wear, ie diamond pattern hardly recognizable. Lubricate the inside and outside of the brake sleeve – pack the ring shaped groove on the lever cone (2) with grease, grease the brake cone (6) in the bore and the friction springs.
- Grease the bearing points of axle (10), ball retainers (3, 16) and in the driver (17). Pack the ball tracks of the sleeve (5) with grease.
- Oil the bearing points of the planet wheels on carrier (9), grease the outer face of the teeth.
- Oil the driving plate on the coupling wheel in the ring gear (11) – grease the bore lightly

Caution:

Use special grease, order no. 0369 135 100 and standard bike oil.

Only oil – do not grease – the stop notches/ stop notch cases on ring gears (11), pawl carriers (b) and brake cone (6).

Assembly – See exploded view for fitting position and direction.

- Clamp the hub axle (10) with the slot for thrust block upwards, fit ring gear (11) and align the large bore in the coupling wheel with the slot. Position the radius of the sliding key (12) facing downwards and turn the coupling wheel slightly.
- Fit the compression springs (13 and 14) followed by the spring cover (15).
- Place ball retainer with balls in (16) on ring gear (11), mount driver (17), fit fixed cone and lock with hexagonal nut (22), tightening torque 15–20 Nm (11–14 ft.lbs).
- Turn hub over and slide on planet carrier (9) – thrust washer (X) must first be fitted for types 3105/3125. (For type 3115, this washer is already integrated in the planet carrier). Mount thrust washer (8) and place safety washer (7) in the recess of the axle.
- Screw brake cone (6, type 3111) onto the flat thread – for types 3105/3125 mount pawl carrier (b) and secure in place using safety washer (c).
- Fit hub shell (5) – turning it counter-clockwise slightly to get past the stop notches – until the shell runs cleanly onto the ball retainer.
- For type 3115, insert the brake sleeve (4) so that the spring end of the friction spring on the brake cone (6) sits in one of the two slots on the brake sleeve. Insert the ball retainer and fit the lever cone – move the lever cone lightly to and fro until the lugs on the brake lever catch in the grooves on the adjusting cone.
- Adjust the hub clearance by screwing on hexagonal nut (1) until the hub shell runs free of play but not under tension. Lock with a second nut to a tightening torque of 15...20 Nm (11–14 ft.lbs.).
- For type H 3105 insert ball retainer (3), mount adjusting cone (d) with dust cap (e) and hexagonal nuts (1). Adjust the hub clearance as for type H 3115.
- For type 3125, the ball retainer (f) and dust cap (pressed in) normally remain in the hub shell. The hub clearance is set with adjusting cone (D) as for type H 3115. For notes on fitting the brake carrier, please refer to mounting drum brake.

17

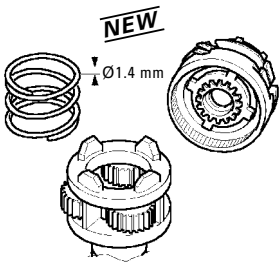

18

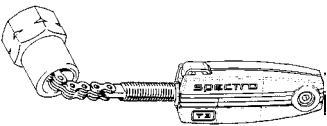

19

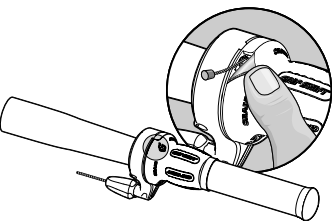

SPECTRO T3

MAINTENANCE / SERVICE / SAFETY

Type H 3115 with coaster brake:
improved braking in third gear after production date CW 38/96.

- In case of repair, older hub (Fig. 16) models can be converted with a repair set. It is important that all three parts are replaced at the same time – new, reinforced compression springs, planet carrier with 4 lugs and ring gear with 4 lugs on the driving plate, see Fig. 17.

A change with of the new or converted hubs: when braking in third gear, the tension chain moves out of the chain guide nut by approx. one chain link – after braking, the tension chain returns immediately to its normal position. (Fig. 18)

Advice:

The new brake sleeve, recognizable by the ribbed and grooved surface, improves braking values even further, see exploded view, type H 3115.

The Spectro hubs are equipped with permanent lubrication and are maintenance-free under normal conditions. For type H 3111, however, particularly high loading of the coaster brake can cause it to over-compensate. In this case, apply special grease to the brake sleeve. During transportation or longer periods when the bike is not used, shift the hub into third gear to relieve the system of load. Do not clean gear hubs using water under pressure (e.g. sharp water jet, high pressure cleaner etc.) – water in the system can cause it to malfunction.

Exchange of control cables/Rotational shifters (Spectro Grip 3/Bandix 3):

Spectro Grip 3 (Fig. 19):

- Leave the shifter on the handlebar.
- No need to move other components.
- The shifter does not need to be opened.**
- Use only new cable and compressionless cable housing
- Detach the cable from the internal hub.
- Remove the cable housing. Cut the cable off 6" from the shifter barrel adjuster. Discard the old cable and cable housing.
- Line up the '1' gear number mark with the indicator mark.
- Carefully peel back the corner of the grip cover shown in Figure 19. Use your fingernail or a small screw driver.
- Remove and discard the rest of the old cable.
- Feed the **new** cable through the cable entry in the grip and out through the barrel adjuster.
- Feed the cable through the **new** cable housing and stops.
- Connect the shift cable to the hub
- Push locating sleeve (3) onto small pull rod (9) (Fig. 15), shifter position gear "3".

Type H 3115 with coaster brake

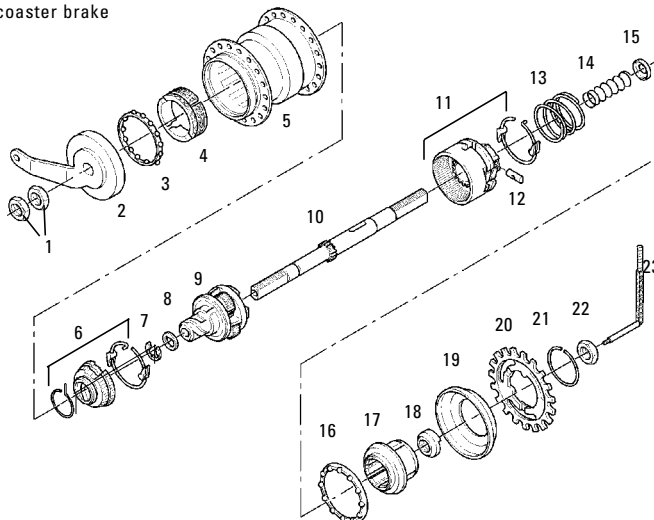

Type H 3105 without brake

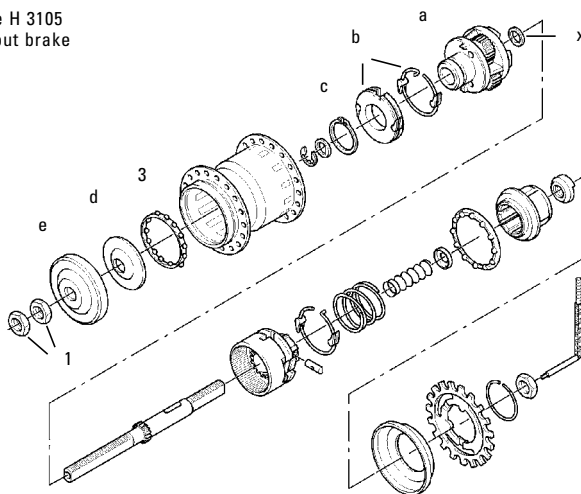

Type H 3125 with drum brake

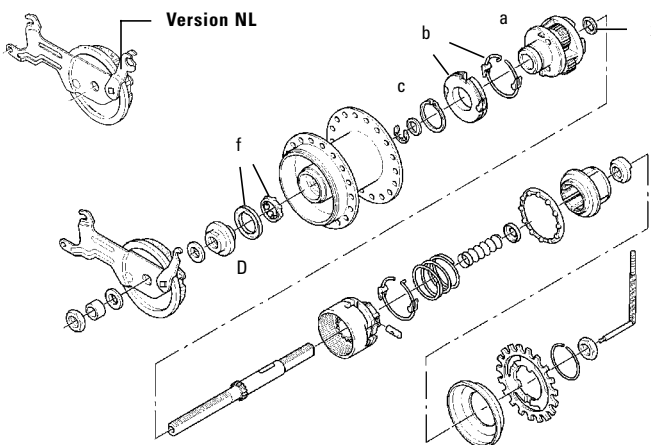

SPECTRO T3

20

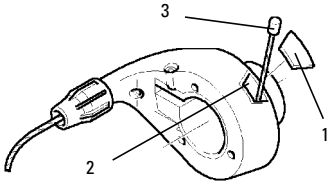

Bandix 3 (Fig. 20):

- Remove cover (1) from assembly window (2). Rotate the turning grip forwards up to the stop, until the cable head (3) can be seen in the assembly window. Push the cable out of the cable recess. Push in a new shift cable, position along the frame as required and pull into the cable recess on the shifter up to the stop.
- Connect the shift cable to the locating sleeve and close the assembly window. See shift adjustment.

21

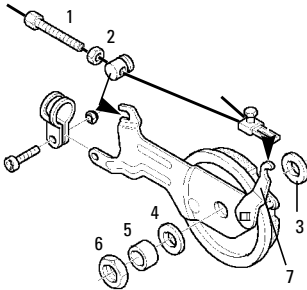

DRUM BRAKE

Fitting and changing the brake anchor plates (Fig. 21).

- Place thrust washer (3) over axle onto adjusting cone and insert the wheel assembly. Fit washer (4) and spacing sleeve (5) and screw on lock nut (6). Press brake lever up to the stop and hold in order to center the brake shoes in the brake drum. Tighten the lock nut with a tightening torque of 15...20 Nm (11–14.5 ft.lbs).

Adjusting the brake:

Unscrew the adjusting screw (1) until the brake pads drag lightly.

- Actuate the hand brake lever forcefully several times and then, if necessary, turn the adjusting screw further so that the brake once again brushes the wheel as it turns.
- Lock hexagonal nut (2).
- Repeat the adjustment procedure if the braking effect wears off after prolonged use or if the hand brake lever can be pulled back fully to the handlebar grip.

Caution:

Only use brake levers with a cable moving distance of at least 15 mm!

TROUBLESHOOTING CHECKLIST

No.	Fault	Cause	Remedy
1	3-speed hub (all types): Short jerk when starting or pedal crank making clicking noise (tension chain moves without gears being changed).	<ul style="list-style-type: none"> • Incorrect gear setting 	<ul style="list-style-type: none"> • Adjust the shifting system
2	Shifting difficulties	<ul style="list-style-type: none"> • Incorrect gear setting 	<ul style="list-style-type: none"> • Adjust shifting system, oil shifter and control cable, check that cable stop is seated correctly.
3	Pedals are drawn forwards in idle	<ul style="list-style-type: none"> • Bearings set too tight • Loose lock nuts • Chain is overtensioned 	<ul style="list-style-type: none"> • Adjust bearing • Tighten lock nuts • Loosen chain
4	Only 3-speed hub Typ H 3115: Pedals yield slowly during braking (does not impair safety)	<ul style="list-style-type: none"> • Brake cone/brake sleeve 	<ul style="list-style-type: none"> • Replace brake cone and brake sleeve
5	Hub locks during braking	<ul style="list-style-type: none"> • Brake sleeve has run dry 	<ul style="list-style-type: none"> • Wash out the hub shell, repolish brake cylinder, grease, replace brake sleeve

SPECTRO COMBI P5/S7 (INTEGRATED BRAKE SHIFTER)

1

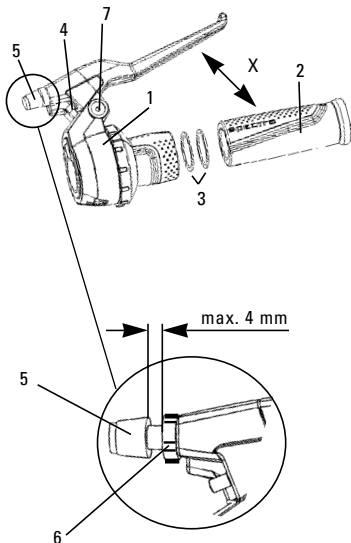

TECHNICAL DATA AND INSTALLATION REQUIREMENTS

Brake cable:

Ø 1.6 mm, with cable head with min. 5.8 mm,
Ø min 6 mm.
lever ratio: 3.7.

Pull cable path:

15 mm – making it especially suitable
for SRAM drum brakes

Handlebar:

Rated value – Ø 22.0...22.4 mm, length
of the straight cylindrical handlebar end
min. 158 mm

ASSEMBLY

- Push shifter (1) with rotating section on the handlebar.
- Push on 2 thrust washers (3).
- Mount fixed grip (2) on the end of the handlebar tube.
- Line up shifter (1) next to fixed grip (2).
- Align shifter (1) on the handlebar and tighten using a fastening bolt – 3 mm Allen screw, tightening torque 2.5 Nm (22 in.lbs).

Caution:

Do not mount fixed grips on the left- and right-hand side of the handlebar with grease or soap solutions – fixed grips could slip off the handlebar when the bicycle is being ridden. This could result in the rider falling and being injured.

- After all the components have been fitted, actuate the brake lever strongly several times and then check the brake setting. The instructions of the brake or component manufacturer must be followed.

Advice:

Using adjusting screw (4) (2 mm Allen screw), the grip width (X) of the hand lever can be individually adjusted ("reach adjust"). After carefully removing the polyglass sticker (7), any play in the hand lever can be adjusted using the Allen screw located beneath the sticker. The hand lever must continue to move freely, however. Replace the sticker.

Caution:

Do not unscrew the adjusting screw (5) for adjusting the brake by more than 4 mm (danger of breakage) – rather carry out the adjustment on the brake itself. Always counterlock the safety nut (6) against the lever housing.

SPECTROLUX V6

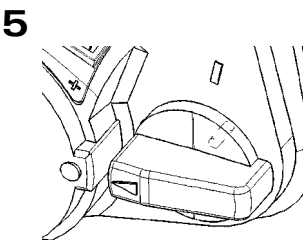
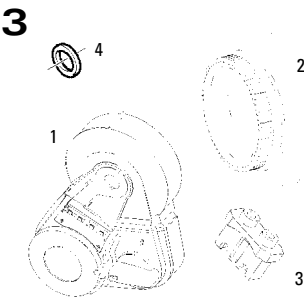
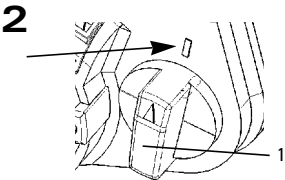
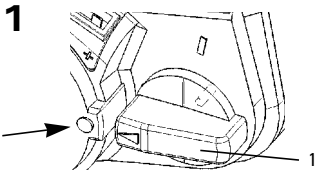

ADVANTAGES

Attractively designed dynamo which works perfectly in all weather conditions.

- Suitable for hubs P5 and S7, versions with coaster brake and without brake
- Extremely efficient, i.e. pedal resistance only increased very slightly
- Reliable power transmission, no slipping in wet weather or snow
- Quiet operation
- Cannot switch on accidentally
- Simple to operate
- Simple to install
- Simple to disconnect and connect electric plugs when changing the wheel
- Maintenance-free

OPERATION

- The dynamo is switched on and off at the control knob (*Fig. 1*)
- Arrow on the control knob pointing to symbol (A) on the housing = "OFF" position
- Arrow on the control knob pointing to symbol (B) on the housing = "ON" position. (*Fig. 2*)

TECHNICAL DATA

Type	Dynamo, driven by rear hub
Weight	230 g
Voltage	6 V
Output	3 W
Drive	via toothed adapter on rear hub, can be switched on and off

SYSTEM COMPONENTS

(*Fig. 3*)

- Dynamo (1) with dust cover
- Adapter (2)
- Cable plug x 2 (3)
- Washer (4) for hubs with coaster brake

INSTALLATION REQUIREMENTS

- For wheel sizes 24" and larger – suitable for all hub spiders
- 36 spokes
- Suitable for hub types:
 - P5 with coaster brake
 - P5 without brake
 - S7 with coaster brake
 - S7 without brake

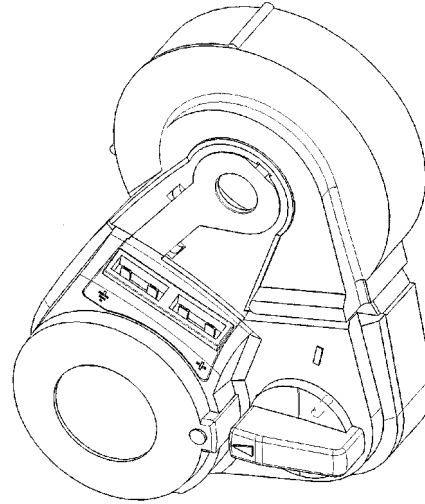

INITIAL ASSEMBLY

Installing dynamo

- Remove wheel as usual
- Snap on toothed adapter (1) with the 3 lugs (2) directly over the spoke flange, **not** over crossed spokes. (*see Fig. 4*)
- **Only for version with coaster brake:** fit a washer 1.5 mm thick (3, *Fig. 4*) to the axle between hub and dynamo.
- Fit dynamo making sure the control knob is in the "OFF" position. (*Fig. 5*)
- Fit wheel as usual, but only tighten axle nuts slightly.
- The position of the dynamo can be varied. However, it should not collide with frame or add-on parts or rest against the brake lever of the hub with coaster brake. We recommend a position in which the control knob is almost vertical in the "ON" position. (*see Fig. 6*)
- Tighten axle nuts to a torque of approx. 35 Nm. Make sure the wheel is aligned in the frame and that the chain is correctly tensioned.

Caution:

The axle projecting at the dropout (regardless of axle attachments, e.g. mudguard strut) must have a supporting thread length of approx. 8 mm for the axle nut. Fit adapter (1) when dry, do not grease or oil tooting.

SPECTROLUX V6

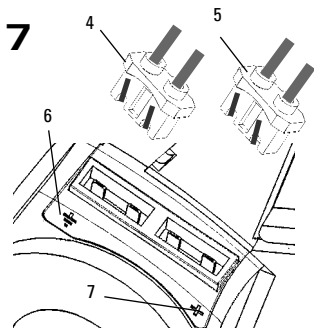

Routing cables

- Route 2-pin cables for front and rear lights along the frame and connect.

Advice:

The dynamo is normally earthed via the axle nut – rane connection. For improved operational reliability, however, we recommend that the earth connections are always used.

Fitting double plug

- Cut double cable from front light and rear light to length (add a few cm for assembly loop) and strip approx. 10 mm.
- Insert earth cables from front light and rear light into the grey double plug = earth (4, Fig. 7) so that 5 mm of the stripped cable end can be folded over towards the small slot on the plug.
- Insert positive cables from front light and rear light into the black double plug = positive (5, Fig. 7) in the same way and fold over 5 mm.
- Insert grey plug (4) into socket with symbol (6, earth) on dynamo and click into place.
- Insert black plug (5) into socket with + symbol (7, positive) on dynamo in the same way. (Fig. 7)

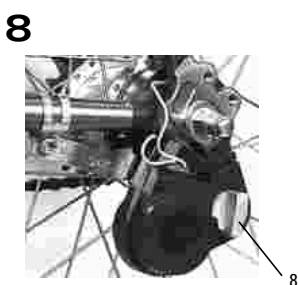

Functional check (Fig. 8)

- Turn control knob (8) to the "ON" position (gearwheel meshes with tothing on the adapter)
- Spin wheel – check that front and rear lights are working. In case of malfunction, please refer to the troubleshooting guide.

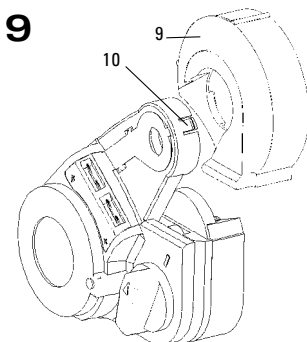

WHEEL CHANGE

- **he following points** in particular **must be observed** when removing and fitting the rear wheel:

- Before removing the wheel, **disconnect both plugs from the dynamo.**
- Before fitting the wheel, remember to insert **the washer between hub and dynamo** (only with coaster brake, see "installing dynamo").
- Check that **the dust cover is in exactly the right position (9, Fig. 9)**. The cover must be engaged into the lug (10) on the housing. (Fig. 9)
- After fitting the wheel, **insert grey plug into socket with ⊥ symbol and black plug into socket with + symbol** (see "fitting double plug").

Caution:

The dynamo's earth (symbol ⊥) must also be assigned to the earth symbol on the front and rear lights. Reversing the cables will cause a short circuit or a much weaker light output.

- **It is also essential to refer to the valid operating instructions for the hub.**

MAINTENANCE / CARE

- The dynamo is maintenance-free
- Do not use any aggressive cleaning agents to clean the dynamo.
- **Do not oil or grease gearwheel on dynamo or tothing on adapter.**

Caution:

The dynamo cannot be opened for repairs – if problems arise, please return it to the manufacturer through your specialist dealer.

TROUBLESHOOTING GUIDE

No.	Fault	Cause	Remedy
1	Only version with brake: Rhythmic knocking noise when cycling	<ul style="list-style-type: none"> • Insufficient distance between adapter and dynamo, 1.5 mm washer not fitted 	<ul style="list-style-type: none"> • Fit washer between hub and dynamo
2	Scraping noise when cycling	<ul style="list-style-type: none"> • Dust cover scraping against adapter tothing 	<ul style="list-style-type: none"> • Fit dust cover in exactly the right position
3	Light does not come on	<ul style="list-style-type: none"> • Dynamo not switched on • Cable connections at front light, rear light or dynamo not exact (no contact) • Earth connections not exact (no contact) • Earth and positive connections reversed • Bulb missing or faulty • Cable damaged – interruption 	<ul style="list-style-type: none"> • Switch on dynamo • Check connections – establish contact (remove corrosion if necessary) • Check connections – establish contact (remove corrosion if necessary) • Ensure correct plug position on front light, rear light and dynamo • Fit bulb or check that it is working • Check cable, renew if necessary

SPECTRO FRONT HUBS

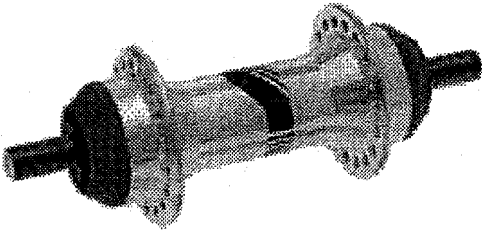

TECHNICAL DATA

		Solid axle	Hollow axle
Over locknut dimension	100 mm	X	X
Axle length		136 mm	107 mm
Length of axle ends		18 mm	3.5 mm
Axle-Ø	Steel	9 x 1 mm	9 mm
Number of spoke holes	36	X	X
Spoke hole-Ø	2.5 mm + 0.15	X	X
Spoke hole reference-Ø		39 mm	39 mm
Distance middle of flange to middle of over locknut dim.		29.6 mm	29.6 mm
Bearing and sealing	Cone/labyrinth	X	X

USE OF QUICK RELEASE DEVICES

(length/thickness of suitable dropouts)

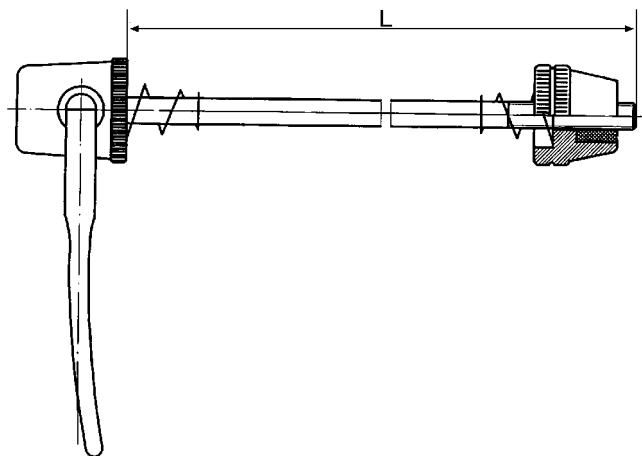

Type	Number		OLD	L	Dropout
Traxx	88 4689 513 002	FW	100	124 mm	3.5–6.5 mm
	88 4689 513 001	FW	100	128 mm	5.0–8.0 mm

SPECTRO FRONT HUBS

1

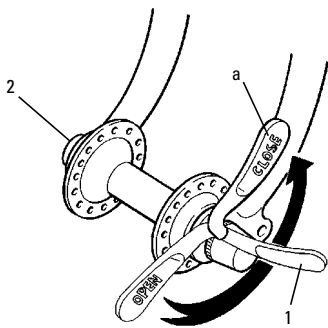

ASSEMBLY

- Fit wheel into dropouts and align
- Fastening wheel/solid axle:
 - Slide washers onto axle ends.
 - Fit axle nuts: Torque 30–40 Nm (266–354 in.lbs.)
- Fastening wheel/quick release (**Fig. 1**):
- Only use quick release devices with the correct length.
- Turn release lever 1 outwards until it is at least at a right angle to the bike.
- Tighten adjusting nut 2 as much as possible by hand.
- Turn release lever 1 to the closed position a (the word “close” is visible from the outside).

After closure, the release lever should be parallel to the fork or frame. If the release lever can be closed relatively easily, the tension force is inadequate.

In this case, open release lever again, tighten adjusting nut 2 slightly and close release lever again.

If considerable force is required to close the lever, open the lever again, undo the adjusting nut slightly and close lever again.

Caution:

Do not tighten wheel by turning the quick release device right round (Fig. 2)!

2

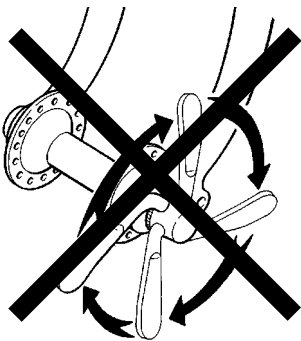

SPECTRO VT 3000/5000 FRONT HUBS WITH DRUM BRAKE

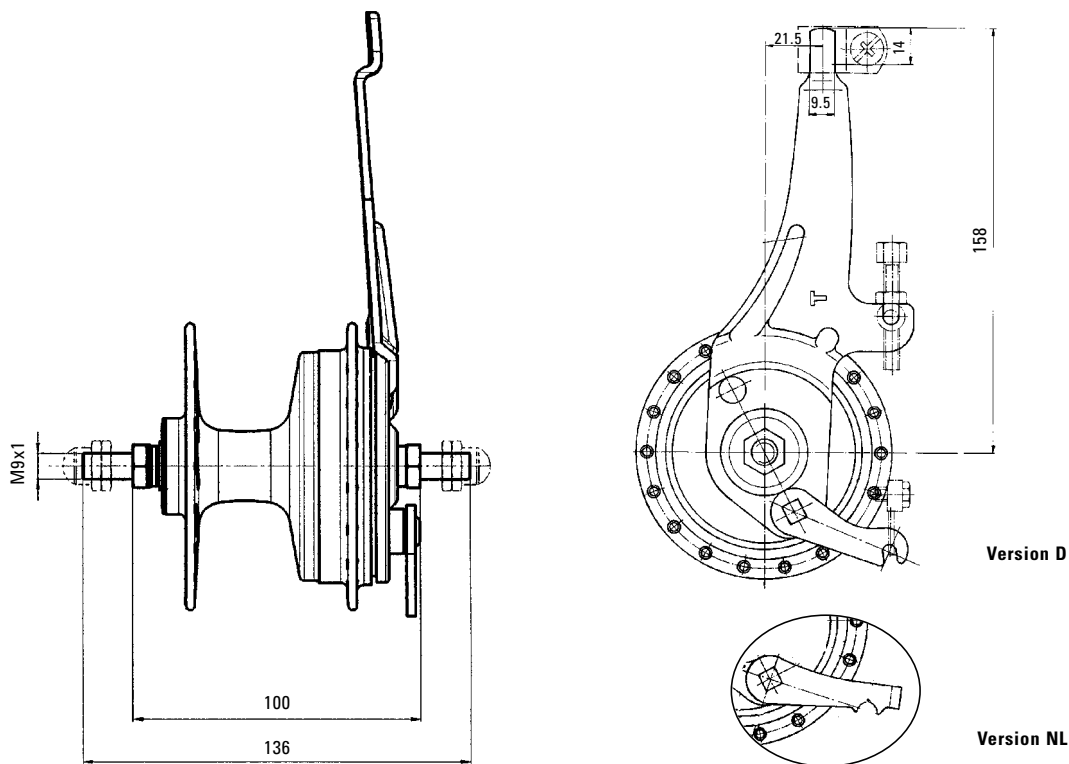

TECHNICAL DATA AND INSTALLATION REQUIREMENTS

- Strength of front fork:
The front fork must be designed so it is not permanently deformed when the wheel is subjected to a torque of 300 Nm.

Caution:

- **There is a risk of accident if unsuitable forks are used!**
- **Not suitable for tandem use.**
- **Wheel size: only 24"/26"/28" wheels are suitable for use.**

Brake lever:

Brake levers with a minimum leverage of 3.8, e.g. Spectro brake lever Art. No. 24 0400 095 001/002, are recommended.

SPECTRO VT 3000/5000 FRONT HUBS WITH DRUM BRAKE

1

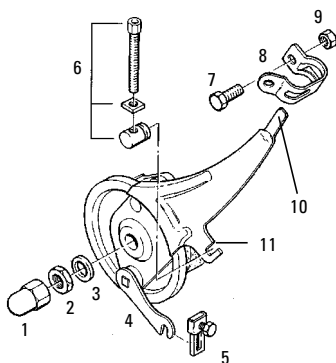

FITTING WHEEL IN FRONT FORK

- Spoke hub as usual.
- Insert wheel into dropouts. Guide the top end of the brake anchor plate (10) into the brazing part of the fork if fitted. If there is no brazing part, use VT pipe clamp (7/8/9, Fig. 1).
- Slide washers or snap rings onto axle ends.
- Fit axle nuts (1). (15 mm wrench, torque 30–40 Nm/266–354 in.lbs.)
- Tighten screw connections (7/9) on VT pipe clamp. (Fig. 1) (Torque approx. 3 Nm/27 in.lbs.)
- Fit cable stop (6) with adjusting bolt (6a) and nut (6b) and insert into the slot on the brake anchor plate. (Fig. 1)
- Turn adjusting bolt down by approx. 2/3 and route the brake cable from the brake handle.
- Push lower brake cable end through adjusting bolt (6a). (Fig. 3)
- Insert lower cable housing end into adjusting bolt (6a).
- Thread brake cable end (5b) into fork unit (5).
- Tighten screw (5a) slightly.
- Attach fork unit (5) to brake lever (4).
- Pull brake cable end (5b) taut with pliers so that fork unit (5) can still be attached and removed (important for changing wheel).
- Tighten screw (5a). (Fig. 3)
- For NL version drum brake hub (with lever 4a, Fig. 2), only use original Holland brake cable (fork unit (5) is not suitable)

2

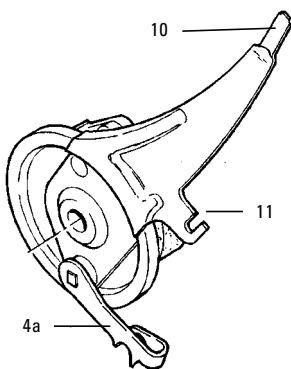

grease get into the brake pads. Oily brake pads reduce braking effect and can cause the brakes to fail completely. This may result in accidents with extremely serious injuries.

- Unscrew lock nut (2a, wrench 15 mm across flats) while counter-holding the dihedron of adjusting cone (a) with a 15 mm hexagon wrench. Remove washer (3a).
- Unscrew adjusting cone (a) and remove axle (e) from the hub shell.
- Clean parts and check for wear.

Assembling hub (Figs. 4 + 5):

- Grease ball retainer (c) and insert in the bearing shells with the balls first. Press in dust cap (d, in case of repairs) flush with the hub shell.
- Insert axle (e), screw on adjusting cone (a) and adjust bearing play. **The mounting must be free from play, but the bearings must not be under pressure.**
- Fit washer (3a), screw on lock nut (2a), hold adjusting cone (a) in place and tighten nut to a torque of 15–20 Nm (132.8–177 in.lbs.).
- Insert brake anchor plate. Pull brake lever (4/4a, Figs. 1 + 2) to the limit position and hold in place to align (centre) the brake shoes in the brake drum.
- Fit washer (3) and tighten lock nut (2) to a torque of 15–20 Nm (132.8–177 in.lbs.).

Fitting front wheel:

- Insert wheel, guiding the top end of the brake anchor plate (10) into the brazed on eye bolt or pipe clamp (8) on the fork, and fit the hub axle into the fork dropouts as far as the limit position.
- Fit washers (not illustrated) to axle ends and tighten axle nuts (1) to a torque of 30–40 Nm (266–354 in.lbs.).
- Insert cable stop (6) with adjusting bolt (6a) and nut (6b) into the slot on the brake anchor plate.
- Attach brake cable with fork unit (5) to brake lever (4). (Fig. 6)

Caution:

Brake anchor plates, brake cables and cable housings should only be replaced by a specialist.

3

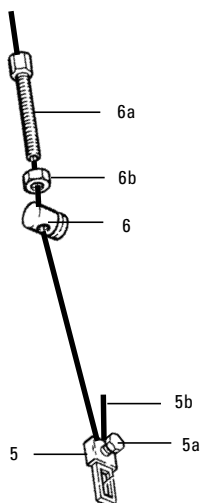

Adjusting brake:

- Push brake lever (4/4a) up towards the brake until resistance is felt (i.e. brake grips)
- Unscrew adjusting bolt (6a) until control cable is taut.
- Release the brake lever and check if the wheel can turn freely; correct at adjusting bolt (6a) if necessary.
- Fit counter nut (6b). (Fig. 3, 10 mm wrench)
- Operate brake lever on handlebars. If the lever hits the handlebar, assembly and/or adjustment work has not been carried out correctly. Repeat the appropriate steps.

DISMANTLING AND ASSEMBLING HUB

Removing front wheel

- Detach control cable at brake lever (if necessary, screw in adjusting bolt (6a) as required), undo both axle nuts (1) using a 15 mm hexagon wrench and remove wheel from the front fork. (Figs. 1 + 3)

Dismantling hub (Figs. 4 + 5):

- Unscrew lock nut (2) and remove complete brake anchor plate.

Caution:

- **The brake anchor plate must be replaced if oil or other substances containing**

Adjusting brake:

- ...if, after an extended period of use, braking effect is reduced or the brake lever can be pulled as far as the handlebar grip. (Fig. 6)
- Unscrew adjusting bolt (6a) until the brake rubs slightly when the wheel is turned.
- Apply brake lever forcefully several times and then, if necessary, turn adjusting bolt (6a) further until the brake rubs again slightly.
- After releasing the brake lever, the front wheel must turn freely; correct at adjusting bolt (6a) if necessary.
- Fit a counter nut to hex nut (6b).
- Repeat adjustment if necessary to make sure brake is ready for operation.

SPECTRO VT 3000/5000

FRONT HUBS WITH DRUM BRAKE

6

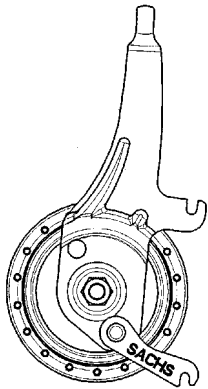

Fig. 4:
VT 3000 version "D"

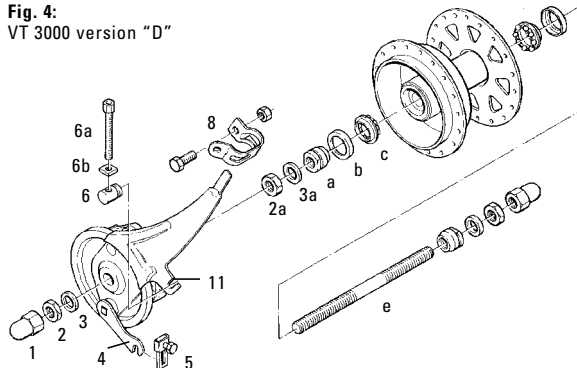
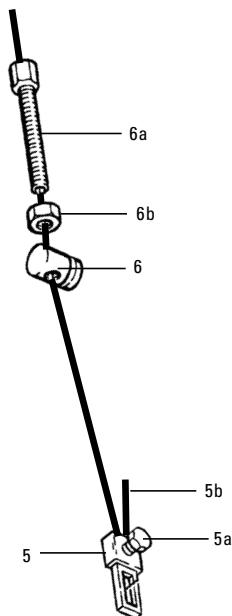
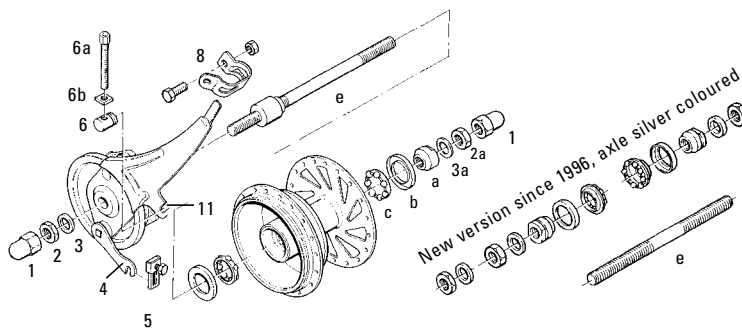

Fig. 5:
VT 5000 version "D"



MAINTENANCE / CARE

- The hub mounting is sufficiently lubricated and essentially maintenance-free.
- Lubricate brake cable regularly. (Cable housing without inner tube.)
- Do not clean hub with water under pressure (e.g. hard jet of water, high-pressure cleaner etc.) – water penetrating could produce corrosion in the brake drum and cause malfunctioning.
- Do not rinse hub with benzene, petroleum etc. as this could produce impurities in the brake pads
- If the front wheel develops too much lateral play, have the mounting adjusted by a specialist.

OPERATION

- The drum brake can be controlled very precisely and provides very effective braking deceleration compared with conventional bicycle brakes. However, the drum brake only reaches maximum braking power after a certain breaking-in period.
- To get used to the new brake, operate the brake lever carefully to acquire a feel for the drum brake's deceleration.

Advice:

The front brake is usually applied using the brake lever on the right of the handlebars. Some bicycle manufacturers may, however, fit the front brake lever on the left side.

SAFETY

Important!

- *If the bicycle is left standing for long periods, surface rust in the brake drum may increase braking effect. For this reason, start by braking gently a few times the next time the bicycle is used to remove the surface rust. This will prevent the brake from locking suddenly.*
- *On long, steep downhill stretches, also use the second brake (rear wheel) alternately to prevent the brakes from heating up excessively.*
- *Do not touch hub after cycling – risk of burning!*
- *If retrofitting the VT 3/5000, the front fork must meet the strength requirements for drum brake hubs.*

SPECTRO BRAKE LEVER

1

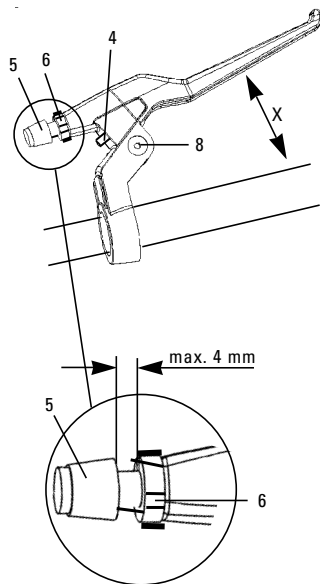

TECHNICAL DATA AND INSTALLATION REQUIREMENTS

Brake cable:

Ø 1.6 mm, with cable head width min. 5.8 mm,
Ø min 6 mm.
lever ratio: 3.7

Pull cable path:

15 mm – making it especially suitable
for SRAM drum brakes.

Handlebar:

Rated value – Ø 22.0...22.4 mm

ASSEMBLY

- Push the brake lever onto the handlebar and line up in position. Tighten fastening bolt (5 mm Allen screw) with a tightening torque of 6...8 Nm.
- After all the components have been fitted, actuate the brake lever strongly several times and then check the brake setting. The instructions of the brake or component manufacturer must be followed.

Caution:

Do not unscrew the adjusting screw (5) for adjusting the brake by more than 4 mm (danger of breakage) – rather carry out the adjustment on the brake itself. Always counterlock the safety nut (6) against the lever housing.

Advice:

Using adjusting screw (4) (2 mm Allen screw), the grip width (X) of the hand lever can be individually adjusted ("reach adjust"). Any play in the hand lever can be adjusted using Allen screw (8). The hand lever must continue to move freely, however.

SPECTRO CRANK SET

TECHNICAL DATA

	Spectro	
Teeth	38	33
Crank length	170 mm	X
low profile	X	X
Chain type	1/2 x 1/8", 1/2 x 3/32"	1/2 x 1/8", 1/2 x 3/32"
Axle length of bottom bracket cassette	120 mm (E12, 116...120 mm)	120 mm
Bottom bracket spindle taper	JIS	JIS
Chain line Lc	44.5 mm	X
Chain guard ring	without	without

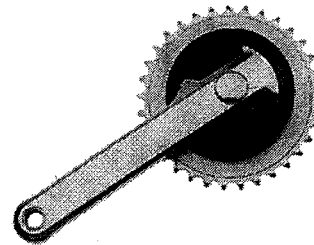
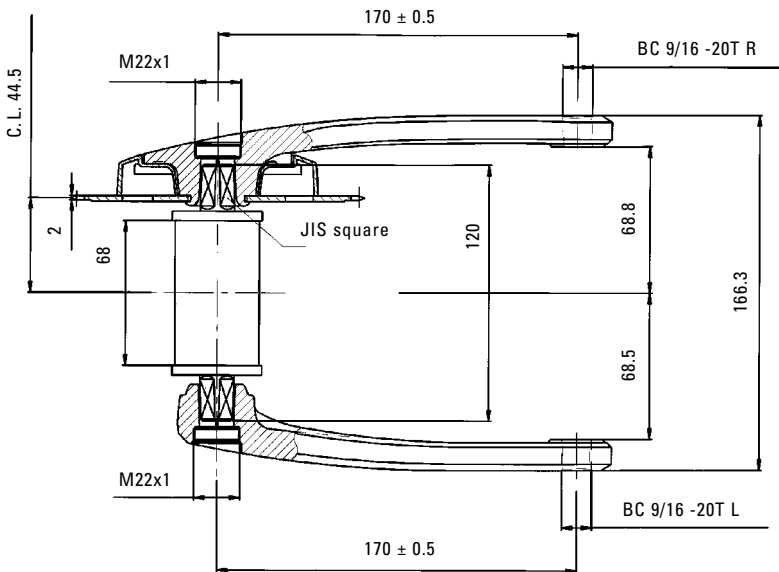

ASSEMBLY REQUIREMENTS

- Suitable bottom bracket cassettes:
Axle length L = 120 mm, symmetric
Exception E12 L = 116...120 mm
Spindle taper JIS
- Suitable chains
1/2" x 1/8" oder 1/2" x 3/32"

ASSEMBLY

- Slide pedal crank onto spindle taper of bottom bracket axle. Do not grease or oil spindle taper!
- Tighten screw of pedal crank/bottom bracket axle connection. Torque 40 Nm.

POWER CHAIN INSTRUCTIONS

TECHNICAL DATA

Type	PC 1	PC 10	PC 31	PC 31S	PC 41
Dimensions	1/2" x 1/8"	1/2" x 3/32"	1/2" x 3/32"	1/2" x 3/32"	1/2" x 3/32"
HG* compatible	-	X	X	X	X
IG* compatible	-	-	X	X	X
Max. num. of sprockets	1	7	8	8	8
Chain connector					
Powerlink	-	-	-	-	X
Powerlink II	-	-	X	X	-
Standard	X	X	X	X	X
Connecting link, 3-parted	X	-	-	-	-
Unit Packing	X	-	-	-	X

*HG/IG sare registered trademarks of Shimano Inc., Japan

APPLICATION

	PC 1	PC 10	PC 31	PC 31S	PC 41
Spectro T3	X	X	X	X	X
Spectro P5	X	X	X	X	X
Spectro S7	X	X	X	X	X
Spectro E12	-	X	X	X	X
Spectro 3x7	-	-	X	X	X

1

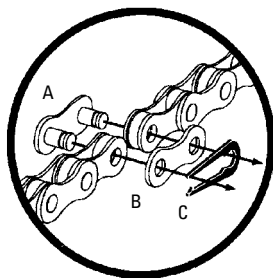

SPECIAL FEATURES PC 31S/PC 41

- Chamfered outer and inner plates
- Narrow width
- Pins chromized and heat-treated
- Power Link

ASSEMBLY POWER CHAIN PC 1 (1/2" X 1/8" SINGLE AND MULTI-SPEED HUBS)

Chain length:

- Measure the worn chain and shorten the new chain to the same length (No. of links).
- For frame versions with suspension please read bicycle producer's instruction

Closing chain:

- Fit the shortened chain, bring the two ends together and connect with the chain lock. The chain lock consists of an outer plate with pins (A), an outer plate (B) and a retaining spring (C). **(Fig. 1)**
- Insert outer plate with pins (A) into the chain ends, attach outer plate (B) and press chain lock together (A+B). **(Fig. 1)**
- Attach retaining spring (C) with the closed end of the retaining ring pointing in the direction of chain travel. **(Fig. 2)**.
- Slide retaining spring in the direction of arrow X **(Fig. 2)** to engage it in the grooves in the pins.

2

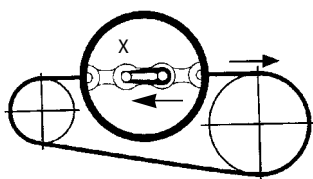

POWER CHAIN INSTRUCTIONS

3

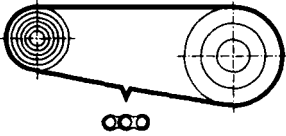

ASSEMBLY (DERAILLEUR/CHAINS 1/2" X 3/32")

Chain length:

(An assembly tool will be required to shorten the chain, see also "Closing chain".)

- Replacing a worn chain: measure the worn chain and shorten the new chain to the same length (No. of links)
- Initial assembly:
 - Shorten chain to the length specified by the derailleur manufacturer
 - SRAM derailleurs: place chain over largest front chainwheel and largest rear sprocket and add 2 links or 1 link + Power Link (Fig. 3)
 - For frame versions with suspension, please read bicycle producer's instruction.

MAINTENANCE/CARE

- Regular lubrication will extend the chain's service life
- Apply oil to the chain rollers and allow to work in
- Clean dirty chains before oiling.
- Do not use any grease-dissolving or acidic agents. Cleaning agent must be rinsed off after a few minutes with water. Apply oil after chain is completely dried.

Caution:

- **Make sure the retaining spring on the chain lock resp. Power Link is locked exactly into place.**
- **Always use a new chain lock resp. Power Link when fitting a new chain. Failure to shorten the chain properly or to lock it exactly into place may cause damage to the chain and eventually total chain failure, material damage or the rider to fall off his bicycle resulting in injury.**
- **Worn sprockets should also be replaced when a new chain is fitted.**

4

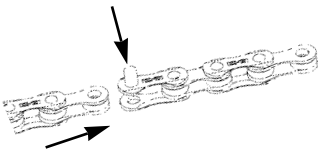

Closing chain (standard version with clamping pin):

- Fit chain, bring the two ends together and press pin through with assembly tool (Fig. 4). The pin must extend by the same amount at both outer plates. It must be possible to move the connecting link slightly. (Fig. 4)
- The use of SRAM assembly pliers is recommended: version for chains PC 41, PC 51, PC 80R, PC 61, PC 91, Art. No. 2799 980 001 (Fig. 5)

5

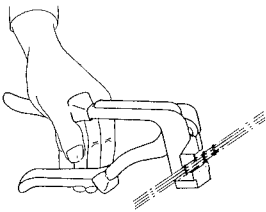

Closing chain (Power Link and Power Link II connecting links):

- ...every chain is only as strong as its weakest link – traditionally this is the connecting link. In contrast, the Power Link connection is just as strong and durable as every other link in the chain. And it can be opened and closed as many times as you want without using tools. Fit chain, bring the two ends together and insert both halves of the Power Link into the chain ends. (Fig. 6)
- Press both halves of the connecting link together (Fig. 7) and lock in place by pulling the chain apart. (Fig. 8)
- To disassemble: Press both plates of the connecting link together (Fig. 7) while sliding the chain ends together (unlock). Remove the two halves of the link from the chain ends.

6

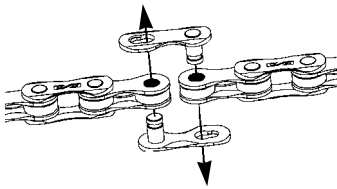

7

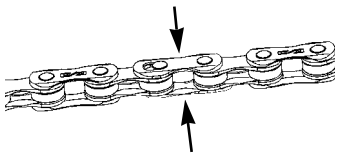

Caution:

- "Power Link" (black) only for chain PC 41
- "Power Link II" (grey, "PL II" marked on the plate) only for chains PC 31, PC 31S

8

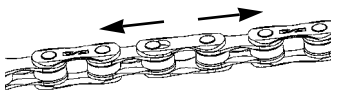

APPENDIX

APPENDIX

SPARE PARTS

You can find an extensive spare parts program in SRAM's Spare Parts List Ref.Number 0368 201 060.

GLOSSARY

CHAIN RATIO

The chain ratio is calculated from the ratio of the number of the teeth on the chain wheel and on the rear sprocket.

Example: chain ratio $i = \frac{44}{24} = 1.8$

CLICKBOX

In combination with thumb shifters for Spectro P5 and S7. When removing the rear wheel, the Clickbox is simply detached from the axle end of the hub and fitted again afterwards. Adjustment of the gears is permanently integrated.

MINI CLICKBOX

In combination with rotational shifters for Spectro P5 and S7. When removing the rear wheel, the Mini Clickbox is simply detached from the axle end of the hub and fitted again afterwards. It is not necessary to readjust the gears.

CLICKSTICK

The Spectro E12 Clickstick allows the rear wheel to be removed and fitted quickly; gear settings remain the same. A plastic cover protects both technology and clothing.

DUAL DENSITY DESIGN

Two different soft grip materials on Spectro fixed grips for improved comfort. Available for Spectro P5, S7, E12, 3x7.

LOCATING SLEEVE

Connects the shifting cable of the Spectro T3 and 3x7 to the hub, ensures easy assembly, removal and adjustment of the shifting mechanism.

LOGICAL SHIFTING

When upshifting and downshifting the Spectro 3x7, the right and left grips are each turned in the same direction; this makes gear changing easy and logical.

POWER GLIDE

Sprocket cassette/sprocket package for Spectro 3x7. Power Glide technology allows precise shifting, even under high loads, and a long service life.

REACH ADJUST

Using the hex socket screw on the brake lever, the reach of the brake lever can be adjusted individually to suit hand size.

RETAINING WASHERS

For Spectro T3, P5, S7 and 3x7, these prevent the axle from twisting in the frame.

The toothed side of the retaining washers must be against the frame, the prongs must engage in the frame dropout.



SRAM

DEALER HELPDESK NUMBERS:

North America

(8 0 0) - 3 4 6 - 2 9 2 8

Europe

+ 8 0 0 / 7 7 2 6 4 3 5 7

**CORPORATE
HEADQUARTERS**

SRAM Corporation
361 West Chestnut Street
Chicago, IL 60610
Ph: +312-664-8800
Fax: +312-664-8826

**THE
NETHERLANDS**

SRAM Europe Sales &
Services B.V.
Basicweg 12-05
3821 BR Amersfoort
The Netherlands
Ph: +31-33-4506060
Fax: +31-33-4570100
email:
srameurope@sram.com

TAIWAN

SRAM Corporation
No. 1598-9 Chung Shan
Road Shen Kang Hsiang
Taichung County Taiwan,
R.O.C.
Ph: +886-4-561-3678
Fax: +886-4-561-3686