



CYCLE

ACCESSORIES · FITTINGS · TYRES

BICYCLES · MOTOR CYCLE ACCESSORIES

METALS · SPORTS · TOYS · BABY CARS

Brown Brothers LEATHER

ALLIED COMPANIES

THOMSON and BROWN BROTHERS LIMITED

BROWN BROTHERS (AIRCRAFT) LTD.

BROWN BROTHERS (IRELAND) LTD.

BALLS, BALL RETAINERS



STEEL BALLS
BEST QUALITY



SKEFKO

No. 25/B1d/8j	$\frac{1}{8}$ " dia.	100 per box	No. 25/B1f/106	$\frac{1}{8}$ " dia.	100 per box	No. 25/B1h/205	$\frac{1}{4}$ " dia.	100 per box
25/B1d/810		1,000 ..	25/B1f/1304		1,000 ..	25/B1h/2108		1,000 ..
25/B1e/101	$\frac{1}{8}$ " ..	100 ..	25/B1g/200	$\frac{1}{8}$ " ..	100 ..	25/B1k/305	$\frac{1}{8}$ " ..	100 ..
25/B1e/907		1,000 ..	25/B1g/1804		1,000 ..	25/B1l/409	$\frac{1}{8}$ " ..	100 ..

HOFFMANN

No. 25/B5b/201	$\frac{1}{8}$ " dia.	100 per box	No. 25/B5g/200	$\frac{1}{8}$ " dia.	100 per box	No. 25/B8c/704	$\frac{1}{2}$ " dia.	100 per box
25/B5b/1902		1,000 ..	25/B5g/1804		1,000 ..	25/B8d/811	$\frac{1}{2}$ " ..	100 ..
25/B5c/11	$\frac{1}{8}$ " ..	100 ..	25/B5h/205	$\frac{1}{8}$ " ..	100 ..	25/B8e/1006	$\frac{1}{2}$ " ..	100 ..
25/B5c/804		1,000 ..	25/B5h/2108		1,000 ..	25/B8g/1205	$\frac{1}{2}$ " ..	100 ..
25/B5d/8j	$\frac{1}{8}$ " ..	100 ..	25/B5k/305	$\frac{1}{8}$ " ..	100 ..	25/B8k/1701	$\frac{1}{2}$ " ..	100 ..
25/B5d/810		1,000 ..	25/B5l/409	$\frac{1}{8}$ " ..	100 ..	25/B8m/2200	$\frac{1}{2}$ " ..	100 ..
25/B5e/101	$\frac{1}{8}$ " ..	100 ..	25/B8a/600	$\frac{1}{2}$ " ..	100 ..	25/B8n/3508	$\frac{1}{2}$ " ..	100 ..
25/B5e/907		1,000 ..	25/B8b/703	$\frac{1}{2}$ " ..	100 ..	25/B8z/5403	$\frac{1}{2}$ " ..	100 ..
25/B5f/106	$\frac{1}{8}$ " ..	100 ..				25/B9d/7600	1" ..	100 ..
25/B5f/1304		1,000 ..						

Prices of larger sizes quoted on application.

Millimetre sizes can be obtained to special order in a few days.

Brass, Manganese-Bronze and Phosphor-Bronze Balls quoted for on application.

SUITABLE FOR:—

"Eadie" (New Pattern), "Perry" and "B.W."

Coaster, standard models ($1\frac{1}{2}$ ").

No. 25/B17a/7	each -/10
25/B17a/609		per doz. —

"Eadie" (Old Pattern)

Coaster, standard models, small ($1\frac{1}{2}$ "), also "B.S.A." 3-Speed (large size) ($1\frac{1}{2}$ ").

No. 25/B18a/7	each -/7 $\frac{1}{2}$
25/B18a/600		per doz. —

BALL RETAINERS
(OR CAGES)

Prices include Steel Balls fitted complete

SUITABLE FOR:—

"Eadie" (Old Pattern).

Coaster, standard models ($1\frac{1}{2}$ ").

No. 25/B18k/6	each -/9
25/B18k/609		per doz. —

"B.S.A."

3-Speed (small size) $\frac{1}{2}$ " dia. with seven $\frac{1}{8}$ " balls.

No. 25/B18m/4	each -/6
25/B18m/309		per doz. —

PRICES shown do NOT include PURCHASE TAX which will be charged at current rates where applicable

Branches
Aberdeen, Aston, Bolton
Birmingham, Bournemouth
Bristol, Cardiff, Carlisle
Croydon, Dublin, Dundee
Exeter, Glasgow
Hull, Inverness, Leeds

Head Office and Warehouse, Wholesale only

GREAT EASTERN STREET, LONDON, E.C.2

126 GEORGE STREET, EDINBURGH, 1

Branches
Liverpool, Manchester
Newcastle-upon-Tyne
Nottingham, Oxford, Preston
Reading, Southampton
Sheffield, Tinsley
Wolverhampton

BRACKET CUPS AND LOCK RINGS (For Cotterless Brackets)



BRACKET CUPS, ADJUSTING

For Cotterless Brackets.

1 1/2" x 24 Right-Hand Thread.

"B.W." No. 1.

Shallow Pattern.

No. 25/B492c/600 .. per doz. 9/-

"T.D.C." No. C11.

Standard.

No. 25/B501b/600 .. per doz. 9/-

Oversize.

No. 25/B501p/904 .. per doz. 14/-

"B.W." No. 2.

Standard.

No. 25/B503b/700 .. per doz. 10/6

"Brampton"

Standard No. B202.

No. 25/B504b/800 .. per doz. 9/-

Extra Deep No. B204.

No. 25/B504x/804 .. per doz. 9/6

"B.S.A." Genuine.

No. 25/B505c/1000 .. per doz. 15/-

For Tandem 1 1/2" x 26" Thread.

"Brampton" No. B621.

No. 25/B504x/704 .. per doz. 11/-

"Chater Lea" No. B349.

No. 25/B507c/201 .. each 2/10

25/B507c/2500 .. per doz. —



LOCK RINGS

(For Adjusting Cups).

"T.D.C." No. C15.

Standard (Slotted).

No. 25/B521c/308 .. per doz. 5/6

(Oversize Slotted).

No. 25/B521p/500 .. per doz. 7/6

"B.W." No. 9.

Standard (Slotted).

No. 25/B523b/401 .. per doz. 6/-

"Brampton" No. B075.

Standard (Slotted).

No. 25/B524b/308 .. per doz. 8/6

"B.S.A." Genuine.

Standard (Pinhole).

No. 25/B525c/507 .. per doz. 7/-

For Tandem.

"Brampton" No. B622.

No. 25/B524x/408 .. per doz. 7/-

"Chater Lea" (Pinhole).

No. 25/B527c/1600 .. per doz. 22/-



BRACKET CUPS, FIXED

For Cotterless Brackets.

1 1/2" x 24 Left-Hand Thread.

"B.W." No. C13.

Standard (Pinhole).

No. 25/B531c/604 .. per doz. 9/6

Oversize (Pinhole).

No. 25/B531p/1000 .. per doz. 15/-

"B.W." No. 3.

Standard (With two flats).

No. 25/B533b/801 .. per doz. 11/3

"Brampton"

Standard (Pinhole) No. B202.

No. 25/B534b/604 .. per doz. 9/6

Extra Deep (With two Flats) No. B203.

No. 25/B534x/704 .. per doz. 11/-

"B.S.A." Genuine.

Standard (With two flats).

No. 25/B535c/1000 .. per doz. 13/-

For Tandem 1 1/2" x 26" Thread.

"Brampton" (With two Flats and two

Pinholes) No. B620.

No. 25/B534x/1000 .. per doz. 15/-

"Chater Lea" (With two Flats) No. B50.

No. 25/B537c/201 .. each 2/10

25/B537c/2500 .. per doz. —

CYCLO BRACKET CUP
SCREWING GRANK

8" long steel crank with handle, with 1/2" dia. hole to fit over bracket spindle, and fitted with double-ended replaceable hardened peg to fit into pinhole bracket cups.

Gun black finish.

Model No. C/2.

No. 25/B603c/1000 .. each 15/-

Spare Pegs for above.

No. 25/B603d/106 .. each 2/3

BAYLISS-WILEY BRACKET
CUPS AND LOCK RINGS FOR
"B.W." PATENT OIL BATH
UNIT BRACKET SET

1 1/2" x 24 Right-Hand Thread, adjusting.

No. 25/B503c/7 .. each —/10

25/B503c/760 .. per doz. —

1 1/2" x 24 Left-Hand Thread, Flanged.

No. 25/B533c/9 1/2 Black each 1/1

25/B533c/903 .. per doz. —

Lock ring, slotted with very slight tapered edge flange for above.

No. 25/B523c/9 1/2 .. each 1/1

25/B523c/903 .. per doz. —

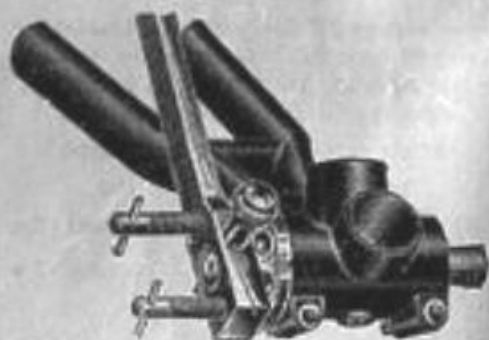
CYCLO BRACKET CUP DRIVER
OR REMOVER

For use with Cottered or Cotterless Cups.

No. 25/B603/1206 .. each 18/9

Discs only for above.

No. 25/B603a/406 .. each 6/9

Screws only for above.

No. 25/B603b/106 .. each 2/3

PRICES shown do NOT include PURCHASE TAX which will be charged at current rates where applicable

Branches
Aberdeen, Aston, Belfast
Birmingham, Exeter, Glasgow
London, Cardiff, Carlisle
Croydon, Dublin, Dundee
Sancti Spiritus, Glasgow
Newcastle, Leeds

Head Office and Workshops, Wholesale only:

GREAT EASTERN STREET, LONDON, E.C.2

116 GEORGE STREET EDINBURGH, 1

Branches
Liverpool, Manchester
Newcastle-upon-Tyne
Nottingham, Oxford, Preston
Reading, Southampton
Sheffield, York
Wolverhampton

BRACKET REAMER, SPINDLES, SHELLS, ETC.



"B.W." PATENT OIL BATH UNIT
Comprising sleeve fitted with two bracket cups, lock ring, steel balls and chromium bracket spindle complete.

1 1/2" C.L.

No. 25/B675a/404 each 6/1

1 1/2" C.L., G.C.C.

No. 25/B675b/404 each 6/1



"B.W." BOTTOM BRACKET REAMER

For clearing existing 1 1/2" diameter screwed bracket shells.

No. 25/B675r/8400 each



BOTTOM BRACKET SPINDLES
For Cotterless Cups.

"T.D.G."

1 1/2" C.L. A 1 1/8" x B 2" x C 1 1/8"

No. 25/B813b/104 No. C16/2 .. each 2/-

25/B813b/1000 per doz. —

1 1/2" C.L., G.C.C. A 1 1/8" x B 2" x C 1 1/8"

No. 25/B812d/104 No. C16/4 .. each 2/-

25/B812d/1000 per doz. —

"B.B.L."

For Hercules Standard. (I,2)

1 1/2" C.L., G.C.C. A 1 1/8" x B 2" x C 1 1/8"

No. 25/B814b/104 each 2/-

25/B814b/1000 per doz. —

For Hercules Carrier. (L.)

1 1/2" C.L., G.C.C. A 1 1/8" x B 2 1/8" x C 1 1/8"

No. 25/B814k/104 each 2/-

25/B814k/1000 per doz. —

For 1937/9 Models.

Plain from end to race, without shouldered ends.

As Raleigh Pattern A8.

A 1 1/8" x B 2 1/8" x C 1 1/8"

No. 25/B816l/108 each 2/6

As Raleigh Pattern A16.

A 1 1/8" x B 2 1/8" x C 1 1/8"

No. 25/B816m/108 each 2/6

As Raleigh Pattern A16 G.C.C.

A 1 1/8" x B 2 1/8" x C 1 1/8"

No. 25/B816n/108 each 2/6

DIMENSION SYMBOLS

← A → ← B → ← C →



A = Length from race to end of spindles for left-hand crank.

B = Centres.

C = Length from race to end of spindles for right-hand crank.



BRAMPTON COTTERLESS SHELL

Size 1 1/4" x 1 1/4" x 1" x 1 1/2" C.L.
67° and 62°. (No. 830203)

No. 25/B686k/204 each 3/6

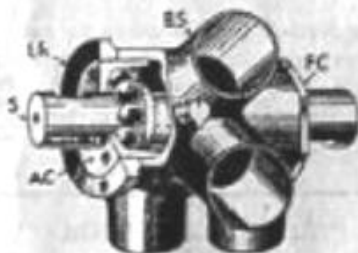

CHATER LEA GENUINE BOTTOM BRACKET SPINDLES

Chromium Plated. For Safety.

1 1/2" C.L. A 1 1/8" x B 2 1/8" x C 1 1/8"

No. 25/B852b/209 1/2 No. 1007 .. each 3/6

For use with double chain wheel.

(Suitable for Chater Lea bottom brackets only.)

Chromium Plated.

No. 25/B856l/307 1/2 No. 1240/1 .. each 5/-

For Tandem.

Chromium Plated. 1 1/2" C.L.

No. 25/B858B/307 1/2 No. 1240 .. each 5/-

Chromium Plated.

No. 25/B856l/307 1/2 No. 1240/1 .. each 5/-

For Tandem.

Chromium Plated. 1 1/2" C.L.

No. 25/B858B/307 1/2 No. 1240 .. each 5/-

Chromium Plated.

No. 25/B856l/307 1/2 No. 1240/1 .. each 5/-

For Tandem.

Chromium Plated. 1 1/2" C.L.

No. 25/B858B/307 1/2 No. 1240 .. each 5/-

Chromium Plated.

No. 25/B856l/307 1/2 No. 1240/1 .. each 5/-

For Tandem.

Chromium Plated. 1 1/2" C.L.

No. 25/B858B/307 1/2 No. 1240 .. each 5/-

Chromium Plated.

No. 25/B856l/307 1/2 No. 1240/1 .. each 5/-

For Tandem.

Chromium Plated. 1 1/2" C.L.

No. 25/B858B/307 1/2 No. 1240 .. each 5/-

Chromium Plated.

No. 25/B856l/307 1/2 No. 1240/1 .. each 5/-

For Tandem.

Chromium Plated. 1 1/2" C.L.

No. 25/B858B/307 1/2 No. 1240 .. each 5/-

Chromium Plated.

No. 25/B856l/307 1/2 No. 1240/1 .. each 5/-

For Tandem.

CHATER LEA GENUINE BRACKET SHELL

For Safety Rigid Sets.

For Upright Sets.

Size 1 1/2" x 1 1/2" x 1 1/2" C.L. (No. 1563-1.)

Height 10 1/2", 6 1/2" and 6 5/8".

For 1" Stays. (No. 1563.)

No. 25/B698e/606 Plain .. each 9/-



BRAMPTON BOTTOM BRACKET SPINDLES

Black Finish.

For Pinhole Cups.

1 1/2" C.L. A 1 1/8" x B 1 1/8" x C 1 1/8"

No. BBA042

No. 25/B842/ per doz.

1 1/2" C.L., G.C.C. A 1 1/8" x B 1 1/8" x C 1 1/8"

No. BBA002

No. 25/B842d/ per doz.

1 1/2" C.L., G.C.C. A 1 1/8" x B 2 1/8" x C 1 1/8"

No. BBA279

No. 25/B842l/ per doz.

For Milled or Cotterless Cups.

1 1/2" C.L. A 1 1/8" x B 2 1/8" x C 1 1/8"

No. BBA284

No. 25/B843/1000 per doz. 24/-

1 1/2" C.L., G.C.C. A 1 1/8" x B 2 1/8" x C 1 1/8"

No. BBA285

No. 25/B843d/1000 per doz. 24/-

PRICES shown do NOT include PURCHASE TAX which will be charged at current rates where applicable

Branche
Aberdeen, Aston, Belfast
Birmingham, Southampton
Bristol, Cardiff, Carlisle
Croydon, Dublin, Dundee
Exeter, Glasgow
Hull, Liverpool, Leeds

Head Office and Warehouse, Wholesale only:

GREAT EASTERN STREET, LONDON, E.C.2

126 GEORGE STREET EDINBURGH, 2

Branche
Doverport, Manchester
Newcastle-upon-Tyne
Nottingham, Oxford, France
Reading, Southampton
Sheffield, Truro
Waterbury

BRACKET SPINDLES BRACKET TAPS



CYCLO SPECIAL BOTTOM BRACKET SPINDLES

For Rosa Swinging Cranks.

For Model No. 66A with two cotter ways on right-hand side.

No. 25/B866/304 each 5/-

Cycle Non-Standard made to customer's own pattern. Suitable for Rosa Swinging Cranks.

No. 25/B867/608 each 10/-



BAYLISS-WILEY BOTTOM BRACKET SPINDLES

Made from 40-Ton Tensile Steel.

1 1/2" C.L. A 1 1/8" x B 2 1/8" x C 1 1/2".

No. 15R.

No. 25/B862n/304 each 4/6



CYCLO BOTTOM BRACKET SPINDLES

Extra light in weight with small diameter spindle shoulders, and with 3/8" hole running throughout for cotterless brackets.

Chromium Plated. A 1 1/8" x B 2 1/8" x C 1 1/2".
No. 25/B862b/400 1 1/2" C.L. each 6/-

For Juvenile Plain Bearing.

4" long x 1/2" dia. for 1/2" cotters.

Cadmium Plated.

No. 25/B878k/100 each 1/6

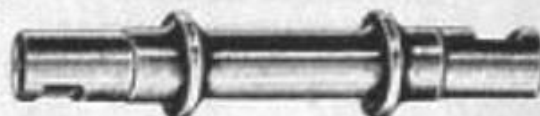

PHILLIPS BOTTOM BRACKET SPINDLES

For Cotterless Chromium Plated.

1 1/2" C.L. G.C.C. (F1-1).

On Display Cards of 6 axles.

No. 25/B869c/802 per card 12/3

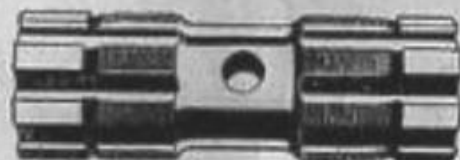

BRACKET TAP

(B.S.A. Standard Size.)

1 1/2" x 24 thread with left and right-hand threads combined.

Complete with Tommy Bar.

No. 25/B905e/1709 each

"T.D.C. LIGHTWEIGHT" BOTTOM BRACKET SPINDLES

Steel, Chromium Plated finish with 1/2" dia. hole drilled throughout.

1 1/2" C.L. No. C16/2.

No. 25/B820/208 each 4/-

FOR HUB SPINDLES
See HUB SPARES

BRACKET TAP (B.S.A. Standard Size)

1 1/2" diameter x 24 thread.

No. 25/B905e/1000 Right hand each

25/B905f/1000 Left hand ..

1 3/8" (1-45) x 26 thread for Brampton Tandem, etc.

No. 25/B905s/1206 Right hand each

25/B905t/1206 Left hand ..



BRACKET TAPS

(B.S.A. Standard Size.)

1 1/2" diameter x 24 thread. British Made.

Right hand.

No. 25/B905a/1608 each

Left hand.

No. 25/B905b/1608 each

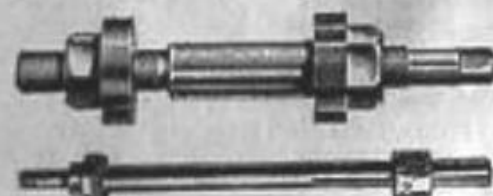

"B.B.L." BOTTOM BRACKET CLEARING TAPS

B.S.A. Size. 1 1/2" diameter x 24 thread.

Taps, complete with guide.

No. 25/B907a/3600 Right hand. each

25/B907b/3600 Left hand. ..

Replacement taps only.

25/B907e/2010 Right hand ..

25/B707f/2010 Left hand ..

Guide collars

25/B907g/205

PRICES shown do NOT include PURCHASE TAX which will be charged at current rates where applicable

Branches
Aberdeen, Aston, Bolton
Birmingham, Bournemouth
Bristol, Cardiff, Carlisle
Croydon, Dublin, Dundee
Exeter, Glasgow
Hull, Ipswich, Leeds

Head Office and Warehouse, Wholesale only:

GREAT EASTERN STREET, LONDON, E.C.2

124 GEORGE STREET EDINBURGH, 2

Branches
Liverpool, Manchester
Newcastle-upon-Tyne
Nottingham, Oxford, Preston
Reading, Southampton
Stoke-on-Trent
Wolverhampton

BRAKES (Cable Models)—SIDE PULL

"DOHERTY" CALIPER BRAKES

Polished Light Alloy Centre Bolt Fitting with hooded lever and clip for both $\frac{1}{2}$ " and $\frac{3}{8}$ " handlebar, with narrow stirrup to suit 26" or 27" rims. Small lever arm fitted under adjusting screw, so as to open out stirrup for easy removal of wheel.

Silver Best Quality Waterproof Outer Cable. Boxed.

No. 25/B1304b/1108	Front	each 17/6
25/B1304e/1108	Rear, Gent.'s	17/6

All Steel. Chromium Plated with solid steel lever. Fitted adjustable centre bolt and domed nuts. Silver Best Quality Waterproof Outer Cable. Boxed.

No. 25/B1304L/604	Front	each 9/6
25/B1304m/608	Rear, Gent.'s	10/-
25/B1304n/808	.. Lady's	10/-

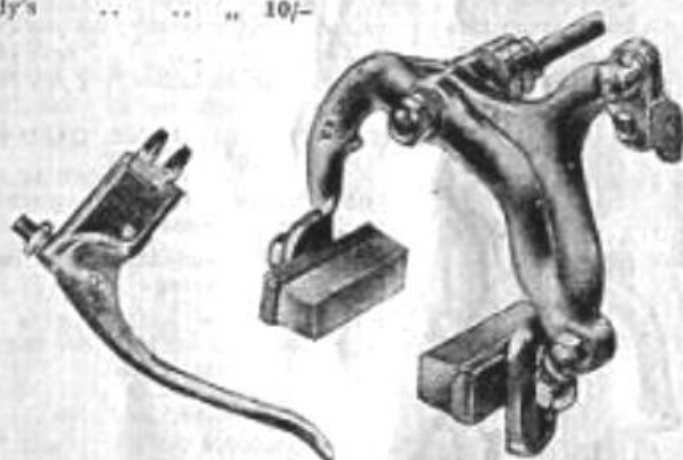
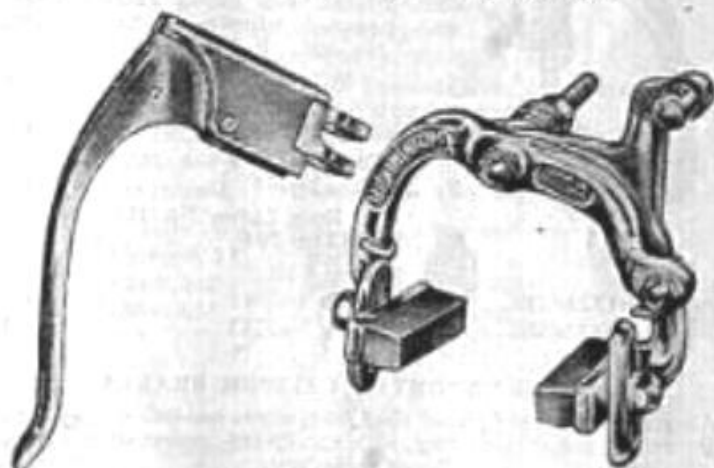

"G.B." HYDUMINIUM LIGHT ALLOY CALIPER BRAKES

Polished finish, No. 2 silver, waterproof covered cable, finger tip cable adjustment at lever end. Centre bolt fitting.

Maximum guard clearance, stirrup with shoes adjustable for 26" or 27" rims, with hooded lever and clip for $\frac{1}{2}$ " or $\frac{3}{8}$ " handlebar.

No. 25/B1305b/1208	Front	each 19/-
25/B1305e/1300	Rear, Gent.'s	19/6

Fitted with ordinary type tourist lever and clip for $\frac{1}{2}$ " or $\frac{3}{8}$ " handlebar.

No. 25/B1305h/1208	Front	each 19/-
25/B1305m/1300	Rear, Gent.'s	19/6

"G.B." HYDUMINIUM LIGHT ALLOY CALIPER BRAKES "GRANDTOUR" MODEL

Polished finish with No. 2 silver waterproof covered cables, finger tip cable adjustment at lever end. Centre bolt fitting fitted with ordinary type tourist lever and clip for $\frac{1}{2}$ " or $\frac{3}{8}$ " handlebar.

Specially designed for touring.

No. 25/B1307h/1208	Front	each 19/-
25/B1307m/1300	Rear, Gent.'s	19/6

"G.B." HYDUMINIUM LIGHT ALLOY CALIPER BRAKES "COUREUR" MODEL

Polished finish with No. 2 silver waterproof covered cable, finger tip cable adjustment at lever end. Centre bolt fitting special small stirrups designed for road-racing machines, shoes adjustable for 26" or 27" rims. With hooded racing levers and clip for $\frac{1}{2}$ " or $\frac{3}{8}$ " handlebar.

No. 28/B1306b/1208	Front	each 19/-
25/B1306e/1300	Rear, Gent.'s	19/6

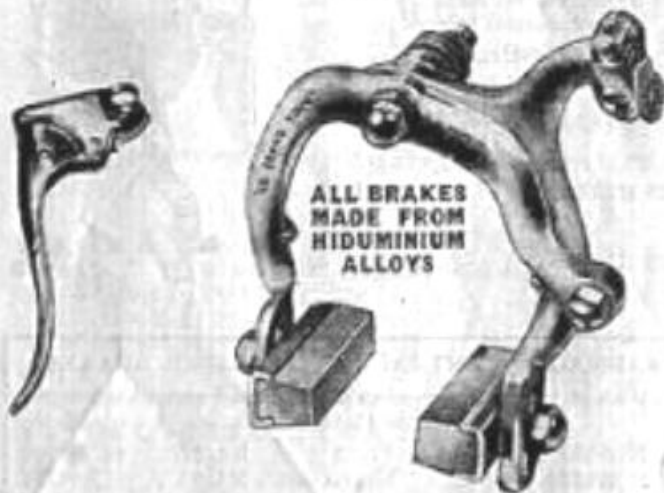

ALL BRAKES
MADE FROM
HYDUMINIUM
ALLOYS

PRICES shown do NOT include PURCHASE TAX which will be charged at current rates where applicable

Branches
Aberdeen, Accor, Belfast
Birmingham, Bournemouth
Bristol, Cardiff, Coleraine
Croydon, Dublin, Dundee
Eastbourne, Glasgow
Hull, Ipswich, Leeds

Head Office and Warehouses, Wholesale only:

GREAT EASTERN STREET, LONDON, E.C.2

136 GEORGE STREET EDINBURGH, 2

Branches
Liverpool, Manchester
Newcastle-upon-Tyne
Nottingham, Oxford, Preston
Reading, Southampton
Sheffield, Truro
Wolverhampton

BRAKES (Cable Models)—SIDE and CENTRE PULL—continued

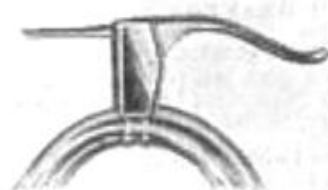
STRATA LIGHT ALLOY
CALIPER BRAKES

Polished finish, silvered waterproof covered cable, centre bolt fitting, fitted with hooded lever and $\frac{1}{2}$ " clips

No. 25/B1308a/908	Front	each 14/6
25/B1308b/1004	Rear, Gent.'s	15/6
25/B1308ab/1908	Front and Rear (for Gent.'s) per pair	29/6
25/B1308c/1006	Rear, Ladies'	each 16/-
25/B1308ac/2000	Front and Rear (for Ladies') per pair	30/-

"GRIP-IT" DE LUXE CALIPER
CABLE BRAKE

British made, with waterproof covered cable.

Fitted with patent adjustable ring bearing.

Stirrup and centre bolt fitting to go through crown and top back stay bridge. Chromium Plated.

Front, for Gent.'s or Ladies'.	
No. 25/B1326b/604	No. 56 .. each 9/6
Rear, for Gent.'s.	
No. 25/B1326a/607	No. 57 .. each 9/10

"ASHBY" CENTRAL PULL
CALIPER BRAKES

With waterproof covered cables and solid metal levers.

Nickel Plated Finish.

Front.

No. 25/B1330a/400 .. each 6/-

Rear, Gent.'s.

No. 25/B1330d/400 .. each 6/-

Rear, Ladies'.

No. 25/B1330i/400 .. each 6/-



"RADNALL" CENTRAL PULL CALIPER BRAKES

With waterproof covered cables and solid metal levers.

Chromium Plated Finish.

No. 25/B1330b/604	Front	No. 52 ..	each 9/6
25/B1330e/607	Rear, Gent.'s	No. 53 ..	9/10

WEBB "UNIVERSAL" CALIPER
BRAKES

With silver waterproof cables, non-fray inner wire and bevelled arches. Complete with pressed steel racing pattern levers with patented adjustment for position. No. 300. Boxed separately.

With Horizontal Bolt.

Front. No. 381

No. 25/B1323b/608 each 10/-

Rear, Gent.'s No. 382.

No. 25/B1323e/700 each 11/-

Rear, Ladies' No. 383

No. 25/B1323m/704 each 10/6

With Vertical Bolt.

No. 25/B1323r/701

No. 25/B1323s/705

Rear, Gent.'s No. 382 each 10/7

Rear, Ladies' No. 383 11/1

WEBB "SPORTS" CALIPER BRAKES

Alloy and chromium plated steel parts where necessary, adjustable arches, horizontal bolt fitting, with waterproof covered silver cables. Boxed separately.

With curved hooded levers for racing.

No. 25/B1324b/900 Front, No. 281 each 13/6

25/B1324e/905 Rear, Gent.'s No. 282 14/2

25/B1324m/908 Rear, Ladies' No. 283 14/6

With straight hooded lever for touring.

No. 25/B1325b/900 Front, No. 271 each 13/6

25/B1325e/905 Rear, Gent.'s No. 272 14/2

25/B1325m/908 Rear, Ladies' No. 273 14/6

"MONITOR SHEERLINE" CALIPER BRAKES

Chromium plated and polished with silver covered outer cable. Stirrup with horizontal bolt fitting. Sheerline model allows for approximately $\frac{1}{4}$ " adjustment of brake pads up or down, domed nuts fitted to shoes and "Plexax" brake pads, stabilizers being an integral part of shoes.

Front (weight 13 oz.)

No. 25/B1354p/704 .. each 11/-

Rear, Gent.'s (weight 14 oz.)

No. 25/B1354r/706 .. each 11/6

Rear, Ladies' (weight 14 oz.)

No. 25/B1354s/708 .. each 11/6



PRICES shown do NOT include PURCHASE TAX which will be charged at current rates where applicable

Branches
Aberdeen, Ayles, Belfast
Birmingham, Southampton
Bristol, Cardiff, Carlisle
Croydon, Dublin, Dundee
Exeter, Glasgow
Hull, Ipswich, Leeds

Head Office and Warehouse, Wholesale only:

GREAT EASTERN STREET, LONDON, E.C.2

126 GEORGE STREET EDINBURGH, 2

Branches
Liverpool, Manchester
Newcastle-upon-Tyne
Nottingham, Oxford, Preston
Reading, Southampton
Sheffield, Tynes
Wolverhampton

BRAKES (Cable Models)—SIDE and CENTRE PULL—continued

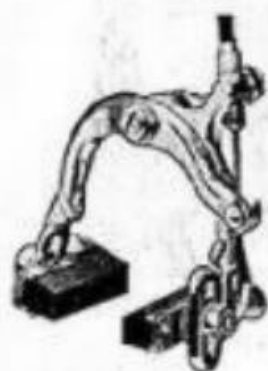

No. 11 Lever.

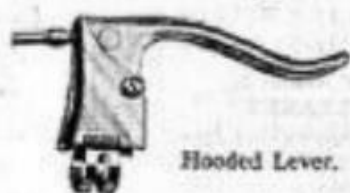

Hooded Lever.

**PHILLIPS "VOX POPULI" SIDE PULL CALIPER
CABLE BRAKES**
Chromium Plated.

Rear Brakes fitted with Stabilisers.

With Black or Silver Waterproof Covered Cable, bolt fitting. Fitted with No. 11 Pattern Lever.

No. 25/B1360b/605	Front (No. 400)	each 9/7
25/B1360c/608	Rear, Gent.'s (No. 401)	10/-
25/B1360m/608	Rear, Ladies' (No. 402)	10/-

Fitted with Special Design Hooded Levers.

No. 25/B1360p/800	Front (No. 400H)	each 12/-
25/B1360r/803	Rear, Gent.'s (No. 401H)	12/4
25/B1360s/803	Rear, Ladies' (No. 402H)	12/4

PHILLIPS "PHILGO" CALIPER CABLE BRAKES
Chromium Plated.

With uncovered Black Enamelled Outer Wire. With No. 11 Pattern Lever. To suit Westwood, 1" Flat Lindrick or Wood Rims.

Front, for Gent.'s or Ladies' Machines. No. 115.

No. 25/B1363b/800	each 9/-
-------------------	-------	-------	----------

Rear, for Gent.'s Machines. No. 116.

No. 25/B1363c/602	each 9/4
-------------------	-------	-------	----------

Rear, for Ladies' Machines. No. 116.

No. 25/B1363m/603	each 9/4
-------------------	-------	-------	----------

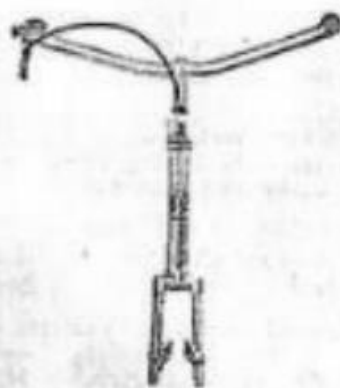
PHILLIPS "WESTWOOD" CABLE BRAKES
Chromium Plated.

Front Brake fitted with "D" Fork Clips.

No. 25/B1366b/704	No. 405	each 11/-
-------------------	---------	-------	-----------

Rear brake fitted with back plates, pin and nut suitable for fitting to any type of seat stays and 1/4" "D" stay clips.

No. 25/B1366c/706	No. 410	each 11/3
-------------------	---------	-------	-----------

**PHILLIPS "PHILITE" LIGHTWEIGHT CALIPER
BRAKES**

Polished Alloy.

With Silver Waterproof Covered Cable, bolt fitting, side pull. Fitted with No. 9 Hooded Lever.

No. 25/B1368b/1103	No. 406	each 16/10
25/B1368c/1111	No. 407	17/11
25/B1368m/1111	No. 408	17/11

FOR COMPLETE RANGE OF VINDEC BRAKE CABLES
see pages 20-21.

PRICES shown do NOT include PURCHASE TAX which will be charged at current rates where applicable

Branches
Aberdeen, Arona, Belfast
Birmingham, Birmingham
Bristol, Cardiff, Cork, Dublin
Croydon, Glasgow, London
Manchester, Newcastle
Newcastle, Nottingham, Perth
Plymouth, Reading, Southampton
Sheffield, Stockport, Tyneside
Wolverhampton

Head Office and Warehouse, Wholesale only:

GREAT EASTERN STREET, LONDON, E.C.2

124 GEORGE STREET, EDINBURGH, 2

Branches
Aberdeen, Arona, Belfast
Birmingham, Birmingham
Bristol, Cardiff, Cork, Dublin
Croydon, Glasgow, London
Manchester, Newcastle
Newcastle, Nottingham, Perth
Plymouth, Reading, Southampton
Sheffield, Stockport, Tyneside
Wolverhampton

BRAKES (Cable Models)—SIDE and CENTRE PULL—continued



"RESILION" CALIPER CABLE BRAKES. FRONT

With Two-screw Clip Fitting.

No.	To fit $\frac{1}{2}$ " Round Forks.	each
25/B1375x/2008	Chromium Plated	27/6
25/B1375z/1611	All Black	22/6
No.	To fit 1" Round Forks.	each
25/B1376b/2008	Chromium Plated	27/6
No.	To fit $\frac{1}{2}$ " "D" Forks.	each
25/B1377ab/2603	All Alloy	35/-
25/B1377b/2008	Chromium Plated	27/6
No.	Chromium Plated with Alloy Lever.	each
25/B1377ba/2206		30/-
25/B1377c/1611	All Black	22/6

For Tandem.

With Two-screw Clip Fitting, fitted with Heavy Clutch Main Cable. Chromium.

To fit $\frac{1}{2}$ " "D" Forks.

No. 25/B1379b/2206 .. each 27/6



"WEINMANN" ALLOY CALIPER BRAKES

Light alloy with highly polished superior finish. Silver waterproof covered cable. Centre bolt fitted with brake shoes adjustable for 26" or 27" rims. Hooded race levers and clip suitable for $\frac{1}{2}$ " or $\frac{3}{8}$ " handlebars.

Weight 19 oz. per pair.

Made in Switzerland.

No. 25/B1460a/1406 Front .. each 21/9
25/B1460b/1406 Gent.'s 21/9



"RESILION" NEW MODEL "GANTILETTE" BRAKES

With Waterproof Covered Silver Outer Cable. Two-screw Clip Fitting. All Chromium Plated with Silver Cables.

Front for $\frac{1}{2}$ " "D" forks.

No. 25/B1389a/1301j each 17/6

Rear, Gent.'s for $\frac{1}{2}$ " or $\frac{1}{4}$ " round.

No. 25/B1389c/1301j each 17/6

Rear, Ladies' for $\frac{1}{2}$ " or $\frac{1}{4}$ " round.

No. 25/B1389e/1301j each 17/6

See page 27 for "RESILION" LEVERS ONLY

Note: "Resilion" Rear Brakes to fit $\frac{1}{2}$ " Pencil chain stays can be obtained specially.



"ALP" LIGHT ALLOY POLISHED SIDE PULL CALIPER BRAKES

With horizontal bolt fitting through crown or top back stay bridge, silver waterproof covered cables, curved levers with hooded clip. Fitted with "La Vipro" brake blocks with rounded studs, giving very much more braking power in wet weather. A thumb wing nut/adjuster for quick adjustment when removing wheel, also acts as a lock on the rim as a theft deterrent. Continental make.

No. 25/B1438a/1200 each 19/6

25/B1438b/1300 19/6



"RESILION" CALIPER CABLE BRAKES. REAR

With Two-screw Clip Fitting.

To fit $\frac{1}{2}$ " Round Back Stays.

No.	Gent.'s.	each
25/B1376aa/2603	All Alloy	35/-
25/B1376e/2008	Chromium	27/6
25/B1376f/1611	All Black	22/6

To fit $\frac{1}{2}$ " Round Back Stays.

No.	Gent.'s.	each
25/B1376p/2008	Chromium	27/6
25/B1376pa/2206	Ditto with Alloy Lever.	30/-
25/B1376pe/2603	All Alloy	35/-
25/B1376r/1611	All Black	22/6

Ladies'

25/B1376t/2008 Chromium .. 27/6

To fit $\frac{1}{2}$ " or $\frac{1}{4}$ " "D" Back Stays.

No. 25/B1377e/2008 Chromium .. 27/6

For Tandems.

With Two-screw Clip Fitting, fitted with heavy clutch main cable.

To fit $\frac{1}{2}$ " Round Back Stays.

No. 25/B1379e/2206 Two Gent.'s Tandem Chromium .. each 30/-

For Gent.'s and Rear Ladies' Tandem.

No. 25/B1379h/2206 Chromium Plated .. each 30/-



CYCLE LOCKS FOR "RESILION" BRAKES

"Resilion" Brakes can be supplied with Alloy Lever fitted with Cycle Lock and two yale pattern keys.

-503 Extra charge .. per brake 7/-

PRICES shown do NOT include PURCHASE TAX which will be charged at current rates where applicable

Branches
Aberdeen, Ayles, Belfast
Birmingham, Bournemouth
Bristol, Cardiff, Colchester
Croydon, Dublin, Dundee
Leamington, Glasgow
Newcastle, Leeds

Head Office and Warehouse, Wholesale only:

GREAT EASTERN STREET, LONDON, E.C.2

126 GEORGE STREET EDINBURGH, 2

Branches
Sheffield, Manchester
Newcastle upon Tyne
Nottingham, Oxford, Preston
Reading, Southampton
Tottenham, Watlington

BRAKES (Pull-up Lever Models)—continued

FRONT BRAKES, with Pull-up Lever and $\frac{1}{4}$ " Clip.

PHILLIPS "QUICKFIT"

Short lever. Handlebar stem fitting (No. 4).
Chromium Plated.
No. 25/B2006L/409 each 7/1



PHILLIPS "QUICKFIT"

Long Lever. Handlebar stem fitting (No. 2).
Chromium Plated.
No. 25/B2006b/409 each 7/1



PHILLIPS "QUICKFIT"

Short Lever. Handlebar stem fitting (No. 6).
Chromium Plated.
No. 25/B2006w/409 each 7/1



PHILLIPS "PHILCO" FRONT PULL-UP CALIPER ACTION BRAKES.

Central Pull.

With Short Cranked Lever and $\frac{1}{4}$ " Clip (No. 351).
Suitable for "Endrick" Rims.



Chromium Plated.

No. 25/B2008L/605 each 9/7

PHILLIPS FRONT JUVENILE PLUNGER TYPE

For Cushion-tyred Toy Cycles.
To bolt on Flat Handlebar.
For "Faircycles."
Chromium Plated.

Brake complete (No. 12).

No. 25/B2045c/209 each 5/7



PHILLIPS "QUICKFIT" ROADSTER REAR BRAKES

With Pull-up Short Lever, $\frac{1}{4}$ " stem fitting clip, and clip-fitting Bell Crank. Chromium Plated (No. 9).

No. 25/B2070L/605 each 9/7



PHILLIPS "CREDEX" BAR FITTING PULL-UP LEVER BRAKES

Less Handlebar.

Chromium Plated.

Front (No. 27).

No. 25/B2071a/409 each 7/1

Rear (No. 28).

No. 25/B2072c/605 each 9/7

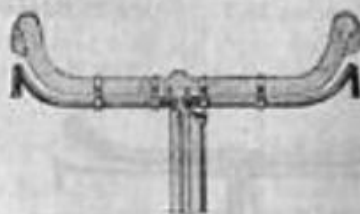

PHILLIPS "COSMOS" ROLLER LEVER BRAKE

Band Clip Fitting Roller Levers.
Less Handlebar.

With Round Peg Guides. To suit 18" x $\frac{1}{4}$ " dia. For Ordinary Raised Handlebar.

Front (No. 18).

Chromium Plated.

No. 25/B2100b/500 each 7/6

Rear (No. 19).

Chromium Plated.

No. 25/B2330b/610 per set 10/3



CATO FRONT BRAKE BOTTOM PARTS

Comprising brake tube with eye bolt, stirrups, shoes and pads and fork clips.

Chromium Plated. each

No. 25/B2290h/308 .. For Standard 5/6

No. 25/B2290m/308 Juvenile 5/6

PRICES shown do NOT include PURCHASE TAX which will be charged at current rates where applicable

Branches
Aberdeen, Ayles, Belfast
Birmingham, Birmingham
Bristol, Cardiff, Cardiff
Cardiff, Dublin, Dundee
Edinburgh, Glasgow
Preston, London

Head Office and Warehouse, Wholesale only

GREAT EASTERN STREET, LONDON, E.C.2

134 GEORGE STREET EDINBURGH 3

Branches
Liverpool, Manchester
Newcastle-upon-Tyne
Nottingham, Oxford, Preston
Reading, Southampton
Sheffield, Truro
Wolverhampton

BRAKES (Roller Lever Models)—continued
FRONT AND REAR (Combined).



PHILLIPS "CELTONIA" BRAKES. ORDINARY RAISED

Front and Rear Brakes complete with bottom parts. Fitted with Roller Levers on 18" wide Handlebars.
Rear on left. With expander belt.
Chromium Plated.

No. 25/B2412d/2002	per set 30/3
Handlebars and Brakes only (Less bottom parts).		
No. 25/B2412r/1409	per set 22/1

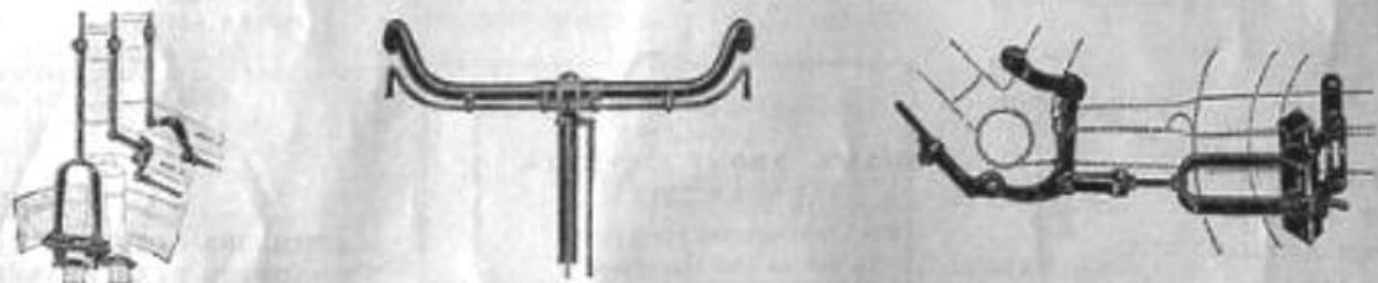

PHILLIPS CARRIER CYCLE BRAKE SETS

WITH HEAVY GAUGE ORDINARY HIGH RAISED BENDS 18" WIDE AND STEMS 8" LONG WITH STUD LUGS.
Extra Long Stirrups and large-size Carrier Brake Blocks.

FRONT AND REAR BRAKES

Fitted with Roller Levers on Handlebar.
Clip (A) Fitting Bell Crank.

FRONT AND REAR BOTTOM PARTS ONLY

Clip (A) Fitting Bell Crank.

No. 25/B2455e/2209	All Black	per set 35/7	No. 25/B2457e/904	All Black	per set 14/-
			Bolt (D) Fitting Bell Crank	All Black	per set 14/-

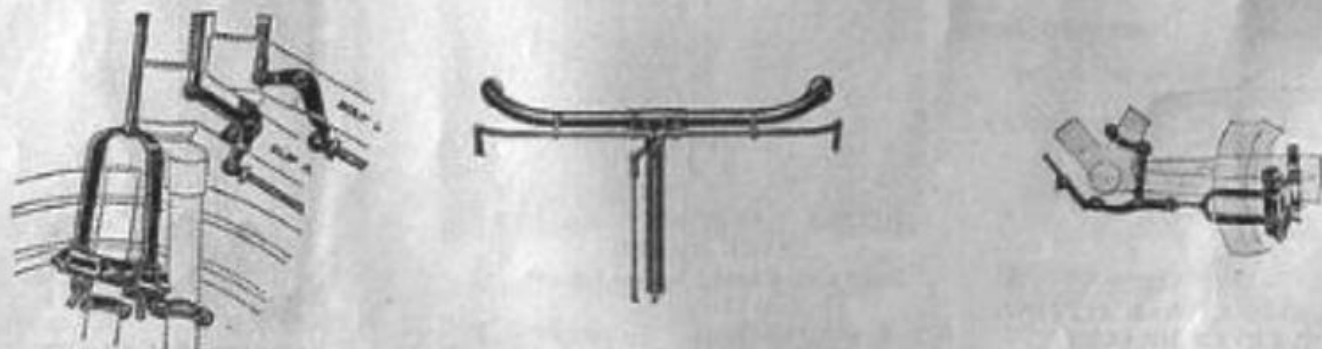

PHILLIPS EXTRA HEAVY CARRIER CYCLE BRAKE SETS

WITH HEAVY GAUGE ORDINARY HIGH RAISED BENDS 18" WIDE AND STEMS 8" LONG WITH STUD LUGS.
Extra Heavy Long Stirrups and large-size Carrier Brake Blocks.

FRONT AND REAR BRAKES, fitted with Roller Levers on Handlebar and 19" long Brake Tubes. Bolt Fitting Bell Crank.
Specially Suitable for SMALL FRONT WHEEL LOW-GRAVITY CARRIER CYCLES.

No. 25/B2462e/2407	All Black	per set 36/10
--------------------	-------------------	---------------

PRICES shown do NOT include PURCHASE TAX which will be charged at current rates where applicable

Branches:
Aberdeen, Ayr, Belfast
Birmingham, Blackburn
Bristol, Cardiff, Carlisle
Croydon, Dublin, Dundee
Leamington, Glasgow
Preston, Liverpool, Leeds

Head Office and Warehouse, Wholesale only:

GREAT EASTERN STREET, LONDON, E.C.2

126 GEORGE STREET EDINBURGH, 2

Branches:
Liverpool, Manchester
Newcastle-upon-Tyne
Nottingham, Oxford, Preston
Reading, Southampton
Sheffield, Tynes
Wolverhampton

BRAKES (Roller Lever Models)—continued

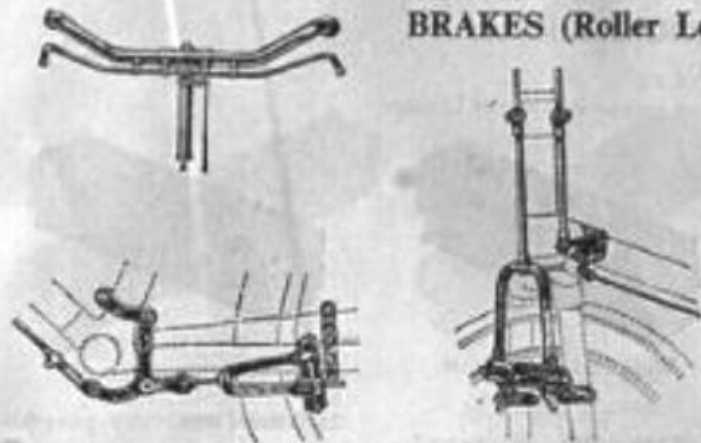

PHILLIPS "CELTONIA" JUVENILE NORTH ROAD RAISED HANDLEBARS

Complete with front and rear Roller Lever Brakes. 14½" wide with ½" dia. stem, 1" frame tube clips, ½" "D" fork and stay clips.

Fitted with expander bolt.

Chromium Plated.

No. 25/B2569c/2005 per set 30/7

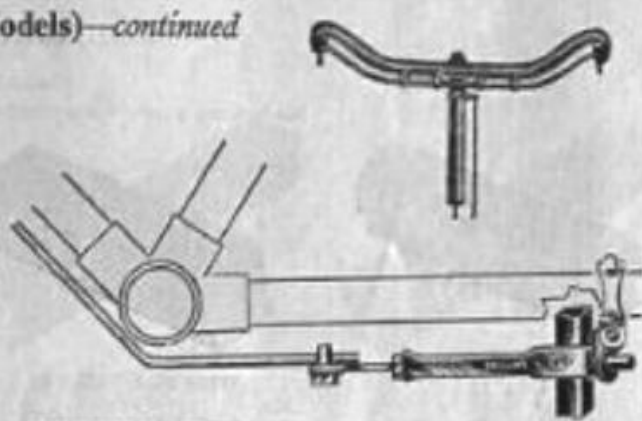

PHILLIPS "PHILCO" JUNIOR FRONT AND REAR BRAKES

Fitted with Roller Levers on ½" dia. Handlebar. 16" wide. ½" stem fitted with expander bolt. For 5" heads with ½" bell crank lever clip, ½" "D" fork clips, with rear down rod under bracket to stirrup. Round peg guides. Chromium Plated.

North Road Raised.

No. 25/B2596d/1704 per set 26/-

As above with Front Brake only.

No. 25/B2596a/1209 per set 19/1

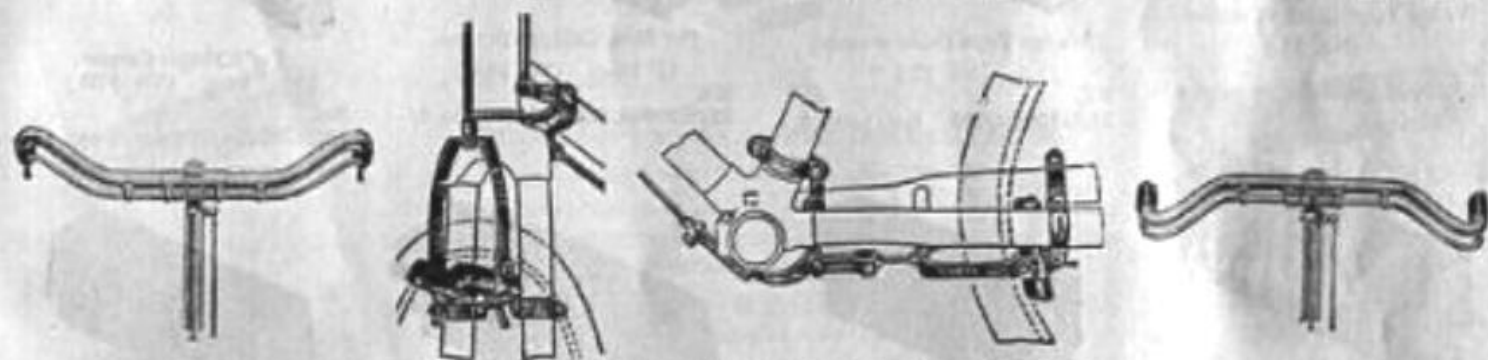

PHILLIPS "CELTONIA" FRONT AND REAR BRAKES

18" North Road Raised.

Front and Rear Brakes. Complete with Bottom Parts. Fitted with Roller Levers on Handlebar. (With Rear Lever on Left-hand side.)

Complete with expander bolt.

Chromium Plated.

No. 25/B2710d/2008 per set 31/-

Handlebars and Brakes only (less Brake Bottom Parts).

No. 25/B2710r/1503 per set 22/10

18" North Road Dropped

Front and Rear Brakes. Complete with Bottom Parts. Fitted with Roller Levers on Handlebar. Complete with expander bolt.

Fitted with Rear Lever on Left-hand side.

Chromium Plated.

No. 25/B2808d/2008 per set 31/-

Handlebars and Brakes only (less Brake Bottom Parts.)

No. 25/B2808r/1503 per set 22/10

"PHILLIPS" FRONT AND REAR BOTTOM PARTS ONLY.

For "Celtonia"

Bolt fitting Bell Crank Clip and Rod for Left-hand side.

No. 25/B2885b/706 Chromium Plated per set 11/3

For "Philco" Kiddies

With Bell Crank Clip and Rod for Left-hand side.

No. 25/B2885e/703 Chromium Plated per set 10/10

For Low Gravity Carrier.

With Bolt fitting Bell and Crank Rod for Left-hand side.

No. 25/B2885c/1002 Black Enamelled per set 15/3



Illustration shows "Philco" pattern. No. 25/B2885e.

PRICES shown do NOT include PURCHASE TAX which will be charged at current rates where applicable

Branches
Aberdeen, Arson, Belfast
Birmingham, Bournemouth
Bristol, Cardiff, Carlisle
Croydon, Dublin, Dundee
Exeter, Glasgow
Hull, Ipswich, Leeds

Head Office and Warehouse, Whitechapel only.

GREAT EASTERN STREET, LONDON, E.C.2

136 GEORGE STREET EDINBURGH, 3

Branches
Liverpool, Manchester
Newcastle-upon-Tyne
Nottingham, Oxford, Preston
Reading, Southampton
Sheffield, Tyneside
Wolverhampton

BRAKE BLOCKS

FERODO

Made from a new waterproof material and packed in boxes of 12 pairs.



Wide Section.
(No. 33.)

No. 25/B3006b/600 doz. pairs 9/-



Wide Flat. (No. 96.)

No. 25/B3006d/600 doz. pairs 9/-



Wide Flat for Endrick.
(No. 102.)

No. 25/B3006e/600 doz. pairs 9/-



Wide Section.
(No. 51A.)

No. 25/B3006f/600 doz. pairs 9/-



Wedge Type (narrow section).
(No. 53.)

No. 25/B3006g/600 doz. pairs 9/-



Wedge Type (wide section)
(No. 52.)

No. 25/B3006h/600 doz. pairs 9/-



For Rear Calliper Brakes,
1 1/2" long. (No. 16A.)

No. 25/B3006k/600 doz. pairs 9/-



For Raleigh Carrier,
2 1/4" long. (No. 57B.)

No. 25/B3006m/704 doz. pairs 11/-



For Allday's and Warwick
Carrier Tricycles. Flat Top.
(No. 63.)

No. 25/B3006p/600 doz. pairs 9/-



For Raleigh and Phillips (Yoke
hinge) 1 1/2" long.
(No. 57A.)

No. 25/B3006r/600 doz. pairs 9/-

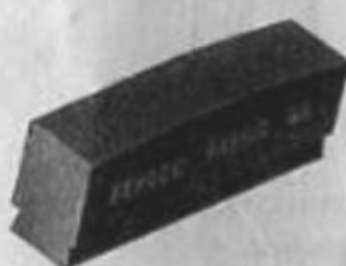

For Hercules, New Hudson and
Phillips Carrier Cycles, large
deep pattern, 2 1/4" long.
(No. 66.)

No. 25/B3006s/800 doz. pairs 12/-



For Phillips' Sellwell, Caliper, 1 1/2"
long. Flat Top, wedge pattern.
(No. 92B.)

No. 25/B3006w/600 doz. pairs 9/-



For Warwick Carrier Cycle, large
deep pattern, 2 1/4" long.
(No. 85.)

No. 25/B3006t/904 doz. pairs 14/-



For Caliper Brakes. Soft for
Alloy Rims. (No. 109.)

No. 25/B3006x/600 doz. pairs 9/-

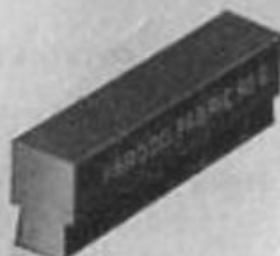

Raleigh Caliper. (No. 98B.)

No. 25/3007a/600 doz. pairs 9/-



Resilicon Standard.
3" long by 1" deep. (No. 95A.)

No. 25/B3007l/704 doz. pairs 11/-

PRICES shown do NOT include PURCHASE TAX which will be charged at current rates where applicable

Branches:
Aberdeen, Aston, Belfast,
Birmingham, Bournemouth,
Bristol, Cardiff, Cardiff,
Croydon, Dublin, Dundee,
Leeds, London, Glasgow,
Newcastle, Leeds

Head Office and Warehouse, Wholesale only:

GREAT EASTERN STREET, LONDON, E.C.2

124 GEORGE STREET EDINBURGH, 1

Branches:
Liverpool, Manchester,
Newcastle-upon-Tyne,
Nottingham, Oxford, Preston,
Reading, Southampton,
Leeds-on-Trent,
Wolverhampton

BRAKE BLOCKS—continued

FERODO—continued



Resilion Tandem Cantilever.
3" long × 1/2" deep.
(No. 93B.)

No. doz. pairs
25/B3007m/704 .. 11/-



Resilion Cantilette.
2 1/4" long × 1/2" deep
(No. 95D.)

No. doz. pairs
25/B3007p/600 .. 9/-



Resilion Cantilever.
(Shallow.)
3" long × 3/8" deep.
(No. 95E.)

No. doz. pairs
25/B3007r/704 .. 11/-



Resilion Cantilette.
(Shallow.)
2 1/4" long × 3/8" deep.
(No. 95F.)

No. doz. pairs
25/B3007s/600 .. 9/-

FIBRAX BRAKE BLOCKS



Packed in cardboard cartons
of 1 doz. pair.



Flat Top. Wide Section. (No. 3.)
No.
25/B3009c/504 doz. pairs 8/-



No. Narrow Section. (No. 51.)
25/B3009m/504 doz. pairs 8/-



For Ridge-Whitworth.
No. 2 1/2" long. (No. 71.)
25/B3009p/608 doz. pairs 10/-

No. 2 1/4" long. (No. 71/2.)
25/B3009pp/504 doz. pairs 8/-



No. For B.S.A. (No. 106.)
25/B3009t/504 doz. pairs 8/-

FIBRAX SOFT RED CALIPER BRAKE BLOCKS

Specially made for use with alloy Rims.

This new material has been specially produced to save alloy rims from excessive wear and is confidently offered after long periods of testing in the laboratory and on the road.

The smooth and certain action of the brake blocks prolongs the life of Block and Rim. All popular caliper patterns available.

No.	Pattern No.	Make.	Doz. pairs
25/B3008d/600	245	For Raleigh Road Race ..	9/-
25/B3008e/600	250	.. Webb	9/-
25/B3008f/600	253	.. Resilion Tandem, 3" long	12/-
25/B3008g/600	260 Front or Rear, 1 1/2" long	9/-
25/B3008h/600	260 " " " " " 2 1/4" "	9/-
25/B3008i/600	260 " " " " " 3" "	12/-
25/B3008r/600	269	.. G.B., Barlita, Monitor or Phillips	9/-
25/B3008s/600	275	.. B.S.A.	9/-



No. Round Top. (No. 21.)
25/B3009h/504 doz. pairs 8/-



For Raleigh, York and Hinge
No. (No. 70.)
25/B3009n/504 doz. pairs 8/-
For Raleigh Carrier. (No. 70/2.)
No.
25/B3009nc/608 doz. pairs 10/-



For Caliper Brakes. (No. 105.)
No.
25/B3009s/504 doz. pairs 8/-



For Doherty, Phillips', Vox
Populi, Celtonia. (No. 258.)

No.
25/B3009u/504 doz. pairs 8/-



For Bowden and Vindec Carrier
Cycle Brakes. (No. 130.)

No.
25/B3009w/608 doz. pairs 13/-



For Sunbeam Front, old and new
pattern. Also for Rear, 1938 on.

No. (No. 257.)
25/B3009x/608 doz. pairs 13/-

PRICES shown do NOT include PURCHASE TAX which will be charged at current rates where applicable

Branches
Aberdeen, Arrol, Belfast
Birmingham, Southampton
Bristol, Cardiff, Cardiff
Croydon, Dublin, Dundee
Exeter, Glasgow
Hull, Ipswich, Leeds

Head Office and Warehouse, Wholesale only

GREAT EASTERN STREET, LONDON, E.C.2

120 GEORGE STREET EDINBURGH, 2

Branches
Liverpool, Manchester
Newcastle-upon-Tyne
Nottingham, Oxford, Preston
Reading, Southampton
Sheffield, Wakefield

BRAKE CABLES COMPLETE

**VINDEC**

Best Quality.

Combined waterproof (woven) covered outer cable and non-fray inner wire and nipples.

Made up complete ready for fitting to the following brakes.

Each cable packed in a separate single carton printed "Vindex," showing our list number, and the type of brake for which it is suitable.



For Webb New Pattern.

No. 25/B3042d/100	Silver	Front each	1/6
25/B3042e/105		Rear, Gent.'s "	2/1
25/B3042f/107		" Ladies' "	2/4



For "Webb"

No. 25/B3042g/101	Black	Front each	1/7
25/B3042h/105		" ..	per doz.	—
25/B3042i/106		Rear, Gent.'s each	2/2
25/B3042j/106	Silver	" ..	per doz.	—
25/B3042k/107		Rear, Ladies' each	2/5
25/B3042l/107		" ..	per doz.	—
25/B3042m/1206	Black	Front each	1/7
25/B3042n/1206		" ..	per doz.	—
25/B3042o/105		Rear, Gent.'s each	2/2
25/B3042p/105	Silver	" ..	per doz.	—
25/B3042q/106		Rear, Ladies' each	2/5
25/B3042r/106		" ..	per doz.	—



For "Monitor" Super Cam.

No. 25/B3042s/104	Black	Front each	2/-
25/B3042t/106		" ..	per doz.	—
25/B3042u/109		Rear, Gent.'s each	2/7
25/B3042v/2006	Silver	" ..	per doz.	—
25/B3042w/106		Rear, Ladies' each	2/3
25/B3042x/1706		" ..	per doz.	—
25/B3042y/104	Black	Front each	2/-
25/B3042z/1506		" ..	per doz.	—
25/B3042aa/109		Rear, Gent.'s each	2/7
25/B3042ab/2006	Silver	" ..	per doz.	—
25/B3042ac/2006		Rear, Ladies' each	2/3
25/B3042ad/106		" ..	per doz.	—



For "Burlite."

No. 25/B3034a/11	Silver	Front each	1/5
25/B3034b/103		Rear, Gent.'s "	1/10



For "Monitor" Climax Old Pattern.

No. 25/B3042L/10	Black	Front each	1/2
25/B3042L/906		" ..	per doz.	—
25/B3042m/102		Rear, Gent.'s each	1/9
25/B3042n/104	Silver	" ..	per doz.	—
25/B3042o/1506		Rear, Ladies' each	2/-
25/B3042p/10		" ..	per doz.	—
25/B3042q/906	Black	Front each	1/2
25/B3042r/102		" ..	per doz.	—
25/B3042s/1306		Rear, Gent.'s each	1/9
25/B3042t/104	Silver	" ..	per doz.	—
25/B3042u/1506		Rear, Ladies' each	2/-
25/B3042v/1506		" ..	per doz.	—

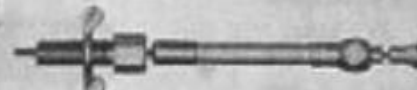

For "Monitor" Sheerline New Pattern.

No. 25/B3042nf/9	Silver	Front each	1/1
25/B3042ng/806		" ..	per doz.	—
25/B3042nh/101		Rear, Gent.'s each	1/7
25/B3042ni/1206	Black	" ..	per doz.	—
25/B3042nj/105		Rear, Ladies' each	2/2
25/B3042nk/1606		" ..	per doz.	—



For "B.S.A." New Pattern.

No. 25/B3043p/101	Silver	Front each	1/8
25/B3043q/2006		" ..	per doz.	—
25/B3043r/106		Rear, Gent.'s each	2/3
25/B3043s/1706	Black	" ..	per doz.	—
25/B3043t/109		Rear, Ladies' each	2/7
25/B3043u/2006		" ..	per doz.	—



For "B.S.A." Old Pattern.

No. 25/B3043l/101	Black	Front each	1/8
25/B3043m/1206		" ..	per doz.	—
25/B3043n/106		Rear, Gent.'s each	2/3
25/B3043o/1706	Silver	" ..	per doz.	—
25/B3043p/109		Rear, Ladies' each	2/7
25/B3043q/2006		" ..	per doz.	—
25/B3043r/101	Black	Front each	1/8
25/B3043s/1206		" ..	per doz.	—
25/B3043t/106		Rear, Gent.'s each	2/3
25/B3043u/1706	Silver	" ..	per doz.	—
25/B3043v/109		Rear, Ladies' each	2/7
25/B3043w/2006		" ..	per doz.	—

PRICES shown do NOT include PURCHASE TAX which will be charged at current rates where applicable

Branches
Aberdeen, Ayles, Belfast
Birmingham, Bournemouth
Bristol, Cardiff, Carlisle
Croydon, Dublin, Dundee
Exeter, Glasgow
Hull, Liverpool, Leeds

Head Office and Warehouse, Wholesale only:

GREAT EASTERN STREET, LONDON, E.C. 2

114 GEORGE STREET EDINBURGH 1

Branches
Liverpool, Manchester
Newcastle-upon-Tyne
Nottingham, Oxford, Preston
Reading, Southampton
Sheffield, Telford
Wolverhampton

BRAKE CABLES COMPLETE—continued

VINDEC—continued



For "G.B."

No. 25/B3045p/102	Silver	Front	each	1/9
25/B3045p/1306			per doz.	—
25/B3045r/107		Rear	each	2/5
25/B3045r/1806			per doz.	—



For Phillips "Vox Populi."

No. 25/B3045t/102	Black	Front	each	1/9
25/B3045t/1306			per doz.	—
25/B3045w/107		Rear, Gent.'s	each	2/4
25/B3045w/1806			per doz.	—
25/B3045x/109	Rear, Ladies'	each	2/7	
25/B3045x/2006		per doz.	—	
25/B3045ts/102	Silver	Front	each	1/9
25/B3045ts/1306			per doz.	—
25/B3045ws/107		Rear, Gent.'s	each	2/4
25/B3045ws/1806			per doz.	—
25/B3045xs/109	Rear, Ladies'	each	2/7	
25/B3045xs/2006		per doz.	—	



For Doherty Model "C" and "E" New Pattern.

No. 25/B3046p/9	Silver	Front	each	1/2
25/B3046p/806			per doz.	—
25/B3046r/102		Rear, Gent.'s	each	1/9
25/B3046r/1306			per doz.	—
25/B3046s/104	Rear, Ladies'	each	2/-	
25/B3046s/1506		per doz.	—	



For Doherty Model C Old Pattern.

No. 25/B3046t/101	Silver	Front	each	1/8
25/B3046t/1206			per doz.	—
25/B3046w/105		Rear, Gent.'s	each	2/2
25/B3046w/1806			per doz.	—
25/B3046x/108	Rear, Ladies'	each	2/6	
25/B3046x/1906		per doz.	—	



For "Raleigh"

No. 25/B3044a/106	Black	Front	each	2/3
25/B3044a/1706			per doz.	—
25/B3044b/110		Rear, Gent.'s	each	2/9
25/B3044b/2106			per doz.	—
25/B3044c/200	Rear, Ladies'	each	3/-	
25/B3044c/2206		per doz.	—	
25/B3044as/106	Silver	Front	each	2/3
25/B3044as/1706			per doz.	—
25/B3044bs/110		Rear, Gent.'s	each	2/9
25/B3044bs/2106			per doz.	—
25/B3044cs/200	Rear, Ladies'	each	3/-	
25/B3044cs/2306		per doz.	—	



For Hercules.

No. 25/B3044g/103	Black	Front	each	1/11
25/B3044g/1406			per doz.	—
25/B3044h/108		Rear, Gent.'s	each	2/6
25/B3044h/1906			per doz.	—
25/B3044k/110	Rear, Ladies'	each	2/9	
25/B3044k/2106		per doz.	—	
25/B3044gs/103	Silver	Front	each	1/11
25/B3044gs/1406			per doz.	—
25/B3044hs/108		Rear, Gent.'s	each	2/6
25/B3044hs/1906			per doz.	—
25/B3044ks/110	Rear, Ladies'	each	2/9	
25/B3044ks/2106		per doz.	—	

For "Hercules" New 1950 Pattern.

No. 25/B3044ts/103	Silver	Front	each	1/11
25/B3044ts/1406			per doz.	—
25/B3044ws/107		Rear, Gent.'s	each	2/5
25/B3044ws/1806			per doz.	—
25/B3044xs/110	Rear, Ladies'	each	2/9	
25/B3044xs/2106		per doz.	—	



For Standard Central Pull.

No. 25/B3046a/101	Black	Front	each	1/7
25/B3046a/1206			per doz.	—
25/B3046b/105		Rear, Gent.'s	each	2/1
25/B3046b/1606			per doz.	—
25/B3046c/107	Rear, Ladies'	each	2/5	
25/B3046c/1806		per doz.	—	
25/B3046as/101	Silver	Front	each	1/7
25/B3046as/1206			per doz.	—
25/B3046bs/105		Rear, Gent.'s	each	2/1
25/B3046bs/1606			per doz.	—
25/B3046cs/107	Rear, Ladies'	each	2/5	
25/B3046cs/1806		per doz.	—	



For Standard Side Pull.

No. 25/B3046d/103	Black	Front	each	1/11
25/B3046d/1406			per doz.	—
25/B3046e/107		Rear, Gent.'s	each	2/5
25/B3046e/1806			per doz.	—
25/B3046f/110	Rear, Ladies'	each	2/9	
25/B3046f/2106		per doz.	—	
25/B3046ds/103	Silver	Front	each	1/11
25/B3046ds/1406			per doz.	—
25/B3046es/107		Rear, Gent.'s	each	2/5
25/B3046es/1806			per doz.	—
25/B3046fs/110	Rear, Ladies'	each	2/9	
25/B3046fs/2106		per doz.	—	

PRICES shown do NOT include PURCHASE TAX which will be charged at current rates where applicable

Branches
Aberdeen, Ayles, Belfast
Birmingham, Southampton
Bristol, Cardiff, Cardiff
Croydon, Dublin, Dundee
Exeter, Glasgow
Hull, Liverpool, Leeds

Head Office and Warehouse, Wholesale only

GREAT EASTERN STREET, LONDON, E.C.2

126 GEORGE STREET, EDINBURGH, 1

Branches
Liverpool, Manchester
Newcastle-upon-Tyne
Nottingham, Oxford, Preston
Reading, Southampton
Sheffield, Wakefield
Wolverhampton

BRAKE CABLES COMPLETE—continued

CABLE CLIPS

SUNDRIES

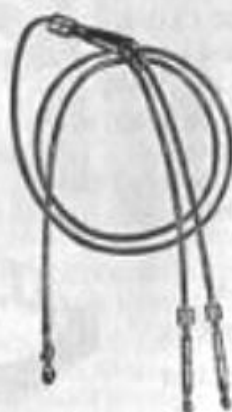
**RESILION
CANTILEVER BRAKE CABLE**
Waterproof covered.

Complete unit with Springs, Junction Box, Adjusters and all Nipples soldered on.

For Front Brakes.

- No. 25/B3047L/500 .. each 7/6
For Rear, Gent's Brakes.
- No. 25/B3047m/508 .. each 8/6
For Rear, Ladies' Brakes.
- No. 25/B3047n/508 .. each 8/6
For Two-Gent's Tandem Brakes.
- No. 25/B3047p/604 .. each 9/6
For Front Tandem Brakes.
- No. 25/B3047r/500 .. each 7/6

**PHILLIPS
BRAKE CABLE CUP NIPPLES**

For Enamelled or Waterproof Casing.
For Phillips' Brakes. No. CB9-4.

- No. 25/B3051c/102 .. per doz. 1/9

BRAKE FERRULES

For Waterproof Covered
Outer Cable.
1 gross assorted in box.

- No. 25/B3051n/800 .. per box 12/-

FRAME CABLE CLIPS

For Cable Brakes.
Black Enamelled.

- No. 25/B3054a/8 .. per doz. -/9
Aluminium.
- No. 25/B3054b/100 .. per doz. 1/6

**RESILION
RECONDITIONED CABLES**
Waterproof Covered for Cantilever
and Cantilette Brakes.

Complete unit with Springs, Junction
Box, Adjusters and all Nipples
soldered on.

For Front.

- No. 25/B3048a/209 .. each 4/6
For Rear, Gent's.
- No. 25/B3048b/209 .. each 4/6
For Rear, Ladies'.
- No. 25/B3048c/209 .. each 4/6
For Front Tandem.
- No. 25/B3048k/209 .. each 4/6
For Two-Gent's Tandem.
- No. 25/B3048l/209 .. each 4/6

Important.

We have now made arrangements with
the Resilion Co. whereby we can ex-
change, from stock, broken or worn
cables for Reconditioned Cable Units
at the above prices.

FERRULES

For Waterproof
Outer Cable. Size No. 1.

- No. 25/B3051g/7 .. per doz. -/10 1/2

**RESILION
BRAKE CABLE NIPPLE BARS**

Black only.

For Model Cantilever Brakes.

1 1/2" long for Front.

- No. 25/B3052f/800 .. per doz. 12/-

1" long for Rear.

- No. 25/B3052g/800 .. per doz. 12/-

**"ALUMLITE" ALLOY TWIN
CABLE CLIPS**

To secure Front and Rear Brake Cables
together, giving a very neat and tidy appear-
ance. Secured by screw and nut.

Polished finish (loose).

- No. 25/B3053p/600 .. per doz. 9/-

Assortment of Polished Anodised and Coloured
(loose).

- No. 25/B3053pr/800 .. per doz. 12/-

On display cards of 2 1/2 dozen. Polished and
assorted Anodised Colours.

- No. 25/B3053a/1800 .. per card 27/-

TACOMA TWIN CABLE CLIPS

Polished alloy, on cards of 16.

- No. 25/B3053b/800 .. per card 12/-

TERRY FERRULES

For Waterproof Outer Cable.
In boxes of 1 Gross assorted.
Sizes Nos. 0, 1 and 2.

- No. 25/B3051k/900 .. per box 13/6

**BRAKE CABLE CUP
NIPPLES**

To fit into Levers, and for end
of outer cable to fit into.

Large size, for waterproof covered.

- No. 25/B3051a/102 .. per doz. 1/9

Small size, for enamelled casing.

- No. 25/B3051b/102 .. per doz. 1/9

Nickel Plated for Raleigh.

- No. 25/B3051r/102 .. per doz. 1/9

**"VINDEC" WATERPROOF OUTER
CABLE ONLY**

In Coils of 50 feet.

Best Quality. No. 1.

- No. 25/B3050c/603 Black each 9/4
- 25/B3050m/603 Silver .. 9/4
- 25/B3050n/607 Red .. 10/-
- 25/B3050p/607 Blue .. 10/-
- 25/B3050r/607 Green .. 10/-
- 25/B3050s/607 Yellow .. 10/-
- 25/B3050t/607 White .. 10/-

Best Quality. No. 2.

- No. 25/B3050w/700 Silver .. each 10/6

Note: No. 2 Outer Cable is suitable for
G.B. Brakes.

**RESILION BRAKE
CASING CLIPS**

For brazing into position on Top
Tube to carry the Brake Wires.

Neat in appearance, permanent, and less
expensive.

- No. 25/B3052t/104 .. per doz. 2/-

**FRAME
CABLE CLIPS**

Spring Steel for
Cable Brakes.

Black Enamelled.

For 1/2" tubes

- No. 25/B3054k/6 .. per doz. -/9



PRICES shown do NOT include PURCHASE TAX which will be charged at current rates where applicable.

Branches
Aberdeen, Ayles, Belfast
Birmingham, Bournemouth
Bristol, Cardiff, Cork, Dublin
Glasgow, London, Newcastle
Newcastle-upon-Tyne, Nottingham, Oxford, Preston
Reading, Southampton
Sheffield, Stockport
Tottenham, Wakefield

Head Office and Warehouses, Wholesale only:

GREAT EASTERN STREET, LONDON, E.C. 2
126 GEORGE STREET EDINBURGH 1

Branches
Liverpool, Manchester
Newcastle-upon-Tyne
Nottingham, Oxford, Preston
Reading, Southampton
Sheffield, Stockport
Tottenham, Wakefield

BRAKE CABLE CLIPS—continued CABLE WIRE

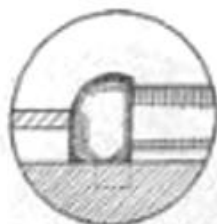

CABLE EYES OR STOPS
To brazing on top tube.

- No. 25/B3052b/206 For Brakes .. per doz. 5/3
 25/B3052d/206 For Gears .. 5/3
 Note: These cable eyes are usually brazed in at each end of top tube.



JOHN BULL RUBBER FRAME CABLE BANDS
For 1", 1", or 1 1/4" tubes.
Black.

- No. 25/B3054w/204 .. per doz. 3/6
 Assorted Colours.
 No. 25/B3054ww/204 .. per doz. 3/6

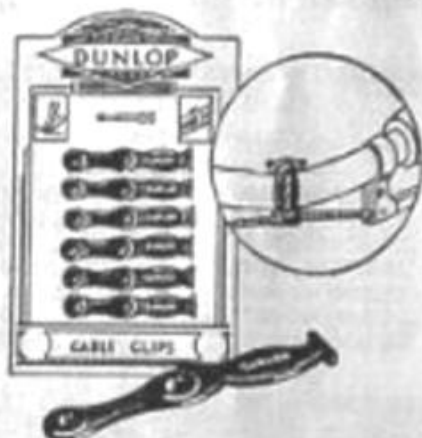

DUNLOP RUBBER FRAME CABLE BANDS

- For 1", 1", or 1 1/4" tubes.
 Packed on Display Cards of 36.
 No. 25/B3054z/700 Black per card 10/6
 In assorted colours.
 On Display Cards of 36.
 No. 25/B3054zz/700 .. per card 10/6



RESILION ADJUSTERS WITH NUTS

- For Junction Box.
 No. 25/B3055k/6 .. each -/9
 25/B3055k/504 .. per doz. —
 For sides of Front Forks or Back Stays (small size).
 No. 25/B3055p/400 .. per doz. 6/-

RESILION FRAME CABLE CLIPS

Spring Steel for Cabin Brakes.
 Chromium Plated.



- No. 25/B3053L/400 For 1" tubes .. per doz. 6/-
 25/B3053m/400 For 1 1/4" tubes .. 6/-

"VINDEG" BLACK RUBBER CABLE BANDS

(Similar to B3054z.)

- No. 25/B3054t/101 .. per doz. 1/7



PHILLIPS CABLE ADJUSTING SCREW AND NUT
With adjusting split nut.

- No. 25/B3055f/603 .. per doz. 9/4



G.B. BRAKE ADJUSTERS

Screw and nut complete.
 Plated.

- No. 25/B3055g/7 .. each -/10 1/2
 25/B3055g/608 .. per doz. —



STRANDED NON-FRAY INNER CABLE WIRES

For Caliper Cable Brakes, complete with 2 nipples (1 Fixed and 1 Loose).

- 1' 10" long. For Front.
 No. 25/B3058g/4 .. each -/6
 25/B3058g/304 .. per doz. —
 3' 9" long. For Rear, Gent.'s.
 No. 25/B3058k/5 .. each -/8
 25/B3058k/400 .. per doz. —
 4' 9" long. For Ladies'.
 No. 25/B3058l/8 .. each -/9
 25/B3058l/506 .. per doz. —

TERRY'S FRAME CABLE CLIPS

Spring Steel for Cable Brakes. For 1" tubes.



- Black Enamelled.
 No. 25/B3054g/102 .. per doz. 1/7
 Chromium Plated.
 No. 25/B3054gc/102 .. per doz. 1/7

CYCLO

CYCLE FRAME CABLE CLIPS



Cadmium Plated half clip, with rubber band to hook on each end of clip, to fit 1" frame tube.

- No. 25/B3054s/200 .. per doz. 3/-

PHILLIPS CABLE CLIPS

(Regd. Design.)



Cadmium Plated.

- No. 25/B3054p/200 .. per doz. 3/-



STRANDED INNER CABLE WIRE

For Cable Cycle Brakes.
 (British make.) Best quality.

Special Non-Fray Quality. In Colls.
 This Wire can be cut without ends fraying, no soldering required before cutting.

- | No. 1 Size. | | Each |
|-----------------|--------|------|
| No. | Length | |
| No. 25/B3059p/8 | 12' | 1/2 |
| 25/B3059r/102 | 25' | 1/9 |
| 25/B3059s/203 | 50' | 3/6 |
| 25/B3059t/400 | 100' | 6/9 |
| No. 2 Size. | | Each |
| No. | Length | |
| No. 25/B3059w/ | 25' | — |
- Specially suitable for G.B. Brakes.

PRICES shown do NOT include PURCHASE TAX which will be charged at current rates where applicable

Branches
 Aberdeen, Ayles, Belfast
 Birmingham, Bournemouth
 Bristol, Cardiff, Exeter
 Glasgow, Dublin, Dundee
 Southampton, Glasgow
 Hull, Ipswich, Leeds

Head Office and Warehouse, Wholesale only:

GREAT EASTERN STREET, LONDON, E.C.2

134 GEORGE STREET EDINBURGH, 2

Branches
 Liverpool, Manchester
 Newcastle-upon-Tyne
 Nottingham, Oxford, Preston
 Reading, Southampton
 Swansea, Telford
 Wolverhampton

BRAKE CABLE WIRES—continued

BRAKE CABLE NIPPLES

G.R. HIDUMINIUM POLISHED
BRAKE CABLE LUBRICATORS

Complete with two Oil Gun Nipples fitted,
and four loose cable ferrules. Each supplied
in sealed envelopes.

With full fitting instructions.

No. 25/B3057/108 each 2/6

OIL GUNS

See under "Oil Cans"

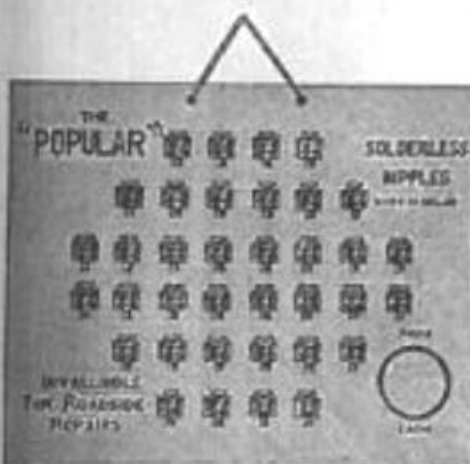
BRAKE CABLE NIPPLES
(SOLDERLESS)

New improved pattern Eye Bolt type.

For Inner Cable Brake Wires.

Suitable for Cycles and Motor Cycle Wires.

These Nipples are a more robust type and
grip the Brake Wire on both sides of the
Nipple and are tightened up with a hexagon
nut, see illustration.

Packed on cards of 3 dozen.

No. 25/B3061e/706 per card 11/3 No. 25/B3060k/603 per card 9/6 No. 25/B3061c/603 per card 9/6

PRICES shown do NOT include PURCHASE TAX which will be charged at current rates where applicable

Branches
Aberdeen, Aston, Belfast
Birmingham, Bournemouth
Bristol, Cardiff, Carlisle
Croydon, Dublin, Dundee
Exeter, Glasgow
Hull, Ipswich, Leeds

Head Office and Warehouse, Wholesale only:

GREAT EASTERN STREET, LONDON, E.C.2

124 GEORGE STREET EDINBURGH, 2

Branches
Liverpool, Manchester
Newcastle-upon-Tyne
Nottingham, Oxford, Preston
Reading, Southampton
Sunderland, Tynes
Wolverhampton

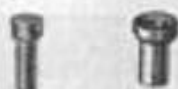

BRAKE CABLE BRASS NIPPLES

For Inner Cable Brake Wires.

For "Hercules" and "Webb" Brakes.

No. 25/B3060aa/9 per doz. 1/2

For "Resilion" Brakes.

No. 25/B3060a/10 per doz. 1/3



BRAKE CABLE NIPPLES

For Inner Cable Brake Wires.

In boxes of 1 gross assorted.

No. 25/B3060b/900 per box 13/6

RESILION LEVER END CABLE
NIPPLES

For New Pattern Cantilever and Cantilette
Brakes.

No. 25/B3060c/9 per doz. 1/2

For Old Pattern.

No. 25/B3060d/9 per doz. 1/2

BRAKE CABLE NIPPLES
(SOLDERLESS)

For Inner Cable Brake Wires.

Packed on cards of 3 dozen.



BRAKE INNER CABLE WIRES

No. 1, with round barrel type nipple and plain
brake end.

No.		per doz.
25/B3057g/307	Front ..	5/4
25/B3057k/408	Rear, Gent's	7/-
25/B3057l/508	Rear, Ladies'	8/6

No. 2, extra stout, complete with one
soldered-on nipple.

For G.B. Brakes.

No. 25/B3058p/6	Front ..	each	9/-
25/B3058r/8	Rear, Gent's	..	1/-



FOR NEW TYPE CONTROLS
GEAR WIRES & BRAKES
PRICE EACH

BRAKE CABLE NIPPLES
(SOLDERLESS)

With Set Screw for Inner Cable Brake Wires.
To replace round lever end nipples.

Size 1/4" dia. Nickel Plated.

Packed on cards of 3 dozen.

No. 25/B3061c/603 per card 9/6

BRAKE CABLE NIPPLES—continued CABLE SUNDRIES

BRAKE CABLE BRASS NIPPLES

For Inner Cable Cycle Brake Wires.

No. 25/B3060f/10	Size $\frac{1}{8}$ " dia. x $\frac{1}{4}$ " wide for Anchor.	per doz.	1/9
No. 25/B3060m/10	Size $\frac{1}{8}$ " dia. x $\frac{1}{4}$ " wide.	per doz.	1/3
No. 25/B3060n/10	Size $\frac{1}{8}$ " dia. x $\frac{1}{4}$ " wide.	per doz.	1/3
No. 25/B3060p/10	Size $\frac{1}{8}$ " dia. x $\frac{1}{4}$ " wide for Phillips.	per doz.	1/3
No. 25/B3060t/10	Size $\frac{1}{8}$ " dia. x $\frac{1}{4}$ " wide for Constrictor.	per doz.	1/3
No. 25/B3060w/10	Size $\frac{1}{8}$ " dia. x $\frac{1}{4}$ " wide for Raleigh.	per doz.	1/3
No. 25/B3060x/102	Size $\frac{1}{8}$ " dia. x $\frac{1}{4}$ " wide for Hercules.	per doz.	1/9
No. 25/B3060z/10	Size $\frac{1}{8}$ " dia. x $\frac{1}{4}$ " wide.	per doz.	1/3



"VAR" BRAKE SHOE CLAMP

No. 11.

Hold the brake shoes in position, leaving both hands free, one to insert the cable end, and the other to tighten the stirrup eye bolt nut. The holding clamp is pushed into the required position, with the brake blocks at the required clearance from the rims, and the set-screw tightened. Continental make.

No. 25/B3062/1500 .. each 22/6



BRAKE CABLE BRASS NIPPLES

These boxes of assorted Nipples contain patterns to suit all present-day Hub and Caliper Brakes and are most useful to all cycle agents.

For Inner Cable, Rim and Hub Brake Wires.

Round Pattern for Levers.

In boxes of $\frac{1}{2}$ gross assorted.

No. 25/B3061f/508 .. per box 8/3

Round Lever Pattern and Ordinary Cable End Nipples.

In boxes of $\frac{1}{2}$ gross assorted.

No. 25/B3061h/508 .. per box 8/3



PHILLIPS ANCHOR PINS AND NUTS

For Side Pull Brakes.

No. 508-25x.

No. 25/B3061x/302 .. per doz 4/9



PHILLIPS BELL CRANKS

For "Vindex" and "Phillips" Rear Fall-up or Roller Brakes.

Black Enamelled.

Complete with Bolts and Nuts (as Illustrated).

Clip Fitting for $1\frac{1}{2}$ " Tubes.

No. 25/B3064g/771	For right-hand side fitting.	No. B10-5x	each	1/5
25/B3064g/1000			per doz.	—
No. 25/B3064c/9	Bolt fitting. $\frac{1}{4}$ " dia. x 2" long.	No. B10-6x	each	1/1
25/B3064c/808	For left-hand side fitting.		per doz.	—



PHILLIPS HEXAGON HEAD BELL CRANK BOLTS

With shouldered nut and two curved washers.

Size $\frac{1}{2}$ " dia. x 2" long.

For Yoke and Hinge.

No. 25/B3066a/6	No. 506-10x	each	—/9
25/B3066a/507		per doz.	—

With two ordinary nuts and one curved washer.

Size $\frac{1}{2}$ " dia. x 2" long.

For Standard and Carrier.

No. 25/B3066p/6	No. 508-4x	each	—/9
25/B3066p/506		per doz.	—



TERRY CYCLE CABLE NIPPLES AND STOPS (No. 1247)

For Cable Brakes and Three-Speed Cables.

Packed in divisional boxes, comprising 15 different types and 13 $\frac{1}{2}$ dozen in all.

No. 25/B3061t/1004 .. per box 15/6



G.B. CABLE SOCKET

Complete with Hexagon Nut, Plated.

No. 25/B3061y/6	each	—/9
25/B3061y/504	per doz.	—

G.B. CABLE CLAMP BOLTS

Complete with Domed Nut, Plated.

No. 25/B3061z/6	each	—/9
25/B3061z/600	per doz.	—

PRICES shown do NOT include PURCHASE TAX which will be charged at current rates where applicable

Branches
Aberdeen, Acton, Belfast
Birmingham, Bournemouth
Bristol, Cardiff, Exeter
Glasgow, London, Reading
Sheffield, Southampton
Preston, Liverpool

Head Office and Warehouse, Wholesale only.

GREAT EASTERN STREET, LONDON, E.C. 2

126 GEORGE STREET, EDINBURGH, 2

Branches
Liverpool, Manchester
Newcastle-on-Tyne
Nottingham, Oxford, Preston
Reading, Southampton
Sheffield, Tyneside
Wolverhampton

BRAKE LEVERS



PHILLIPS ALLOY HOODED BRAKE LEVER No. 9.

Complete with clip For "Phalite."
No. CB11-90.

No. 25/B3093p/307 each 5/4

PHILLIPS ROLLER BRAKE LEVERS

Complete with nut and washer only for fitting to brakes of the stud lug type Chromium Plated. Long Pattern.

Front. For Right-hand Fitting.

Ordinary Raised.

No. 25/B3087b/11 No. B11-1x each 1/4
25/B3087b/1010 .. per doz. —

North Road Raised.

No. 25/B3087n/100 No. B11-12x each 1/6
25/B3087n/1103 .. per doz. —

Rear. For Left-hand Fitting

Ordinary Raised.

No. 25/B3088b/11 No. B11-1x each 1/4
25/B3088b/1010 .. per doz. —

North Road Raised.

No. 25/B3088nc/100 No. B11-12x each 1/6
25/B3088nc/1103 .. per doz. —



WEBB HOODED BRAKE LEVERS

Chromium Plated.

Complete for $\frac{3}{8}$ " dia. bars.

No. 25/B3090h/404 each 6/6

WEBB STANDARD STEEL BRAKE LEVERS

Chromium Plated.

No. 25/B3090b/309 each 5/-

"ALP" ALLOY HOODED BRAKE LEVER

Complete with clips. Polished alloy.
For Left and Right hand use.

No. 25/B3095k/1108 .. per pair 17/6



PHILLIPS SOLID STEEL BRAKE LEVERS

No. 11 Lever. Chromium Plated.

Complete with clip for "Phalco" and "Vox Populi."

No. 25/B3093m/110 No. CB11-110 each 2/9

ASHBY SOLID BRAKE LEVER

Complete with clip. Chromium.

No. 25/B3094e/200 each 3/-



"RESILION" CANTILEVER COUPLED BRAKE LEVERS

Complete with $\frac{1}{2}$ " clip, bolt, nut and clamp block. Ordinary pattern with additional lug or ear for use with coupling front and rear brakes to work on one lever.

Chromium.

No. 25/B3096m/568 each 8/6



DOHERTY CALIPER BRAKE LEVER

Curved Tourist Pattern Solid.
Complete with two-screw clip.

No. 25/B3090w/209 Chromium each 4/3



DOHERTY ALLOY CALIPER HOODED BRAKE LEVER

Complete with band clip.

No. 25/B3095a/404 each 6/6



DOHERTY CALIPER BRAKE LEVER, SPORTS PATTERN

With $\frac{1}{2}$ " band clip, roller nipple and cable nipple.

Alloy Polished.

No. 25/B3095c/400 each 6/-

Chromium Plated Steel.

No. 25/B3095d/300 each 4/6



RESILION CANTILEVER POLISHED LIGHT ALLOY BRAKE LEVERS

Complete with clip, bolt, nut and clamp block.

Ordinary straight pattern.

Without lever lock.

No. 25/B3096p/700 each 10/6

With lever lock and two keys.

No. 25/B3096pt/1302 each 17/6

"C" shaped cranked pattern.

Without lever lock.

No. 25/B3096r/700 each 10/6

With lever lock and two keys.

No. 25/B3096rt/1302 each 17/6

PRICES shown do NOT include PURCHASE TAX which will be charged at current rates where applicable

Branches
Aberdeen, Acton, Belfast
Birmingham, Bournemouth
Bristol, Cardiff, Carlisle
Glasgow, London, Dundee
Eastbourne, Glasgow
Hull, Ipswich, Leeds

Head Office and Warehouse, Wholesale only

GREAT EASTERN STREET, LONDON, E.C.2

124 GEORGE STREET EDINBURGH, 2

Branches
Liverpool, Manchester
Newcastle-upon-Tyne
Nottingham, Oxford, Preston
Reading, Southampton
Sheffield, Stoke-on-Trent
Wolverhampton

BRAKE LEVERS, CLIPS, RODS, ETC. BRAKE SHOES WITH BLOCKS



G.B. HIDUMINIUM LIGHT ALLOY CALIPER BRAKE LEVER
Complete with clip.

Hooded type for racing.

No. 25/B3095g/500 each 7/6

Curved ordinary type for tourist.

No. 25/B3095h/500 each 7/6

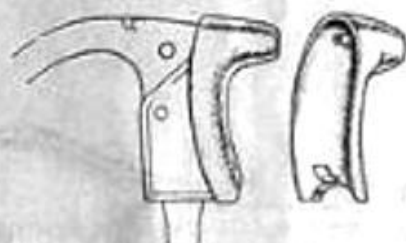

"MAFAC" RUBBER CALIPER BRAKE LEVER GRIPS
(Foreign.)

Specially moulded to fit Alp Hooded brakes (B1438a-b)

Very neat and effective, made with metal insert at lever clip end, and fitted with nipple through which inner wire passes at the other end.

No. 25/B3097m/504 per pair 8/-



PHILLIPS STUD LUGS

With collar and screwed nut for roller lever brakes.

Chromium Plated.

No. 25/B3146g/211 per doz. 6/-



PHILLIPS BRAKE ROD

With lug and screw.

Cadmium Plated, for roller lever brakes.

Front. No. B13-1R.

No. 25/B3149k/209 per doz. 4/2



"SHOCKSTOP" CALIPER BRAKE LEVER GRIP

To suit various types of hooded brake levers.

Made of highly resilient quality rubber, which does not impair brake action.

No. 25/B3097s/106 Black per pair 2/3



PHILLIPS BRAKE RODS,

With lugs and lever stop, for Front roller lever brakes.

For Front on Right-hand side.

Chromium Plated

No. 25/B3149r/6 No. B10-1X each -/9
25/B3149r/502 per doz. -



"PHILLIPS" BRAKE ROD, with lug and lever stop, for Rear roller brakes.

For Rear on Left-hand side.

Chromium Plated.

No. 25/B3151c/6 No. B10-2X each -/9
25/B3151c/502 per doz. -



PHILLIPS DOWN TUBE FRAME RODS

With lug and rivet for Rear brakes.

To suit "Crabbe" and "Phillips."

No. 25/B3153f/210 No. B13-2X per doz. 4/3



JOHN BULL BRAKE SHOES

Fitted with blocks and complete with bolts, nuts and washers.

On display cards of 12 Pairs.

No. 6 to suit "Standard."

No. 25/B3168s/1400 per card 21/-

No. 19 to suit "Raleigh," "Hercules" and "Royal Enfield."

No. 25/B3168b/1400 per card 21/-

"BANTEL" BRAKE SHOES

Plated brake shoes complete with rubber pads. Packed individually in cellophane envelopes.

On display cards of 12 pairs.

For Roadster. No. C162.

No. 25/B3163a/904 per card 14/-

For Sports. No. C168.

No. 25/B3163d/904 per card 14/-



"G.B." BRAKE LEVER PARTS

Handlebar lever clip with screw and lock nut

No. 25/B3105a/10 For $\frac{1}{8}$ " bar each 1/3

25/B3105b/10 For $\frac{3}{16}$ " bar .. 1/3

Screw and lock nut for clip.

No. 25/B3105e/6 each -/9

Lever pivot screw and pivot bush.

No. 25/B3105g/4 each -/6

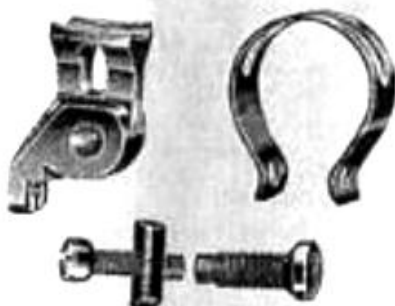

RESILIENT LEVER BAND CLIP FOR CANTILEVER AND CANTILETTE BRAKES.

Lever band clip only.

No. 25/B3100e/5 Black .. each -/8

25/B3100e/504 .. per doz. -

25/B3100f/5 Chromium each 1/2

25/B3100f/504 .. per doz. -

Clip bolt and half-round nut for band clip.

No. 25/B3100h/6 Black .. each -/9

25/B3100h/504 .. per doz. -

25/B3100k/9 Chromium each 1.2

25/B3100k/904 .. per doz. -

Lever bolt only.

No. 25/B3098r/4 Black .. each -/6

25/B3098a/6 Chromium .. -/9

Centre block piece. Black only.

No. 25/B3100w/104 each 2/-



PRICES shown do NOT include PURCHASE TAX which will be charged at current rates where applicable

BRAKE SHOES WITH BLOCKS—continued



FERODO BRAKE SHOES

Nickel plated brake shoes complete with rubber pads.

On Display Cards of 12 pairs.

For Roadster No. 51A

No. 25/B3164t/1600 .. per card 24/-

Wedge Pattern. No. 52

No. 25/B3164h/1600 .. per card 24/-

For Raleigh No. 57A

No. 25/B3164r/1600 .. per card 24/-

For Raleigh Caliper No. 98B

No. 25/B3164z/1600 .. per card 24/-



GATO ROADSTER ALLOY BRAKE SHOE

With grey rubber wedge type blocks. Wide section, complete with screws, washers and patent lock nut.

No. 25/B3165f/1000 .. per doz. pairs 15/-

"BELVIN" BRAKE SHOES

Black Enamelled, wide pattern with grey wedge rubber blocks, with bolts and nuts.

No. 25/B3165n/608 .. per doz. pairs 10/-



BRAKE SHOES

Fitted with Rubber Blocks.

Narrow Section.

Complete with plated bolts, nuts and washers.

Nickel Plated.

No. 25/B3165g/800 .. per doz. pairs 12/-



BRAKE SHOES

Fitted with wedge type grey rubber blocks. Wide section. Complete with plated bolts, nuts and washers.

Nickel Plated.

No. 25/B3165t/700 .. per doz. pairs 10/6



FIBRAX BRAKE SHOES

Plated brake shoes complete with Rubber pads.

On Display Cards of 12 pairs.

Standard Pattern.

No. 25/B3170f/1400 .. per card 21/-



GATO POLISHED ALLOY BRAKE SHOE

Complete with screws, washers and patent lock nut.

Fitted with "Fibrax" brake blocks for "Endrick" rims.

No. 25/B3172w/11 .. per pair 1/4

25/B3172w/1000 .. per doz. pairs

Fitted with soft rubber blocks to suit alloy rims.

No. 25/B3172x/9 .. per pair 1/1 1/2

25/B3172x/866 .. per doz. pairs



PHILLIPS BRAKE SHOES

Wide pattern with grey wedge rubber blocks with bolts and nuts. Packed one pair in cellophane bag and twelve pair on show card. Chromium Plated.

No. 25/B3170b/710 No. B2-1x per card 11/9



BRAKE SHOES with Pads

Suitable for Juvenile Tricycles. Complete with bolts, nuts and washers. Packed on showcards of 1 dozen pairs.

No. 25/B3165w/600 .. per card 9/-



BRAKE SHOES

For "Raleigh" Roadster Front and Rear Brakes.

Complete with plated bolts, nuts, washers and bush.

Nickel Plated.

No. 25/B3171c/9 .. per pair 1/1 1/2



BRAKE SHOES, fitted with Rubber Blocks.

Complete with bolts and nuts.

For "Webb" Side Pull Brakes.

No. 25/B3171w/9 .. per pair 1/1 1/2

For Monitor Sheerline Brakes, with Stabilisers.

No. 25/B3173p/11 Front .. per pair 1/5

25/B3173r/11 Rear 1/5



"STRATA" GALIPER ALLOY BRAKE SHOE

Fitted with Ferodo No. 109 Brake Blocks. Complete with bolts, nuts and washers.

No. 25/B3171x/1200 .. per doz. pairs 18/-



PHILLIPS BRAKE SHOES AND PADS

On Cards of 1 dozen pairs.

For "Vox Populi."

No. 25/B3172f/1003 CB2-1x per card 15/6

For "Phillite."

No. 25/B3172g/1410 CB2-7x per card 22/3

PRICES shown do NOT include PURCHASE TAX which will be charged at current rates where applicable

Branches
Aberdeen, Aden, Belfast
Birmingham, Bournemouth
Bristol, Cardiff, Carlisle
Croydon, Dublin, Dundee
Eastbourne, Glasgow
Hull, Inverness, Leeds

Head Office and Warehouse, Wholesale only

GREAT EASTERN STREET, LONDON, E.C.2

126 GEORGE STREET EDINBURGH, 2

Branches
Liverpool, Manchester
Newcastle-upon-Tyne
Nottingham, Oxford, Preston
Reading, Southampton
Stoke-on-Trent
Wolverhampton

BRAKE SHOES WITH BLOCKS—continued. BRAKE BOLTS AND SPRINGS, ETC.



PHILLIPS
BRAKE SHOES,
fitted with Rubber
Blocks

For "Thilco" Brakes. Nickel Plated.

Front No. CB2-4x.

No. 25/B3172k/707 per doz. pairs 11/3

Rear No. CB2-4x.

No. 25/B3172r/707 per doz. pairs 11/3



PHILLIPS BRAKE SHOE SCREWS

Complete with nuts and washers.

Plated. $\frac{3}{8}$ " x 30 thread.

No. 506-2x.

No. 25/B3176f/11 per doz. 1/5



BRAKE SPRINGS

For Caliper Brakes.

To suit "Hercules."

No. 25/B3184h/209 Front per doz. 4/3

25/B3184k/209 Rear .. 4/3

To suit "Raleigh."

No. 25/B3184r/200 Front per doz. 4/6

25/B3184e/200 Rear .. 4/6



G.B. CALIPER BRAKE SPRINGS

Cadmium Plated.

No. 25/B3184c/5 .. each -/7 $\frac{1}{2}$

25/B3184t/409 per doz. —

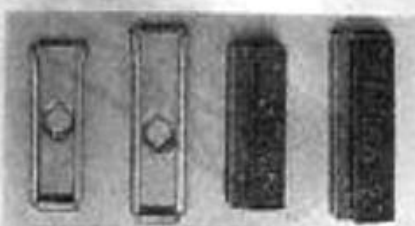

G.B. CALIPER ALLOY BRAKE
SHOES

Complete with brake blocks, screw domed
nut and washer.

No. 25/B3173a/102 .. per pair 1/8

25/B3173a/1204 doz. pairs —

BRAKE SHOES

Fitted with Rubber Blocks.

For Raleigh Caliper

Complete with bolts, nuts and washers.

Nickel Plated.

No. 25/B3172r/806 per doz. pairs 12/9



G.B. BRAKE SHOE FIXING SCREW
(with Washer and Domed Nut).

Chromium Plated.

No. 25/B3176l/5 .. each -/7

25/B3176l/408 per doz. —

Domed Nut only. Chromium Plated.

No. 25/B3176a/200 .. per doz. 3/-



PHILLIPS BRAKE SPRINGS

For "Phillips" Bolt Fitting.

No. 25/B3184w/210 .. per doz. 4/3



WEBB BRAKE SPRINGS

No. 25/B3184z/200 .. per doz. 3/-



RESILION CANTILEVER BRAKES
SHOES

Complete with Blocks, Screws and Nuts
For Front Brakes.
Chromium Plated.

No. 25/B3174b/208 per pair 4/-
Black.

No. 25/B3174c/200 .. per pair 3/-

For Ordinary Rear Brakes.

Chromium Plated.

No. 25/B3174k/208 .. per pair 4/-

All Black.

No. 25/B3174l/200 .. per pair 3/-

For Tandem

Chromium Plated.

Front.

No. 25/B3174n/208 .. per pair 4/-

Rear.

No. 25/B3174r/208 .. per pair 4/-

For Cantiletto Brakes.

Chromium Plated.

Front.

No. 25/B3175c/107 .. per pair 2/4

Rear.

No. 25/B3175m/107 .. per pair 2/4



PHILLIPS BRAKE SPRINGS

For "Phillips" Central Pull Brakes.

Chromium Plated. No. SP1-1.

No. 25/B3184b/108 .. per doz. 2/6



BRAKE SPRINGS

For "Monitor" "Shearline" Brakes.

Front and Rear.

No. 25/B3184n/302 .. per doz. 4/9



PHILLIPS BRAKE SPRINGS

For Standard Roller Lever Models.

Front. No. SP1-1.

No. 25/B3186c/107 .. per doz. 2/6

Rear. No. SP1-2.

No. 25/B3186d/107 .. per doz. 2/6

PRICES shown do NOT include PURCHASE TAX which will be charged at current rates where applicable

Branches
Aberdeen, Ayr, Belfast,
Birmingham, Blackburn,
Bristol, Cardiff, Cardiff,
Croydon, Dublin, Dundee,
Exeter, Glasgow,
Hull, Ipswich, Leeds.

Head Office and Warehouse, Wholesale only

GREAT EASTERN STREET, LONDON, E.C.2

125 GEORGE STREET EDINBURGH, 1

Branches
Liverpool, Manchester,
Newcastle-upon-Tyne,
Nottingham, Oxford, Preston,
Reading, Southampton,
Sheffield, Tyneside,
Wolverhampton.

BRAKE EYE BOLTS, REPLACEMENT PARTS, ETC.



FRONT FORK OR REAR STAY CLIPS

For round peg guides. Two-screw fitting.

For $\frac{1}{2}$ " "D."

Nickel Plated.

No. 25/B3200a/703 per doz. pairs 11/-

All Black.

No. 25/B3200c/609 per doz. pairs 10/3

For $\frac{1}{2}$ " round.

All Black.

No. 25/B3200f/609 per doz. pairs 10/3

For $\frac{1}{2}$ " "D" (Juvenile).

Cadmium Plated.

On Display Cards of 1 dozen pairs.

No. 25/B3200z/705 per card 11/6



GATO JUVENILE CLIPS

One-screw fixing, to fit on small size forks.

For various makes of Toy Cycles.

No. 25/B3200x/6 Plated per pair -/9

RESILION

SPARE BRAKE PART CABINETS

For Cantilever Brakes, containing good assortment of all popular good selling replacement parts including Front and Rear Cables, Levers, Brake Blocks, etc. Less Cable Units.

No. 25/B3255a/10300 Complete —



PHILLIPS BRAKE FORK CLIPS

Chromium Plated.

On cards of twelve pairs.

 $\frac{1}{2}$ " round. Standard.

No. 25/B3200p/900 B16-24x per card 13/6

For "Kiddies" Models.

No. 25/B3200r/709 B16-16x per card 10/6



PHILLIPS FRONT FORK CLIPS

For round peg guide, standard $\frac{1}{2}$ " "D"
Packed one pair in cellophane bag and twelve pairs of above. No. B16-1a.

Chromium Plated.

No. 25/B3200r/709 Card of doz. pairs 10/6

PHILLIPS BRAKE TUBE TOP END LUG

To take Eye Bolt.

Chromium Plated. No. B4-1.

Screwed for $\frac{1}{2}$ " dia. tube.

No. 25/B3214c/307 per doz. 5/3



BRAKE TUBE EYE BOLTS

With Hexagon Nuts and Washers.

Chromium Plated. Best quality.

 $\frac{1}{8}$ " dia. to take $\frac{1}{8}$ " rod.

"Phillips"

No. 25/B3215c/111 B5-1x per doz 3/-

For various makes.

 $\frac{1}{8}$ " dia. to take $\frac{1}{8}$ " rod.

No. 25/B3215f/200 .. per doz 3/-

 $\frac{1}{8}$ " dia. x $\frac{1}{8}$ " long to take $\frac{1}{8}$ " rod to suit

"B.S.A." Brakes.

No. 25/B3215h/200 .. per doz. 3/-

For "Hercules" $\frac{1}{8}$ " dia. to take $\frac{1}{8}$ " rod.

No. 25/B3215p/200 .. per doz. 1/6

For "Raleigh."

No. 25/B3215r/200 .. per doz. —

BRAZING SPECTER

Fine.

No. 25/B3336a/309 .. per lb. —

25/B3336a/308 .. 7lb. lots —

25/B3336a/308 .. 28lb. lots —

Medium.

No. 25/B3336b/309 .. per lb. —

25/B3336b/308 .. 7lb. lots —

25/B3336b/308 .. 28lb. lots —

Coarse.

No. 25/B3336c/309 .. per lb. —

25/B3336c/308 .. 7lb. lots —

25/B3336c/308 .. 28lb. lots —

Special Soft Specter or White Solder runs at

a low heat, for tin, brass, copper tubes, etc.

No. 25/B3336s/209 .. per lb. —

25/B3336s/208 .. 7lb. lots —



PHILLIPS BRAKE TUBES

With Top End Lug and Eye Bolt for Front Brakes.

Chromium Plated. No. B3-IF, B5-1X.

For 9" Head

No. 25/B3208e/11 .. each 1/4

25/B3208e/1005 .. per doz. —



PHILLIPS BRAKE TUBES

With Bottom Yoke End Lug and Screw and Top End Lug with Eye Bolt, for Rear Brakes.

Chromium Plated.

No. B3-1N, B5-1X, S06-6.

7" for 9" Head

No. 25/B3211e/102 .. each 1/9

25/B3211e/1308 .. per doz. —



PHILLIPS BRAKE TUBE BOTTOM END LUG

With Screw. Chromium Plated.

For $\frac{1}{8}$ " rods. No. B7-3/S06-6.

No. 25/B3217dc/405 .. per doz. 6/9

Screws only for above. No. S06-6.

No. 25/B3217rc/6 .. per doz. -/9

BRAZING PEGS.

 $\frac{1}{8}$ " dia. tapered to $\frac{1}{16}$ " dia. x $\frac{1}{2}$ " long with flat head and pin point.

No. 25/B3323/6 .. per gross —

25/B3323/6 12-25 Gross lots —

BRAZING WIRE

Flat.

No. 25/B3335a/211 .. per lb. —

25/B3335a/210 .. 7lb. lots —

25/B3335a/209 .. 28lb. lots —

25/B3335a/208 .. 56lb. lots —

Round.

No. 25/B3335b/200 .. per lb. —

25/B3335b/211 .. 7lb. lots —

25/B3335b/210 .. 28lb. lots —

Soft Brazing Strip.

Grooved specially for copper and brass.

No. 25/B3335s/402 .. per lb. —

25/B3335s/401 .. 7lb. lots —

25/B3335s/311 .. 28lb. lots —

PRICES shown do NOT include PURCHASE TAX which will be charged at current rates where applicable

Branches
Aberdeen, Aston, Belfast
Birmingham, Bournemouth
Bristol, Cardiff, Carlisle
Croydon, Dublin, Dundee
Leamington, Glasgow
Millwall, London

Head Office and Warehouse, Wholesale only

GREAT EASTERN STREET, LONDON, E.C.2

134 GEORGE STREET, EDINBURGH, 1

Branches
Liverpool, Manchester
Newcastle-upon-Tyne
Nottingham, Oxford, Preston
Reading, Southampton
Sheffield, Tyneside
Wolverhampton

CARRIERS (Basket) CARRIERS AND FLASKS

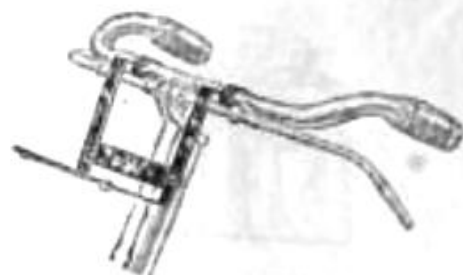
**" UNIVERSAL " BASKET CARRIER**

Black Enamelled with Plated Clips.

To fit on handlebar and stem with long adjusting bolts and nuts. Drilled and fitted with three bolts, nuts and washers, to secure basket to carrier.

No. 25/C122p/106 each 2/-

**TERRY BASKET CARRIER**

Black Enamelled with Plated Bolts and Wing Nuts.

To fit on handlebar stem and plates with large washers to fit inside of basket.

No. 25/C122t/200 each 3/-

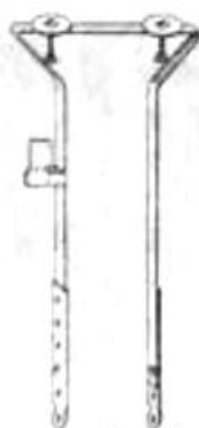
**CARRIER OR SUPPORT FOR HANDLEBAR BASKET**

Black Enamelled with adjustable legs for 26" or 28" wheels with large round alloy washer, screws and nuts to fit through basket to keep same rigid.

Front wheel spindle fitting.

With lamp bracket fitted on side of leg.

No. 25/C122x/300 each 4/6

With lamp bracket fitted at top and front of carrier.

No. 25/C122w/303 each 4/11

REPLACEMENT CORKS TO SUIT ALUMINIUM FLASKS

With metal top to suit "Coloral" Flasks.

No. 25/C128w/208 .. per doz. 4/-

Large Size.

To fit Continental No. 25/C130w and 25/C131d, e

No. 25/C130t/108 .. per doz. 2/6

Small Size.

To fit Aluminium Flasks, No. 25/C131h.

No. 25/C131s/106 .. per doz. 2/3

**COLORAL ALUMINIUM DRINKING FLASKS**

Anodised in various colours.

Ribbed Section.

No. 25/C127L/300	Blue	..	each	4/6
25/C127m/300	Red	..	"	4/6
25/C127n/300	Green	..	"	4/6
25/C127r/300	Silver	..	"	4/6

Polished Alloy.

No. 25/C127t/207	each	3/11
------------------	----	----	------	------

Shaped Pattern.

Plain Section.

No. 25/C128b/303	Blue	..	each	4/11
25/C128c/303	Red	..	"	4/11
25/C128d/303	Green	..	"	4/11
25/C128g/303	Silver	..	"	4/11

Ribbed Section.

No. 25/C128L/303	Blue	..	each	4/11
25/C128m/303	Red	..	"	4/11
25/C128n/303	Green	..	"	4/11
25/C128r/303	Silver	..	"	4/11

The above ranges of "Coloral" Feeding Bottles are suitable for both No. 25/C127x/z and No. 25/C128x/z Flask Carriers.

No. 25/C128x/z Flask Carriers.

**CONTINENTAL POCKET ALUMINIUM FLASKS**

Very light and strong, with cork and retaining chain.

Medium size.

No. 25/C129b/304 each 5/-

**COLORAL ALLOY FLASK CARRIERS**

Fitted with locking device as shown and constructed of a wide gauge strip material and of robust finish. Complete with Clips.

Anodised in various colours.

Blue, Red, Green and Silver.

No. 25/C127x/304	Single	..	each	5/-
25/C127x/306	Double	..	"	8/3

Extra Lightweight Flask Carrier.

Fitted with locking device similar to above, but constructed of a light gauge material.

No. 25/C128x/211	Single	..	each	4/5
25/C128x/302	Double	..	"	7/9

PRICES shown do NOT include PURCHASE TAX which will be charged at current rates where applicable

Branches
Aberdeen, Ayr, Belfast
Birmingham, Burnmouth
Bristol, Cardiff, Carlisle
Croydon, Dublin, Dundee
Exeter, Glasgow
Halfpenny, Leeds

Head Office and Warehouse, Wholesale only:

GREAT EASTERN STREET, LONDON, E.C.2

138 GEORGE STREET EDINBURGH, 2

Branches
Liverpool, Manchester
Newcastle-upon-Tyne
Nottingham, Oxford, Preston
Reading, Southampton
Sheffield, Truro
Wolverhampton

CARRIERS AND FLASKS—continued



"SIMPLEX" WIRE BOTTLE CARRIERS

With three clips for handlebar stem fitting
 No. 25/C130k/500 Single .. each 7/6
 25/C130l/600 Double 9/6
 With clips for down tube fixing
 No. 25/C130m/500 Single .. each 7/6

STANDARD POLISHED ALUMINIUM FLASKS

Suitable for use with Bottle Carriers
 Nos. 25/C130s and C131a/b.
 Complete with Corks.

Plain.
 No. 25/C131d/301 .. each 4/8
 Ribbed.
 No. 25/C131e/301 .. each 4/8

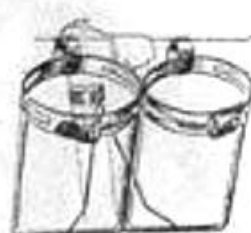
THE "CONTINENTAL" ALUMINIUM CARRIERS AND FLASKS
Carriers only.

With Special Spring Clip which releases or fastens at slightest pressure, eliminates rattle. Complete with stem and handlebar clips.

Double
 No. 25/C130a/508 each 5/6
 Flasks only.

Aluminium with Corks. Ribbed Section.
 No. 25/C130w/304 each 5/6

POLISHED ALUMINIUM FLASKS
SPECIAL LINE.

Complete with Corks.
 No. 25/C131g/203 Ribbed each 3/4



CYCLO "ROSALOY" FOLDING BOTTLE CARRIERS

Weight 3 1/2 oz. No. 1011. Packet flat.
 1 dozen in a carton.

No. 25/C130a/208 Single .. each 4/-
 25/C130b/400 Double 6/-



STRATA LIGHTWEIGHT FLASK CARRIERS

With special spring clip which releases or fastens at slightest pressure and eliminates rattle. With extra strengthening strut.

No. 25/C131a/208 Single .. each 3/9
 25/C131b/402 Double 6/3



STADIUM POLISHED ALUMINIUM FLASKS

Complete with Corks.
 Plain Section No. 142.

No. 25/C132m/310 each 4/3

Ribbed Section No. 142.

No. 25/C132n/210 each 4/3



ALUMINIUM FLASKS

Natural finish.

Standard size complete with Corks

No. 25/C131h/400 each 6/-

PRICES shown do NOT include PURCHASE TAX which will be charged at current rates where applicable

Branches
 Aberdeen, Ayr, Belfast
 Birmingham, Bournemouth
 Bristol, Cardiff, Carlisle
 Crayke, Dublin, Dundee
 Edinburgh, Glasgow
 Hull, Ipswich, Leeds

Head Office and Warehouse, Wholesale only:

GREAT EASTERN STREET, LONDON, E.C.2
 125 GEORGE STREET EDINBURGH, 2

Branches
 Liverpool, Manchester
 Newcastle-upon-Tyne
 Nottingham, Oxford, Preston
 Reading, Southampton
 Stoke-on-Trent
 Wolverhampton

CARRIERS AND FLASKS—continued CARRIERS (Rear, etc.)

COLORAL LOCKING BOTTLE
AND CARRIER COMBINED

Complete with Clips.

The locking action is simple. Thrust the bottle into the carrier and give a quarter turn. Alloy, finished in silver, gold, green, blue or red.

No. 25/C132c/708 per set 11/6

TERRY TENNIS RACKET OR
HOCKEY STICK CARRIER CLIPS

To fit on front fork, does not interfere with the steering, lamp or cyclometer (No. 787).

Enamelled.

No. 25/C132p/108 each 2/6

Chrome Plated.

No. 25/C132r/300 each 4/6



ASHBY "SUMMIT" CARRIER

Ebony Black. Size 14" x 5".

Complete with two leather straps.

Stay Fitting. No. 29.

No. 25/C143w/210 each 4/3



ASHBY "PRINCIP" CARRIER

Ebony Black. Size 13" x 5".

Complete with two leather straps.

Stay Fitting. No. 6B.

No. 25/C145r/301 each 4/8

"ALUMLITE" ALLOY LIGHTWEIGHT
SINGLE FLASK CARRIER

No. CA30.

With special spring clip which releases or fastens at slightest pressure and eliminates rattle. Etched and anodized finish in silver, bronze, gold, blue, green, red.

Single.

No. 25/C132g/300 each 4/6

Double.

No. 25/C132h/500 each 7/6

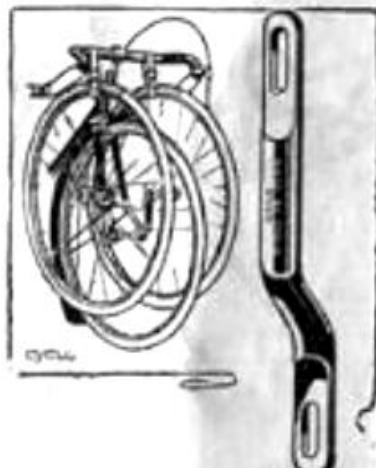

"ROSA" SPRINT WHEEL CARRIER

Designed to accommodate 26" or 27" wheels. Steel.

No. 25/C136a/300 per pair 4/6

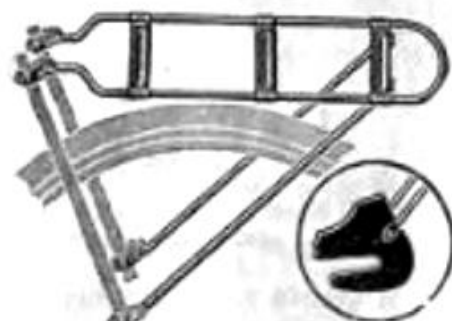
BROOKS "DREADNOUGHT"
LIGHTWEIGHT REAR
CARRIER, No. 47

Black Enamelled, less straps with clip to fit on back stays or can be fitted to mud-guard eye or fork end.

No. 25/C146r/304 each 5/-

"ALUMLITE" POLISHED
ALUMINIUM FLASKSComplete with Corks.
Ribbed Section.

No. 25/C132k/208 each 3/9

TERRY PRIMUS STOVE
CARRIER SPRING CLIPS

To fit on top tube, with swivel bolt and wing nut. Cadmium Plated. No. 1270.

Rustproof finish.

To suit Nos. 96 and 96t. Primus Stoves.

Small Size.

No. 25/C134f/108 each 2/6

To suit Nos. 210 and 210t. Primus Stoves.

Large Size.

No. 25/C134g/108 each 2/6

CAMPING EQUIPMENT

Tents. Oil Stoves. Picnic Outfits.

Please refer to SPORTS & TOYS

SECTION.

PRICES shown do NOT include PURCHASE TAX which will be charged at current rates where applicable

Branches
Aberdeen, Aston, Belfast
Birmingham, Bournemouth
Bristol, Cardiff, Carlisle
Croydon, Dublin, Dundee
Exeter, Glasgow
Hull, Ipswich, Leeds

Head Office and Warehouse, Wholesale only

GREAT EASTERN STREET, LONDON, E.C.2

126 GEORGE STREET EDINBURGH, 2

Branches
Liverpool, Manchester
Newcastle-upon-Tyne
Nottingham, Oxford, Preston
Reading, Southampton
Stoke-on-Trent
Wolverhampton

CARRIERS (Rear)—continued

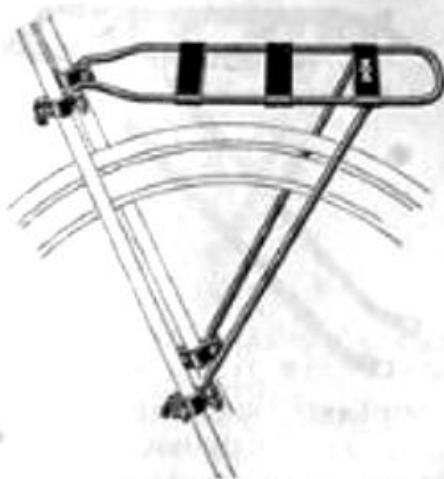
**"CEG" ROUND WIRE REAR CARRIER**

Black Enamelled with spring top, with four stay fitting clips, size 15" x 6".

No. 25/C146g/308 each 5/6

**LLOYD'S "QUICKFIT" TUBULAR BAG SUPPORTS**

Fitted with two half round plates to spring round top back stays. Suitable for 1/2" and 1" stays. Size 9" x 5" x 1/2" dia.

Black Enamelled on Steel.

No. 25/C148d/207 each 3/11

Polished Alloy.

No. 25/C148e/306 each 5/3

Chromium Plated on Steel.

No. 25/C148f/308 each 5/6

Stainless Steel.

No. 25/C148g/800 each 12/-

**BROOKS BAG SUPPORTS**

No. B2166.

Stay Fitting. Chromium Plated.

No. 25/C148n/204 each 5/-

**"SPORTSMAN'S" BAG CARRIER (No. 60.)**

With seat pillar fitting clip. Black Enamelled.

No. 25/C149x/100 each 1/6

**"BANELL" ALUMINIUM TUBULAR BAG SUPPORTS**

11" long x 4 1/2" wide.

With clip to fit on seat pillar and stays, with clips to fit on seat stays.

Polished or self colour (C267).

No. 25/C149a/500 each 7/6

Blue polychromatic finish (C267c).

No. 25/C149b/504 each 8/-

**"SPORTSMAN'S" BAG CARRIER**

With four clips to fit round top back stays and made to clear rear Caliper brake.

Silver finish. (No. 49.)

No. 25/C149t/204 each 3/6

With adjustable clip to fit 1" to 1 1/4" Seat pin and bottom back stays. Weight 13 oz.

Silver finish. (No. 50.)

No. 25/C149r/204 each 3/6

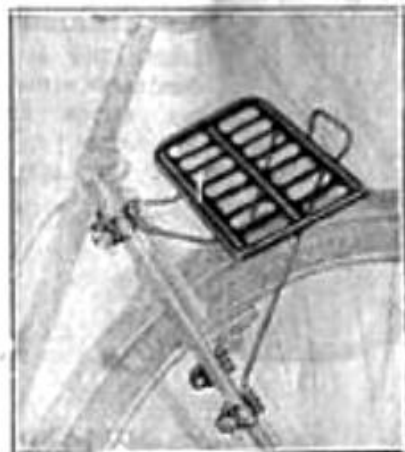
**"SPORTSMAN'S" BAG CARRIER**

With four clips to fit round top back stays and made to clear rear Caliper brake.

Silver finish. (No. 62.)

Size 11" x 5".

No. 25/C150e/204 each 3/6

Seat Stay and Seat Pillar fitting.

Silver finish. (No. 62sp.)

No. 25/C150h/204 each 3/6

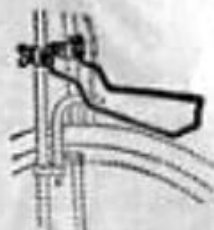
**WIRE FRAME CARRIER**

With clips for round stays.

"Sportsman's." (No. 48a.)

No. 25/C149w/100 each 1/6

PRICES shown do NOT include PURCHASE TAX which will be charged at current rates where applicable

Branches
Aberdeen, Aston, Belfast
Birmingham, Blackburn
Bristol, Cardiff, Cardiff
Croydon, Dublin, Dundee
Exeter, Glasgow
Hull, Ipswich, Leeds

Head Office and Warehouse, Wholesale only

GREAT EASTERN STREET, LONDON, E.C.2

124 GEORGE STREET EDINBURGH, 1

Branches
Liverpool, Manchester
Newcastle-upon-Tyne
Nottingham, Oxford, Preston
Reading, Southampton
Sunderland, Tynes
Wolverhampton

CARRIERS (Rear)—continued.

CARRIERS—TRADESMAN'S



MARTIN'S REAR TUBULAR CARRIER

Black Enamelled, spindle fitting and plate fitting to top of stays. With combined spring top parcel carrier and stand.

Size 17" x 7". No. C.102cs.

For 26".

No. 25/C161g/504 each 9/6

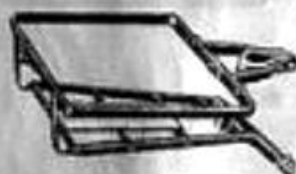

ASHBY TRADESMAN'S CARRIER

Black Enamelled. Extra Strong.

Size 18" x 12" inside, to suit oblong basket.

Fitted with lamp bracket.

No. 25/C181a/1108 each 17/6



TRADESMAN'S CARRIER

Black Enamelled. Extra Strong.

Carrier only, to suit oblong basket.

Size 18" x 12" inside. No. 44.

No. 25/C183b/1108 each 17/6



LLOYD'S TUBULAR REAR CARRIER

Black Enamelled, welded tubing, with spring clip for parcels. Size 15" x 6 1/2". For 26".

No. 25/C161k/411 each 7/4

"C.E.G." TUBULAR REAR CARRIERS

Spindle fitting, with spring top. Size 14 1/2" x 6". Black Enamelled.

No. 18.

No. 25/C160g/400 each 6/-

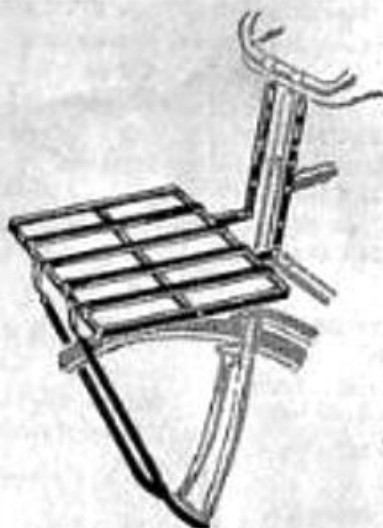

TRADESMAN'S "HANDY" CARRIER

Black Enamelled. Size 19" x 12".

Adjustable to suit 22" to 26" frames. No. 22.

No. 25/C181x/1000 each 15/-



LLOYD'S TUBULAR REAR CARRIER

Complete with stand.

Black Enamelled with spring clip.

For 26".

No. 25/C161l/504 each 9/6



ASHBY "CLIPON" CARRIER

Black Enamelled.

Size 18" x 12" inside. To suit oblong basket. Hook on handlebar and stay fitting.

No. 20s.

No. 25/C181s/1104 each 17/-



TRADESMAN'S CARRIER

Black Enamelled.

Size 18" x 12" inside, to suit oblong basket. No. 21 1/2.

No. 25/C181L/1000 each 15/-

PRICES shown do NOT include PURCHASE TAX which will be charged at current rates where applicable

Branches
Aberdeen, Aston, Belfast
Birmingham, Bournemouth
Bristol, Cardiff, Colchester
Croydon, Dublin, Dundee
Exeter, Glasgow
Hull, Ipswich, Leeds

Head Office and Warehouse, Wholesale only:

GREAT EASTERN STREET, LONDON, E.C.2

125 GEORGE STREET EDINBURGH, 3

Branches
Dorset, Manchester
Newcastle-on-Tyne
Nottingham, Oxford, Preston
Reading, Southampton
Sheffield, Truro
Widnes, Worcester

CARRIERS—CHILD



SACKVILLE "CYCLESEAT"

Suitable for child from age 18 months to 5 years and to suit lady's or gent.'s cycle. Black Enamelled.

No. 25/C184L/1008 each 16/-

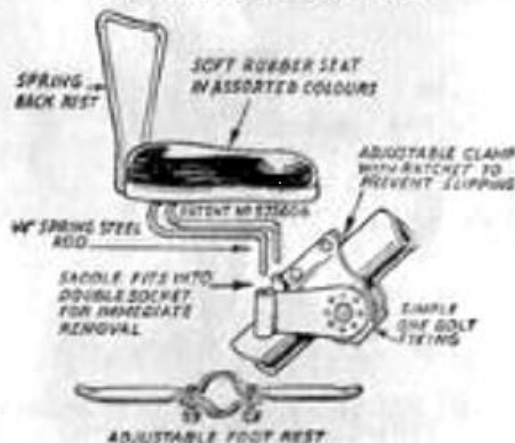

DERRETTS NEW MODEL SAFETY CHILD CARRIER (Patented.)

Universal fitting for gent.'s or lady's cycle. Saddle with back-rest easily detachable when not required and instantly re-fitted. Metal base, back-rest. Adjustable clip and foot-rest. Silver finish.

With special shaped coloured rubber top, waterproof resilient seat.

No. 28/C185d/1309 each 18/6

Foot-rests to suit above.

No. 25/C252d/100 each 1/6

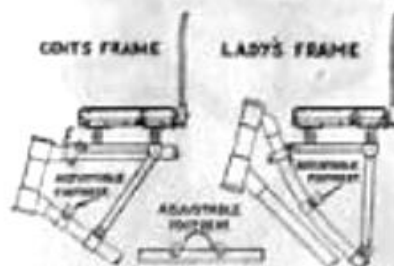

"UNIVERSAL" CHILD CARRIER

Spring model with foot-rests to suit both gent.'s or lady's cycle.

No. 25/C187m/900 each 13/6

ASHBY "RAMBLER" CHILD CARRIER

For attachment to rear of cycle with the child sitting with back to rider. Strong strip steel framework fitted with cranked and double twist arms. For 26" wheels.

Enamelled Black. Complete. No. 10. No. 25/C188h/1800 each 27/-

ASHBY "BABSCAR" CHILD CARRIER

Rear child carrier, complete with carrier for ordinary use. Child carrying attachment can easily be removed. Complete with safety strap.

Black Enamelled. No. 15. No. 25/C188x/1600 each 24/-

"TOM THUMB" CHILD CARRIER

Waterproof material cloth-covered saddle, wood base. With web stirrups, riveted.

Model No. 1.

No. 25/C186m/506} each 7/8

With web stirrups, fitted with plated quick-adjustable buckle.

Model No. 3.

No. 25/C186n/509 each 7/11



REAR CHILD CARRIER

Black Enamelled metal framework. Varnished ball wicker basket.

No. 25/C188L/1704 each 26/-



WILBY'S SADDLE WITH STIRRUPS

To suit gent.'s machine.

No. 25/C186x/1109 each 17/8



PRICES shown do NOT include PURCHASE TAX which will be charged at current rates where applicable

Branches
Aberdeen, Ayr, Belfast
Birmingham, Bournemouth
Bristol, Cardiff, Carlisle
Croydon, Dublin, Dundee
Eastbourne, Glasgow
Newcastle, Leeds

Head Office and Warehouse, Walsley only

GREAT EASTERN STREET, LONDON, E.C. 2

125 GEORGE STREET EDINBURGH, 2

Branches
Liverpool, Manchester
Newcastle-upon-Tyne
Nottingham, Oxford, Preston
Reading, Southampton
Sheff-on-Tees
Wolverhampton

CEMENT CYCLE CHAINS



"CROID" UNIVERSAL GLUE

A cold liquid animal glue.

Tubes.

No. 25/C285b/800 per doz. 12/-



"ACRABOND" TRIPLE STRENGTH LIQUID GLUE

In glass bottles with screw-on caps.

Display cartons of 1 doz.

No. 2 size 1 oz.

No. 25/C286c/800 .. per doz. 12/-

No. 1 size 2 oz.

No. 25/C286e/1200 .. per doz. 18/-

1/2 pint tin

No. 25/C286f/200 each 3/-



"CROID" AERO GLUE

A highly concentrated animal glue for hot application.

No. 25/C289d/800	2 oz. bottles	doz. 12/-
25/C289f/1200	4 " "	" 18/-
25/C289b/104	8 " tins	each 2/-
25/C289m/208	1 lb.	" 3/6
25/C289n/404	2 " "	" 5/9
25/C289r/1007	7 " "	" 13/-
25/C289z/3809	28 " "	" 47/6

TYRE CEMENT

please refer to TYRE SUNDRIES

"SECCOTINE"

For using Gold.

The handiest and most economical Adhesive known for making or mending anything of Wood, Iron, Bone, Delft, Paper, Pasteboard, Leather, Cloth, Glass, Ivory, etc.



Medium size tubes.

Packed in boxes of 1 dozen.

No. 25/C291e/800 .. per doz. 12

In Bulk for workshop or factory use.

No. 25/C291l/302 1/2 pint tins each 4/9

25/C291m/510 1 " " " 8/9

25/C291n/402 1 lb. " " 6/3

25/C291p/203 1/2 lb. " " 3/4

"RENOLD-ELITE" CYCLE CHAIN

With Spring Clip Fastening.



1/2" x 1/4". No. 111044.

No. 25/C346a/507	4' 6" or 108 links	.. each 7/11
25/C346b/601	4' 7" or 110 " "	" 7/11
25/C346c/502	4' 8" or 112 " "	" 7/11
25/C346d/503	4' 9" or 114 " "	" 7/11
25/C346e/504	4' 10" or 116 " "	" 7/11
25/C346g/506	5' 0" or 120 " "	" 7/11

For Tandems and Derailleur Gears.

No. 25/C346h/607 6' 0" or 144 links (111044) .. each 10/-

1/2" x 3/8". No. 111046.

No. 25/C346m/503	4' 9" or 114 links	.. each 7/11
25/C346n/504	4' 10" or 116 " "	" 7/11
25/C346r/506	5' 0" or 120 " "	" 7/11

"THE COVENTRY" CYCLE CHAIN

With Spring Clip Fastening.



1/2" x 1/4". No. 111048.

No. 25/C340a/311	4' 6" or 108 links	.. each 6/4
25/C340b/400	4' 7" or 110 " "	" 6/4
25/C340c/401	4' 8" or 112 " "	" 6/4
25/C340d/402	4' 9" or 114 " "	" 6/4
25/C340e/403	4' 10" or 116 " "	" 6/4
25/C340g/404 1/2	5' 0" or 120 " "	" 6/4

For Tandems and Derailleur Gears.

No. 25/C340h/503 6' 0" or 144 links (111048) .. each 9

1/2" x 3/8". No. 111049.

No. 25/C340k/400	4' 7" or 110 links	.. each 6/4
25/C340l/401	4' 8" or 112 " "	" 6/4
25/C340m/402	4' 9" or 114 " "	" 6/4
25/C340n/403	4' 10" or 116 " "	" 6/4
25/C340r/404 1/2	5' 0" or 120 " "	" 6/4

Twin Roller.

1" x 3/8". No. 111059.
5' 0" or 60 links .. each 10

For Carrier.

No. 25/C344r/606
No. 25/C350m/609 1/2" x 3/8" x 4' 9" or 114 links (112045) each 9/-

"THE COVENTRY" BLOCK CHAIN

With Bolt and Nut Fastening.

1" x 3/8". No. 135041.

No. 25/C344r/3702 .. 5' 0" or 60 links .. each 55/9

PRICES shown do NOT include PURCHASE TAX which will be charged at current rates where applicable

Branches
Aberdeen, Aston, Belfast
Birmingham, Bournemouth
Bristol, Cardiff, Carlisle
Croydon, Dublin, Exeter
Leeds, Liverpool, London
Manchester, Newcastle
Nottingham, Oxford, Preston
Reading, Southampton
Sheffield, Stockport
Tyneside, Wakefield

Head Office and Warehouse, Wholesale only

GREAT EASTERN STREET, LONDON, E.C.2

128 GEORGE STREET EDINBURGH, 1

Branches
Liverpool, Manchester
Newcastle-upon-Tyne
Nottingham, Oxford, Preston
Reading, Southampton
Sheffield, Stockport
Tyneside, Wakefield

CHAINS—continued

**"B.S.A." CYCLE CHAIN**

With Patent "S" Fastening.

No. 25/C331d/502 $\frac{1}{2}$ " pitch \times $\frac{1}{4}$ " \times 4' 9" or 114 links each 6/6**"THE COVENTRY" CHAIN TO SUIT AUTOCYCLES**

With Spring Clip Fastening.

 $\frac{1}{2}$ " pitch \times $\frac{1}{4}$ " \times 5' or 120 links (112045).

No. 25/C351r/600 each 9/2

**"YELLOWOREX" COURSE DERAILLEUR CYCLE CHAINS**Specially suitable for all Derailleur gears using $\frac{1}{2}$ " sprockets.

(Made in France by Peugeot.)

 $\frac{1}{2}$ " \times $\frac{1}{4}$ " \times 114 links.

No. 25/C379d/804 each 14/-

BRAMPTON DERAILLEUR CYCLE CHAINS

(Made in France.)

 $\frac{1}{2}$ " \times $\frac{1}{4}$ " \times 120.Specially suitable for Four-Speed Derailleur Gears with $\frac{1}{2}$ " Sprockets.

No. 25/C355/910 (No. E300d) each 14/9

**"THE COVENTRY" SPRING LINKS**

For old pattern "Coventry" Chains.

With large diameter rivets.

(No. 26 for 111048.)

No. 25/C424a/204 $\frac{1}{2}$ " \times $\frac{1}{4}$ " per doz. 3/11

(No. 26 for 111049.)

No. 25/C424b/204 $\frac{1}{2}$ " \times $\frac{1}{4}$ " per doz. 3/11

For Trade Carrier Chain.

(No. 26 for 112045.)

No. 25/C424c/204 $\frac{1}{2}$ " \times $\frac{1}{4}$ " per doz. 3/11**"RENOLD-ELITE" SPRING LINKS**

(No. 26 for 111044.)

No. 25/C424d/204 $\frac{1}{2}$ " \times $\frac{1}{4}$ " per doz. 3/11

(No. 26 for 111046.)

No. 25/C424e/204 $\frac{1}{2}$ " \times $\frac{1}{4}$ " per doz. 3/11**PERRY SPRING LINKS**

No. 6 with Thin Pins.

No. 25/C425k/204 $\frac{1}{2}$ " \times $\frac{1}{4}$ " per doz. 3/1125/C425l/204 $\frac{1}{2}$ " \times $\frac{1}{4}$ " .. 3/11

For Carrier Cycle Chain.

No. 25/C425m/310 $\frac{1}{2}$ " \times $\frac{1}{4}$ " per doz. 6/6**CHAIN SPRING LINKS**

Special Line.

For $\frac{1}{2}$ " pitch \times $\frac{1}{4}$ " chain, fitted with thin pins.

Suitable for all standard cycle chains.

No. 25/C428a/111 .. per doz. 3/-

**PERRY BEST BLUE CYCLE CHAIN**

With Thin Pin Spring-Clip Fastening

 $\frac{1}{2}$ " \times $\frac{1}{4}$ " No. 51308. $\frac{1}{2}$ " \times $\frac{3}{8}$ " No. 51908.No. 25/C354a/400 $\frac{1}{2}$ " pitch \times $\frac{1}{4}$ " \times 4' 6" or 108 links each 6/425/C354b/400 $\frac{1}{2}$ " .. \times $\frac{1}{4}$ " \times 4' 7" or 110 6/425/C354c/401 $\frac{1}{2}$ " .. \times $\frac{1}{4}$ " \times 4' 8" or 112 6/425/C354d/401 $\frac{1}{2}$ " .. \times $\frac{1}{4}$ " \times 4' 9" or 114 6/425/C354e/402 $\frac{1}{2}$ " .. \times $\frac{1}{4}$ " \times 4' 10" or 116 6/425/C354g/404 $\frac{1}{2}$ " .. \times $\frac{1}{4}$ " \times 5' 0" or 120 6/425/C354m/401 $\frac{1}{2}$ " .. \times $\frac{1}{4}$ " \times 4' 9" or 114 6/425/C354n/402 $\frac{1}{2}$ " .. \times $\frac{1}{4}$ " \times 4' 10" or 116 6/425/C354r/404 $\frac{1}{2}$ " .. \times $\frac{1}{4}$ " \times 5' 0" or 120 6/4**PERRY CARRIER CYCLE CHAIN**

With Spring Clip Fastenings. No. 141908.

No. 25/C359i/506 $\frac{1}{2}$ " pitch \times $\frac{1}{4}$ " \times 4' 7" or 110 links each 9/225/C359m/509 $\frac{1}{2}$ " .. \times $\frac{1}{4}$ " \times 4' 9" or 114 9/225/C359r/600 $\frac{1}{2}$ " .. \times $\frac{1}{4}$ " \times 5' 0" or 120 9/2**"ELIOS-ALPHA" CYCLE CHAIN** $\frac{1}{2}$ " pitch \times $\frac{3}{8}$ " wide \times 114 links, specially suitable for Derailleur 3, 4, or 5 speed gears. Straw colour finish side plates with loose plate and rivet end (as a spring clip link or bolt and nut fitting would foul on free wheel).

Made in Italy.

No. 25/C378d/1004 each 18/6

**"THE COVENTRY" INNER LINKS**

(No. 4 for 111048.)

No. 25/C437f/9 $\frac{1}{2}$ " \times $\frac{1}{4}$ " per doz. 1/2

(No. 4 for 111049.)

No. 25/C437g/9 $\frac{1}{2}$ " \times $\frac{1}{4}$ " per doz. 1/2**"RENOLD-ELITE" INNER LINKS**

(No. 4 for 111044.)

No. 25/C436f/9 $\frac{1}{2}$ " \times $\frac{1}{4}$ " per doz. 1/2

(No. 4 for 111046.)

No. 25/C436g/9 $\frac{1}{2}$ " \times $\frac{1}{4}$ " per doz. 1/2**SPRING CLIPS ONLY**"RENOLD" $\frac{1}{2}$ " pitch. No. 27. 

(No. 27 for 11048-49.)

No. 25/C449a/3 per doz. -/5

PERRY $\frac{1}{2}$ " pitch. No. 7.

No. 25/C449p/3 per doz. -/5

CHAIN BOLTS AND NUTS.To suit "Perry" $\frac{1}{2}$ " \times $\frac{1}{4}$ " chain.

Special Line.

No. 25/C398a/6 per doz. 9/-

25/C398s/500 gross —

**"THE COVENTRY" CRANKED**

DOUBLE LINKS

(No. 30 for 111048.)

No. 25/C438a/201 $\frac{1}{2}$ " \times $\frac{1}{4}$ " per doz. 3/1

(No. 30 for 111049.)

No. 25/C438b/201 $\frac{1}{2}$ " \times $\frac{1}{4}$ " per doz. 3/1

(No. 30 for 112045.)

 $\frac{1}{2}$ " \times $\frac{1}{4}$ " for Trade Carrier Chain.

No. 25/C438c/209 per doz. 4/1

"RENOLD-ELITE"

CRANKED DOUBLE LINKS

Complete with spring link.

(No. 30 for 111044.)

No. 25/C440f/209 $\frac{1}{2}$ " \times $\frac{1}{4}$ " .. each 4/1

(Nos. 30 for 111046.)

No. 25/C440g/209 $\frac{1}{2}$ " \times $\frac{1}{4}$ " .. each 4/1**PERRY CRANKED DOUBLE LINKS,**

No. 10

No. 25/C439a/201 $\frac{1}{2}$ " \times $\frac{1}{4}$ " per doz. 3/125/C439b/201 $\frac{1}{2}$ " \times $\frac{1}{4}$ " .. 3/1

For Carriers.

No. 25/C439c/209 $\frac{1}{2}$ " \times $\frac{1}{4}$ " per doz. 4/1

PRICES shown do NOT include PURCHASE TAX which will be charged at current rates where applicable

Branches
Aberdeen, Acton, Belfast
Birmingham, Bournemouth
Bristol, Cardiff, Carlisle
Croydon, Dublin, Dundee
Exeter, Glasgow
Hull, Ipswich, Leeds

Head Office and Warehouse, Wholesale only.

GREAT EASTERN STREET, LONDON, E.C.2

124 GEORGE STREET EDINBURGH, 2

Branches
Liverpool, Newcastle
Newcastle-upon-Tyne
Nottingham, Oxford, Preston
Reading, Southampton
Sheffield, Tinsley
Wolverhampton

CHAIN RIVET EXTRACTORS, ADJUSTERS AND PUNCHES

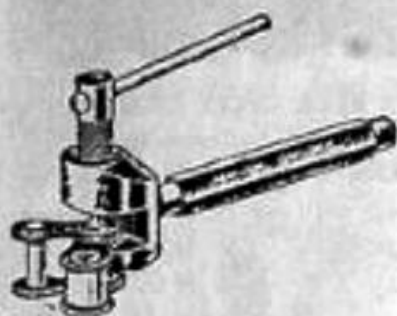
**"KING DICK"****CHAIN RIVET EXTRACTOR**For Cycle Chains $\frac{1}{8}$ ", $\frac{3}{16}$ " or $\frac{1}{4}$ " wide.

(No. C1.)

No. 25/C480k/308 each 4/11

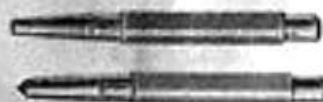
**PENNANT HARDENED STEEL
CENTRE AND PIN PUNCHES**

Size 4" x 1".

No. 25/C486/1105 per doz. 15/2

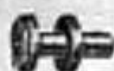
**"CAM" CHAIN HOOK**With $\frac{3}{16}$ " centre pin to brass into frames, unplated.

"Cyclo."

No. 25/C471/7 per doz. 1/-

"Chater-Lea"

No. 25/C470/9 per doz. 1/-

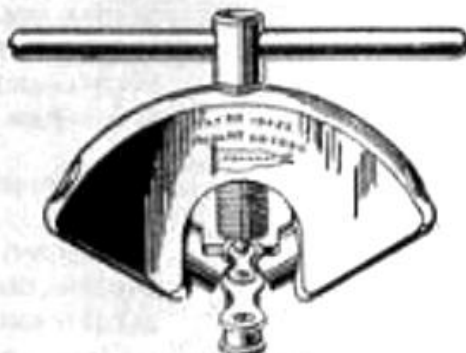
**PENNANT
CHAIN RIVET EXTRACTOR**

Compact, strongly made, simple in construction and use. Instantly removes links from any bicycle, motor cycle or light car chain.

No. 25/C480p/403 each 5/8

Self Adjusting.

No. 25/C480s/511 each 7/11

**"THE COVENTRY" CYCLE CHAIN
RIVET EXTRACTOR (No. 311500)**

Complete with detachable push-in punch.

No. 25/C480c/401 each 5/5

Push-in punches only for above.

No. 25/C480f/2 each 3/-

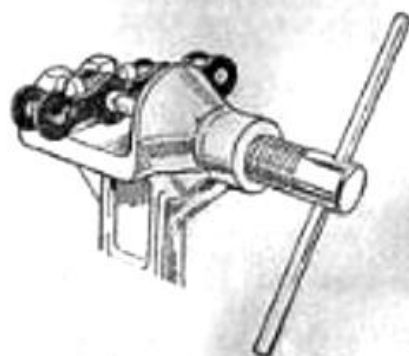
**"PIFON" RIVET EXTRACTOR**
Specially suitable for $\frac{3}{8}$ " cycle chain,
Continental Make.

No. 25/C480w/508 each 8/6

**STANDARD "BBL" CHAIN
ADJUSTERS** $\frac{1}{4}$ " hole, $\frac{1}{2}$ " stem, British Made.

With closed end caps. Cadmium Plated.

No. 25/C501f/400 per doz. pairs 6/-

**CYCLO CHAIN RIVET
EXTRACTOR**Duplex type, with two punches to push both rivets through side plate to suit $\frac{1}{2}$ " pitch chain.

No. 25/C480g/1000 each 15/-

**CYCLO TRUE TRACK CHAIN
ADJUSTER**

Cadmium Plated.

No. 25/C503t/8 per pair 1/-

PRICES shown do NOT include PURCHASE TAX which will be charged at current rates where applicable

Branches:
Aberdeen, Acton, Bolton,
Birmingham, Bourneville,
Bristol, Cardiff, Carlisle,
Croydon, Dublin, Dundee,
Lacka, Glasgow,
Sheff. Inverness, Leeds

Head Office and Warehouse, Wholesale only:

GREAT EASTERN STREET, LONDON, E.C.2

136 GEORGE STREET EDINBURGH, 2

Branches:
Exeter, Gloucester,
Harrow, Ipswich,
Leeds, London, Luton,
Manchester, Newcastle,
Nottingham, Oxford, Peterborough,
Reading, Southampton,
Tottenham, Wakefield,
Wolverhampton

CHAIN ADJUSTERS CHAIN COVERS



PHILLIPS CHAIN ADJUSTERS

On cards of 1 dozen pair M9-LX.

Cadmium Plated.

No. 25/C506p/308 card 5/6

For
OIL BATH
GEAR CASES
see page
80



"ROSA" REAR WHEEL CHAIN ADJUSTERS OR STOPS

For use with "Cyclo" Two- or Three-speed Chain Gears for instantaneous adjustment.

On show cards of 1 dozen pairs. No. 74.

No. 25/C518r/10 per pair 1/2
25/C518r/904 doz pair



MIDLAND CHAIN COVERS

Black Enamelled, with open front.

For 19 1/2" centres for 44 T. wheels. No. 105.

No. 25/C728a/404 each 6/6

For 19 1/2" centres for 48 T. wheels. No. 106.

No. 25/C728b/404 each 6/6



"VINDEC" METAL TOP CHAIN GUARDS

Black Enamelled, with clips for 1 1/2" down tube.

22 1/2" long for 26" or 28" wheels.

For Roadster Cycles.

With "D" Chain Stay Clips

No. 25/C730w/108 each 2/6
25/C730w/1906 per doz. —

With Round Clip

No. 25/C730x/108 each 2/6
25/C730x/1906 per doz. —

Black Enamelled and Lined.

With "D" Chain Stay Clips.

No. 25/C730e/200 each 3/-
25/C730e/2306 per doz. —
25/C730f/200 each 3/-
25/C730f/2306 per doz. —

With 1/2" Round Clips for Sports Cycles.

No. 25/C730g/200 each 3/-
25/C730g/2306 per doz. —
25/C730h/200 each 3/-
25/C730h/2306 per doz. —



MIDLAND METAL TOP CHAIN GUARDS

Plain, Black Enamelled. For 16" wheels.

With 1/2" round clip. No. 153.

No. 25/C730m/200 each 3/-

With "D" Clip. No. 160

No. 25/C730r/200 each 3/-

TOP CHAIN GUARD CLIPS

Suitable for 25/C730 range of Guards.

Black Enamelled. Sets of two clips with bolts and nuts.

No. 25/C745a/6 For "D" Chain Stays per set -9
25/C745b/6 For "R.D." Chain Stays -9



MIDLAND METAL TRICYCLE CHAIN COVERS

Plain, Black Enamelled, with clips for round fitting.

11 1/2" long x 5 1/2" at chainwheel. No. 143.

No. 25/C735f/200 each 3/-

12 1/2" long x 5 1/2" at chainwheel. No. 148.

No. 25/C735g/200 each 3/-



"CYCLOP" CHAIN WHEEL GUARD

This neat device clips on the outside of the chain wheel and protects the rider's trousers from the chain, without the necessity for trouser clips; the ideal fitting for the business rider. Very simple to fit.

Suitable for all standard 46 and 48 T. chain wheels.

Polished Alloy.

No. 25/C738d/200 each 3/9

PRICES shown do NOT include PURCHASE TAX which will be charged at current rates where applicable

Branches:
Aberdeen, Acton, Belfast
Birmingham, Bournemouth
Bristol, Cardiff, Carlisle
Coventry, Dublin, Dundee
Exeter, Glasgow
Hull, Ipswich, Leeds

Head Office and Warehouse, Wholesale only:

GREAT EASTERN STREET, LONDON, E.C.2

126 GEORGE STREET EDINBURGH. 2

Branches:
Liverpool, Manchester
Newcastle-upon-Tyne
Nottingham, Oxford, Prague
Reading, Southampton
Sheffield, Tinsley
Wolverhampton

CHAIN WHEELS AND CRANKS



NICKLIN 5-Screw Pattern
Joggled $\frac{1}{2}$ " pitch \times $\frac{1}{4}$ " wide. With $6\frac{1}{2}$ " Cranks.

Complete with Cotters.
Chromium Plated.

Without Gear Case Clearance.		
No. 25/C1000e/1203	44 T.	18/6
25/C1000f/1203	46 T.	18/6
25/C1000g/1203	48 T.	18/6
With Gear Case Clearance.		
No. 25/C1001e/1203	44 T.	18/6
25/C1001f/1203	46 T.	18/6
25/C1001g/1203	48 T.	18/6

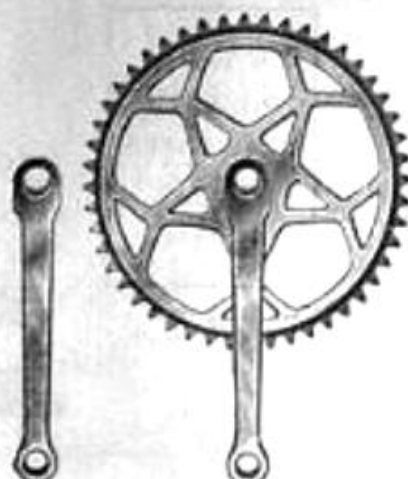

**NICKLIN DOUBLE FLANGED
FIXED PATTERN CARRIER**

With heavy toughened Cranks.

All Black $\frac{1}{2}$ " \times $\frac{1}{4}$ " wide.

Complete with Cotters.

No.	With Gear Case Clearance.	per set
25/C1014e/1309	44 T. \times $6\frac{1}{2}$ " crank	20/8
25/C1014g/1309	48 T. \times 7" ..	20/8



NICKLIN FIXED PATTERN

"Joggled" $\frac{1}{2}$ " pitch \times $\frac{1}{4}$ " wide.

Complete with Cotters.

Chromium Plated.

Without Gear Case Clearance.		
With $6\frac{1}{2}$ " cranks.		
No. 25/C1025e/1009	44 T.	per set 16/2
25/C1025f/1009	46 T.	" 16/2
25/C1025g/1009	48 T.	" 16/2
With 7" Cranks.		
No. 25/C1025n/1009	48 T.	per set 16/2
With Gear Case Clearance.		
With $6\frac{1}{2}$ " Cranks.		
No. 25/C1026e/1009	44 T.	per set 16/2
25/C1026f/1009	46 T.	" 16/2
25/C1026g/1009	48 T.	" 16/2
With 7" Cranks.		
No. 25/C1026n/1009	48 T.	per set 16/2



**NICKLIN
DIRECT DRIVE TANDEM SETS OF
CHAIN WHEELS AND CRANKS**

$6\frac{1}{2}$ " Cranks, complete with Cotters.

Chromium Plated $\frac{1}{2}$ " pitch \times $\frac{1}{4}$ " wide.

Front, 42 T. Rear, 42 T. and 48 T.

No. 25/C1050g/3400 .. per set 51/-



**CYCLO "JUVENILE" CHAIN
WHEEL AND CRANKS**

Die-cast in steel grey polychromatic finish.
22 T. \times $\frac{1}{2}$ " \times $\frac{1}{4}$ ". 4" fixed right-hand crank
to suit $\frac{1}{2}$ " axle and $\frac{1}{2}$ " cotters, and for $\frac{1}{8}$ "
pedals (sans cotters).

No. 25/C1046/500 .. per set 7/6

For pedals to suit see List No. 25/P298.



NICKLIN JUVENILE SET

36 T. \times $5\frac{1}{2}$ " Crank. $\frac{1}{2}$ " pitch \times $\frac{1}{4}$ " wide.

Complete with Cotters.

Chromium Plated.

With Gear Case Clearance.

No. 25/C1033k/1009 .. per set 16/2



**NICKLIN FOR FAIRY
CYCLES**

Juvenile Chain Wheel and Oval Cranks.

Complete with Cotters.

Chromium Plated.

$\frac{1}{2}$ " pitch \times $\frac{1}{4}$ " wide. To suit $\frac{1}{8}$ " Pedals.

For $\frac{1}{2}$ " Axle and $\frac{1}{2}$ " Cotters.

No.	With Gear Case Clearance.	per set
25/C1041b/809	28 T. \times 4"	13/2
25/C1041f/503	32 T. \times 4 $\frac{1}{2}$ "	14/-

PRICES shown do NOT include PURCHASE TAX which will be charged at current rates where applicable

Branches:
Aberdeen, Aston, Belfast
Birmingham, Blackburn
Bristol, Cardiff, Chelsea
Croydon, Dublin, Dundee
Edinburgh, Glasgow
Hull, Liverpool, Leeds

Head Office and Warehouse, Wholesale only:

GREAT EASTERN STREET, LONDON, E.C.2

116 GEORGE STREET EDINBURGH, 3

Branches:
Liverpool, Manchester
Newcastle-upon-Tyne
Nottingham, Oxford, Preston
Reading, Southampton
Sheffield, Tynes
Wolverhampton

CHAIN WHEELS AND CRANKS—continued

**NICKLIN TRIANGULAR
3-ARM PATTERN**

Without inside flange. $\frac{1}{2}$ " pitch \times $\frac{1}{4}$ " wide
with $6\frac{1}{2}$ " square fluted cranks.
Complete with Cotters.

Chromium Plated.

No. 25/C1055f/2006 46 T. per set 30/9

**NICKLIN 3-ARM STANDARD
CHAINWHEEL SETS**

(Similar to above but less triangular
design.)

Without inside flange. $\frac{1}{2}$ " pitch \times $\frac{1}{4}$ " wide
with $6\frac{1}{2}$ " square fluted cranks.

Complete with Cotters.

Chromium Plated.

No. 25/C1055e/1800 44 T. per set 27/-

25/C1055f/1800 46 T. .. 27/-

25/C1055g/1800 48 T. .. 27/-

BRAMPTON JUVENILE SETS

Fixed Pattern "Joggled" Chromium
Plated.

$\frac{1}{2}$ " \times $\frac{1}{4}$ ". Complete with Cotters.

For $\frac{1}{2}$ " Crank Cotter, $\frac{1}{2}$ " B.B. Axle and
 $\frac{3}{8}$ " pedals. (All Standard Sizes)

With Gear Case Clearance.

No. 25/C1065b/811 22 T. \times 4" per set
No. 517 13/6

25/C1065e/811 28 T. \times 4" No. 505 13/6

25/C1065k/1009 36 T. \times 5 $\frac{1}{2}$ " No. 501 16/-

**CHATER LEA FLANGED CHAIN
WHEEL SETS**

3-Arm Pattern. New Design. Square
Fluted Cranks.
Chromium Plated.

Cranks $6\frac{1}{2}$ " without G.C.C. Complete with
Cotter.
 $\frac{1}{2}$ " pitch \times $\frac{1}{4}$ " wide.

Without "CL." Regd. Design
Chain Wheel.

38 T.

No. 25/C1109b/5701 .. per set 78/9

40 T.

No. 25/C1109c/5701 .. 78/9

With "C.L." Regd. Design
Chain Wheel.

$\frac{1}{2}$ " Pitch \times $\frac{3}{8}$ " wide.

46 T.

No. 25/C1108f/3903 .. per set 81/9

48 T.

No. 25/C1108g/5907 $\frac{1}{2}$.. 82/3

$\frac{1}{2}$ " Pitch \times $\frac{1}{4}$ " wide.

42 T.

No. 25/C1109d/5705 $\frac{1}{2}$.. per set 79/3

44 T.

No. 25/C1109e/5710 .. 79/9

46 T.

No. 25/C1109f/5802 .. 80/3

48 T.

No. 25/C1109g/5906 $\frac{1}{2}$.. 80/9

50 T.

No. 25/C1109h/5903 .. 81/9

52 T.

No. 25/C1109k/6000 .. 82/9

**CHATER LEA CHAIN WHEELS
ONLY**

Please see Page 55.

3-ARM CRANKS

Please see Page 56.

**BRAMPTON CHAIN WHEELS
AND CRANKS**

Fixed Pattern "Joggled"
Chromium Plated.

$\frac{1}{2}$ " \times $\frac{1}{4}$ " Complete with Cotter.
Standard Sets. Model 501.
Without Gear Case Clearance.

46 T. \times $6\frac{1}{2}$ "
No. 25/C1060/1009 .. per set 16/-

48 T. \times $6\frac{1}{2}$ "
No. 25/C1060/1009 .. per set 16/-

48 T. \times 7"
No. 25/C1060/1009 .. per set 16/-

52 T. \times 7"
No. 25/C1060/1104 .. per set 17/-

With Gear Case Clearance.

44 T. \times $6\frac{1}{2}$ "
No. 25/C1061/1009 .. per set 16/-

48 T. \times $6\frac{1}{2}$ "
No. 25/C1061/1009 .. per set 16/-

48 T. \times 7"
No. 25/C1061/1009 .. per set 16/-

**B.S.A. FLANGED CHAINWHEEL
AND CRANKS**

5-screw fixing. Best Quality.

$\frac{1}{2}$ " pitch \times $\frac{1}{4}$ " wide. Less Cotter.

Fluted Square Cranks, coloured red on Fluting
Chromium Plated. 46 T.

No. 25/C1074f/2708 .. per set 35/9

PRICES shown do NOT include PURCHASE TAX which will be charged at current rates where applicable

Branches
Aberdeen, Arson, Belfast
Birmingham, Burnsmouth
Bristol, Cardiff, Carlisle
Croydon, Dublin, Dundee
Eastbourne, Glasgow
Hull, Ipswich, Leeds

Head Office and Warehouse, Wholesale only:

GREAT EASTERN STREET, LONDON, E.C.2

134 GEORGE STREET EDINBURGH. 3

Branches
Liverpool, Manchester
Newcastle-upon-Tyne
Nottingham, Oxford, Preston
Reading, Southampton
Sheffield, Wolverhampton

CHAIN WHEELS AND CRANKS—continued

**WILLIAMS UTILITY
CHAIN WHEEL AND CRANKS**

5-Screw Fixing.

 $\frac{1}{2}$ " pitch \times $\frac{1}{4}$ " wide, 6 $\frac{1}{2}$ " Cranks.

Complete with Cotters

Chromium Plated.

"Joggled."

Without Gear Case Clearance.

No. 25/C1126e/1203	44 T.	per set	18/6
25/C1126f/1203	46 T.	"	18/6
25/C1126g/1203	48 T.	"	18/6

With Gear Case Clearance.

No. 25/C1127e/1203	44 T.	per set	18/6
25/C1127f/1203	46 T.	"	18/6
25/C1127g/1203	48 T.	"	18/6

Flanged.

Without Gear Case Clearance.

No. 25/C1128e/1306	44 T.	per set	20/3
25/C1128f/1306	46 T.	"	20/3
25/C1128g/1306	48 T.	"	20/3

With Gear Case Clearance.

No. 25/C1129e/1306	44 T.	per set	20/3
25/C1129f/1306	46 T.	"	20/3
25/C1129g/1306	48 T.	"	20/3

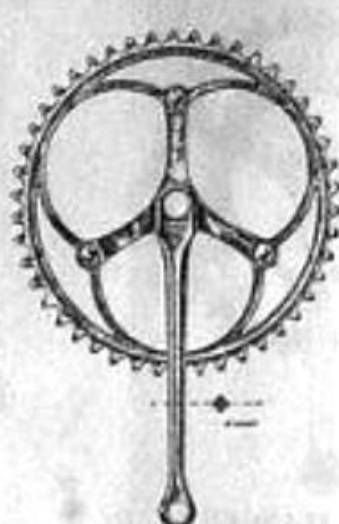
**"GRANBY" CHAIN WHEEL
SETS**
These Sets have been withdrawn
by the Manufacturers.GRANBY CHAIN WHEELS ONLY
are still available. Please refer to
page 55
**"DURAX" CONTINENTAL
LIGHTWEIGHT DOUBLE FLANGED
CHAIN WHEELS AND CRANKS**

3-Arm Pattern.

Nickel Chrome Steel with 4 Flutes.

Less Cotters.

Weight per set, 24 oz.

46 T. \times $\frac{1}{2}$ " \times $\frac{1}{4}$ " \times 6 $\frac{1}{2}$ "	
No. 25/C1148e/4304	per set 65/-
48 T. \times $\frac{1}{2}$ " \times $\frac{1}{4}$ " \times 6 $\frac{1}{2}$ "	
No. 25/C1148e/4304	per set 65/-

**"SCANDIA" CHAIN WHEELS
AND CRANKS**

3-Screw Fixing.

 $\frac{1}{2}$ " Pitch \times $\frac{1}{4}$ " wide, 6 $\frac{1}{2}$ " Fluted Cranks.

(Continental Make.)

Chromium Plated.

No. 25/C1149f/3301 $\frac{1}{2}$	46 T.	per set	49/8
25/C1149g/3301 $\frac{1}{2}$	48 T.	"	49/8

**WILLIAMS B100 BEST QUALITY
CHAIN WHEEL AND CRANKS**

Double Flanged. 5-Screw Fixing.

 $\frac{1}{2}$ " pitch \times $\frac{1}{4}$ " wide, 6 $\frac{1}{2}$ " Cranks.

Complete with Cotters.

Chromium Plated.

Without Gear Case Clearance.

No. 25/C1132e/1409	44 T.	per set	22/3
25/C1132f/1409	46 T.	"	22/3
25/C1132g/1409	48 T.	"	22/3

With Gear Case Clearance.

No. 25/C1133e/1409	44 T.	per set	22/3
25/C1133f/1409	46 T.	"	22/3
25/C1133g/1409	48 T.	"	22/3

For Chain Wheels supplied without Inside
Flange.

-8 Chromium Plated .. Extra 1/-

Double Flanged Carrier Sets.

With extra heavy and toughened Straight
Crank, 50 per cent. stronger, specially suitable
for Carrier Cycles. Complete with Cotters. $\frac{1}{2}$ " pitch \times $\frac{1}{8}$ " wide.

All Black.

No. With Gear Case Clearance, per set

44 T. \times 6 $\frac{1}{2}$ "

25/C1144e/1407 Cranks 21/9

48 T. \times 7"

25/C1144g/1407 .. 21/9

**WILLIAMS B100 LIGHTWEIGHT
RACING CHAIN WHEEL SET**
5-Screw Fixing. $\frac{1}{2}$ " pitch \times $\frac{1}{4}$ " wide 6 $\frac{1}{2}$ "

Lightweight Cranks. Complete with Cotters.

Less Inside Flange.

Without Gear Case Clearance.

Chromium Plated.

No. 25/C1140e/	44 T.	per set	
25/C1140f/	46 T.	"	
25/C1140g/	48 T.	"	

PRICES shown do NOT include PURCHASE TAX which will be charged at current rates where applicable

Branches
Aberdeen, Aston, Belfast
Birmingham, Bournemouth
Bristol, Cardiff, Carlisle
Croydon, Dublin, Dundee
Exeter, Glasgow
Hull, Ipswich, Leeds

Head Office and Warehouse, Wholesale only:

GREAT EASTERN STREET, LONDON, E.C.2
125 GEORGE STREET EDINBURGH 2

Branches
Liverpool, Manchester
Newcastle-upon-Tyne
Nottingham, Oxford, Preston
Reading, Southampton
Sheffield, Tyneside
Wolverhampton

CHAIN WHEELS AND CRANKS—continued



**WILLIAMS B109 DUREEL
SUPER LIGHTWEIGHT CHAIN
WHEEL SETS**

With Narrow Inside Flange and Extra Light Cranks. 5-Screw Fixing. 6½" Cranks. Complete with Cotters.

Chromium Plated.

Without Gear Case Clearance.

½" pitch × ½" wide.

Weight 1 lb. 2 oz. to 1 lb. 4 oz.

No. 25/C1142e/4000	44 T.	per set	60/-
25/C1142f/4000	46 T.	..	60/-
25/C1142g/4000	48 T.	..	60/-



**C.B. LIGHT ALLOY CHAIN
WHEEL SETS**

3-Arm Pattern. Double flanged, with Fluted Steel Cranks.

Chain Wheel made of toughened non-aluminium alloy and highly polished.

Cranks made from carbon steel forgings—usually 40/50 ton.

Chromium Plated. Without Cotters.

46 T. × ½" × ½" × 6½". Cranks with Flutes lined red. British made. Weight 31½ oz.

No. 25/C1153c/2505 .. per set 38/6



**WILLIAMS G34 FLANGED
CHAIN WHEEL AND CRANKS**

3-Arm Pattern. ½" pitch × ½" wide. With 6½" Cranks. Complete with Cotters.

Without Inside Flange, without Gear Case Clearance.

Chromium Plated.

No. 25/C1155e/1500	44 T.	per set	22/6
25/C1155f/1500	46 T.	..	22/6
25/C1155g/1500	48 T.	..	22/6



**WILLIAMS G1200, FLANGED
CHAIN WHEELS AND CRANKS**

3-Arm Pattern, weight 1 lb. 9 oz., for 46 T. Set. Complete with Cotters.

Chromium Plated.

½" pitch × ½" wide. Without Inside Flange. Cranks made of high tensile steel and heat treated and with outside single flute.

44 and 46 T.

No. 25/C1160/ .. per set



**WILLIAMS G1000 LIGHT-
WEIGHT RACING CHAIN WHEEL
SET**

3-Arm Pattern. ½" pitch × ½" wide with 6½" Cranks, complete with Cotters.

Less Inside Flange without Gear Case Clearance.

Chromium Plated.

No. 25/C1158e/	44 T.	per set	
25/C1158f/2200	46 T.	..	33/-
25/C1158g/	48 T.	..	



**WILLIAMS F27 BEST QUALITY
DOUBLE FLANGED CHAIN WHEEL
SET**

Specially suitable for Carrier Cycles.

Fixed Pattern. ½" pitch × ½" wide.

6½" Crank. Complete with Cotters.

With Gear Case Clearance. Black Finish.

No. 25/C1167e/1303	44 T.	per set	19/11
25/C1167f/1303	46 T.	..	19/11
25/C1167g/1303	48 T.	..	19/11

PRICES shown do NOT include PURCHASE TAX which will be charged at current rates where applicable

Branches
Aberdeen, Aston, Belfast
Birmingham, Bournemouth
Bristol, Cardiff, Carlisle
Croydon, Dublin, Dundee
Exeter, Glasgow,
Hull, Ipswich, Lamb

Head Office and Warehouses, Wholesale only:

GREAT EASTERN STREET, LONDON, E.C.2

128 GEORGE STREET EDINBURGH, 2

Branches
Sheepcot, Manchester
Newcastle-upon-Tyne
Nixonington, Oxford, Preston
Reading, Southampton
Sunderland, Walsingham

CHAIN WHEELS ONLY CHAIN WHEEL DERAILLEURS

CHATER LEA 3-ARM CHAIN WHEELS ONLY
(Less Screws). $\frac{1}{2}$ " pitch \times $\frac{1}{2}$ " wide.
Chromium Plated.

Without "CL" Registered Design Pattern.

No. 25/C1220a/1010	36 T. . .	each 15/-
25/C1220b/1010	38 T. 15/-
25/C1220c/1010	40 T. 15/-

"CL" Registered Design Pattern.

No. 25/C1228d/1102	42 T. . .	each 15/6
25/C1228e/1107	44 T. 16/-
25/C1228f/1111	46 T. 16/6
25/C1228g/1204	48 T. 17/-
25/C1228h/1300	50 T. 18/-
25/C1228k/1309	52 T. 19/-

"DURAX" 3-ARM CHAIN WHEELS ONLY

 $\frac{1}{2}$ " \times $\frac{1}{2}$ ".

Chromium Plated.

No. 25/C1373f/1300	46 T. . .	each 19/6
25/C1373g/1300	48 T. 19/6

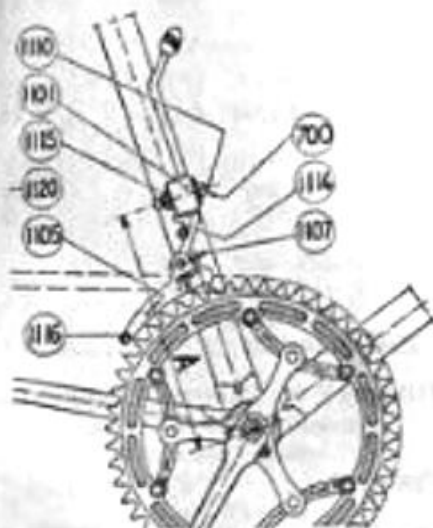
"SIMPLEX" DOUBLE DERAILLEUR CHAIN WHEELS ONLY
(3-Arm Pattern. Less Cranks.) $\frac{1}{2}$ " pitch \times $\frac{3}{8}$ " wide, 46/49 T.

49 T. in Chromium plated steel and 46 T. in blued steel. Continental Make.

No. 25/C1371a/2608 each 40/-

(See No. 25/C1534 for cranks to suit above chain wheels.)

"SIMPLEX" CHAIN WHEEL DERAILLEUR ONLY

Specially designed for use with Simplex double chain wheels.

Seat tube lever control with two $\frac{1}{2}$ " clips with specially designed detaining cage to prevent chain jumping off chain wheels. Continental Make.

No. 25/C1372a/1804 each 27/6



WILLIAMS D34 DIRECT-DRIVE TANDEM CHAIN WHEELS ONLY.

3-Arm Pattern.

Chromium Plated. $\frac{1}{2}$ " pitch \times $\frac{1}{2}$ " wide.

Front Chain Wheels only.

No. 25/C1368b/1008 42 T. . . each 16/-

Inside Drum Chain Wheels only.

No. 25/C1369b/1008 42 T. . . each 16/-

Outside Chain Wheels only.

No. 25/C1369m/1000 44 T. . . each 15/-

25/C1369n/1000 46 T. 15/-

25/C1369p/1000 48 T. 15/-

25/C1369r/1000 52 T. 15/-

42 T. and 44 T. combined.

No. 25/C1370b/ each

42 T. and 46 T. combined.

No. 25/C1370c/ each

42 T. and 48 T. combined.

No. 25/C1370h/ each

42 T. and 52 T. combined.

No. 25/C1370m/ each

"GRANBY" LIGHT ALLOY CHAIN WHEELS ONLY

3-Arm Fixing

 $\frac{1}{2}$ " Pitch \times $\frac{1}{2}$ " wide. Double Flanged.
Polished Finish.

No. 25/C1264f/908 46 T. . . each 14/6

25/C1264ft/908 47 T. 14/6

25/C1264g/908 48 T. 14/6

Polished and Coloured Fluting.

(Red, Blue, Green and Black.)

No. 25/C1265g/1000 48 T. . . each 15/-

"CHATER LEA" DURALUMIN ADAPTERS, FOR TANDEM CHAIN WHEELS with 3 long Chromium Bolts.

No. 25/C1230c/709 $\frac{1}{2}$.. each 10/9

Bolts only for above.

Chromium Plated.

No. 25/C1230n/501 .. per doz. 7/-

WILLIAMS 3-ARM CHAIN WHEELS ONLY

Without Inside Flange.

With 3 Screws fitted. Chromium Plated.

 $\frac{1}{2}$ " pitch \times $\frac{1}{2}$ " wide. (C1000).

No. 25/C1349e/603 44 T. . . each 9/6

25/C1349f/603 46 T. 9/6

25/C1349g/603 48 T. 9/6

 $\frac{1}{2}$ " pitch \times $\frac{1}{2}$ " wide. (C34).

No. 25/C1361e/506 44 T. . . each 8/3

25/C1361f/506 46 T. 8/3

25/C1361g/506 48 T. 8/3

NICKLIN 3-ARM CHAIN WHEELS ONLY

Without inside flange. With 3 screws fitted. $\frac{1}{2}$ " pitch \times $\frac{1}{2}$ " wide.

Chromium Plated.

No. 25/C1261e/603 44 T. . . each 9/6

25/C1261f/603 46 T. 9/6

25/C1261g/603 48 T. 9/6

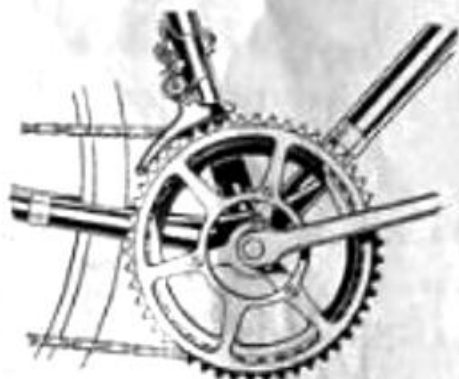

CYCLO BENELUX DOUBLE CHAIN WHEEL SHIFTER

(Handlebar Control.)

Chain shifter with clip for fitment to seat tube and cycle handlebar trigger control.

For $\frac{1}{2}$ " \times $\frac{1}{2}$ " Chain Wheel.

No. 25/C1371a/2000 each 30/-

For $\frac{1}{2}$ " \times $\frac{3}{8}$ " Chain Wheel.

No. 25/C1371b/2000 each 30/-

CYCLO "ROSA" DOUBLE CHAIN WHEELS

(Complete with Cranks.)

3-arm fixing. $\frac{1}{2}$ " pitch. $\frac{3}{8}$ " wide.

Chromium Plated.

Size of wheels 46 T.-49 T.

No. 25/C1372a/ per set

Size of wheels 47 T.-50 T.

No. 25/C1372b/ per set

PRICES shown do NOT include PURCHASE TAX which will be charged at current rates where applicable.

Branches
Aberdeen, Arson, Belfast
Birmingham, Bournemouth
Bristol, Cardiff, Cardiff
Croydon, Dublin, Dundee
Exeter, Glasgow
Full Street, Leeds

Head Office and Warehouse, Whitehall only:

GREAT EASTERN STREET, LONDON, E.C.2

121 GEORGE STREET EDINBURGH. 3

Branches
Liverpool, Manchester
Newcastle-upon-Tyne
Nottingham, Oxford, Preston
Reading, Southampton
Stoke-on-Trent
Wolverhampton

CHAIN WHEELS ONLY AND DERAILLEURS CHAIN WHEEL CRANKS



**"HURET" DOUBLE DERAILLEUR
CHAIN WHEELS ONLY**
(3-Arm.)

$\frac{1}{2}$ " pitch \times $\frac{1}{8}$ " wide, 50 T. chromium plated steel, and 47 T. forged duralumin and polished chain wheels.

French manufacture. To fit Continental cranks.

No. 25/C1371h/2500 .. per set 37/6



**"HURET" CHAIN WHEEL
DERAILLEUR CONTROL**

Specially designed for use with "Huret" double chain wheels. Seat tube lever control with $1\frac{1}{2}$ " clip. Made in die cast alloy and polished.

French manufacture. Less Chain Wheels.

No. 25/C1372h/1804 .. each 27/6

**"HURET" COMBINED DERAILLEUR
CHAIN WHEEL AND GEAR CONTROL**

Specially designed for use with "Huret" double chain wheels. Cable control complete with Dual Levers for chain wheel and Derailleur Gear Control. Down tube fitting.

French manufacture. Less Chain Wheels.

No. 25/C1372k/1908 .. each 29/-



RIGHT-HAND WHEEL CRANKS
5-Screw Fixing $\frac{1}{8}$ " \times 20 R.H.T. Chromium Plated.

Without Gear Case Clearance

"B.S.A." Double Fluted (Fluting Coloured Rod). Less Cotter.
No. 25/C1409m/1000 6 $\frac{1}{2}$ " .. each 14/-

"Nicklin." (With Cotter.)
No. 25/C1401m/504 6 $\frac{1}{2}$ " .. each 8/-

"Williams." Best Quality. (With Cotter.)
No. 25/C1411m/503 6 $\frac{1}{2}$ " .. each 9/6
25/C1411p/503 7" 9/6

Williams "Utility." (With Cotter.)
No. 25/C1414m/501 6 $\frac{1}{2}$ " .. each 7/8
25/C1414p/501 7" 7/8

"Williams" B1100. Lightweight. Complete with Cotters.
No. C1417m/ 6 $\frac{1}{2}$ " .. each

With Gear Case Clearance.

"Nicklin." (With Cotter.)
No. 25/C1421m/504 6 $\frac{1}{2}$ " .. each 8/-

"Williams." Best Quality. (With Cotter.)
No. 25/C1431m/503 6 $\frac{1}{2}$ " .. each 9/6
25/C1431p/503 7" 9/6

Williams "Utility." (With Cotter.)
No. 25/C1424m/501 6 $\frac{1}{2}$ " .. each 7/8
25/C1424p/501 7" 7/8

"Williams." Toughened for Carriers. All Black. (Less Cotter.)
No. 25/C1433m/504 6 $\frac{1}{2}$ " .. each 9/6
25/C1433p/504 7" 9/6



RIGHT-HAND WHEEL CRANKS

3-Arm Pattern (Screw fixing). $\frac{1}{8}$ " \times 20 R.H.T. Complete with Cotters.

"Nicklin." (Single Fluting.)
No. 25/C1442m/505 6 $\frac{1}{2}$ " .. each 12/9

"Williams" C34 Pattern.
No. 25/C1445m/507 6 $\frac{1}{2}$ " .. each 9/11

"Williams" C1000 Pattern.
No. 25/C1452m/507 6 $\frac{1}{2}$ " .. each 9/11

"Williams" B109. Lightweight for Dural Sets. Chromium Plated.
No. 25/C1460m/ 6 $\frac{1}{2}$ " .. each

Durax (Continental). Fluted. (Less Cotter.)
No. 25/C1426m/1608 6 $\frac{1}{2}$ " .. each 25/-

Chater Lea. Square Fluted Pattern.
No. 25/C1436m/3010 6 $\frac{1}{2}$ " R.H.T. each 42/6



PLAIN LEFT-HAND CRANKS

$\frac{1}{8}$ " \times 20 L.H.T. Chromium Plated.

"Nicklin." Plain. (With Cotter.)

No. 25/C1471h/309 5 $\frac{1}{2}$ " .. each 5/8
25/C1471m/309 6 $\frac{1}{2}$ " 5/8
25/C1471p/309 7" 5/8

"Nicklin." For Juvenile. (With Cotter.) For $\frac{1}{4}$ " axle and $\frac{1}{4}$ " Cotter.

No. 25/C1476e/ 4" each
25/C1476f/ 4 $\frac{1}{2}$ "

"Nicklin." Best Quality Fluted. (With Cotter.)

No. 25/C1472m/605 6 $\frac{1}{2}$ " .. each 6/9

"B.S.A." Fluted (Fluting Coloured Rod). Less Cotter.
No. 25/C1484m/505 6 $\frac{1}{2}$ " .. each 12/6

"Chater Lea."

Square Fluted. (With Cotter.)

No. 25/C1502m/1505 6 $\frac{1}{2}$ " .. each 21/3

Williams "Utility." (With Cotter.)
No. 25/C1508m/307 6 $\frac{1}{2}$ " .. each 5/6
25/C1508p/307 7" 5/6

"Williams" Best Quality. (With Cotter.) For B100 and C34.

No. 25/C1511m/502 6 $\frac{1}{2}$ " .. each 7/9

"Williams" for "Dural" Lightweight and C1000 Set. (With Cotter.)

No. 25/C1522m/ 6 $\frac{1}{2}$ " .. each

"Durax" (Continental)

Fluted. (Less Cotter.)

No. 25/C1526m/1208 6 $\frac{1}{2}$ " .. each 19/-

"Williams." For Carrier.

All Black. Toughened. (With Cotter.)

No. 25/C1514m/503 6 $\frac{1}{2}$ " .. each 7/11
25/C1514p/503 7" 7/11

"DURAX" 3-ARM CRANKS
(Continental)

Left- and Right-hand Cranks in pairs for Simplex Double Chain Wheels. Less Cotters. Complete with screws. Chromium Plated.

No. 25/C1534/3108 6 $\frac{1}{2}$ " per pair 47/6

PRICES shown do NOT include PURCHASE TAX which will be charged at current rates where applicable

Branches:
Aberdeen, Accrington, Belfast
Birmingham, Blackburn
Bristol, Cardiff, Carlisle
Croydon, Dublin, Dundee
Glasgow, Leicester, London
Newcastle, Nottingham

Head Office and Warehouse, Wholesale only

GREAT EASTERN STREET, LONDON, E.C.2
125 GEORGE STREET EDINBURGH, 2

Branches:
Liverpool, Manchester
Newcastle-upon-Tyne
Nottingham, Oxford, Preston
Reading, Southampton
Sheffield, Tynes
Wolverhampton

CRANK SUNDRIES—continued. CYCLE ERECTORS



CRANK DRAWER

Will remove tight Cranks without damage to Crank, Pin or Plating. (No. MA.123.)

No. 25/C1581a/800 each

CYCLO
DOUBLE-ENDED CRANK TAP

Right- and Left-hand Thread combined with Reamer at both ends.

$\frac{1}{4}$ " x 24 thread. Less Tommy Bar.
(No. 125.)

No. 25/C1582L/1200 each

CYCLO DOUBLE-ENDED
CYCLE CRANK TAP

Right- and Left-hand Thread combined.
 $\frac{1}{4}$ " x 20 thread.

Less Tommy Bar. (No. 125.)

No. 25/C1582m/800 each

CYCLO CRANK
REAMER

Tapered $\frac{1}{4}$ " for Bracket
Spindle Clearance.

(No. 106.)

No. 25/C1585/900 each

"B.B.L." CRANK BENDING IRON
(Wringing Iron.)

For twisting and straightening Cranks, etc.
Made from Steel with machined openings.

No. 25/C1580a/1008 each

CYCLO
CYCLE CRANK TAP-
PING AND BUSHING
SET FOR PEDAL
BUSHING

For re-bushing the pedal end of worn cycle cranks, thus prolonging the life of many cranks, the pedal spindle being held very rigid in the thread provided by the bush. Set of 2 taps and 6 bushes for each right- and left-hand threads.

No. 25/C1582a/1406 per set

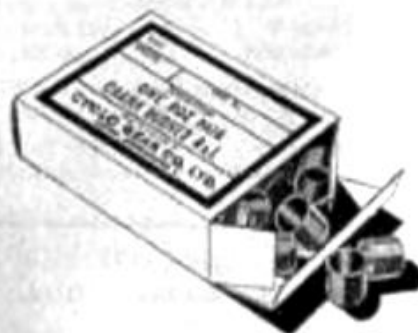
CYCLO CRANK PEDAL BUSHES
Right and Left.

In boxes of one dozen pairs. (No. 125B.)

No. 25/C1582d/206 Right Hand doz. 4/-
25/C1582e/206 Left Hand .. 4/-



CYCLO CRANK PEDAL TAPS

$\frac{1}{4}$ " dia. x 20 threads. (British Made.)

Right Hand.

No. 25/C1583a/211 Taper .. each
25/C1583b/211 Plug

Left Hand.

No. 25/C1583c/211 Taper .. each
25/C1583d/211 Plug

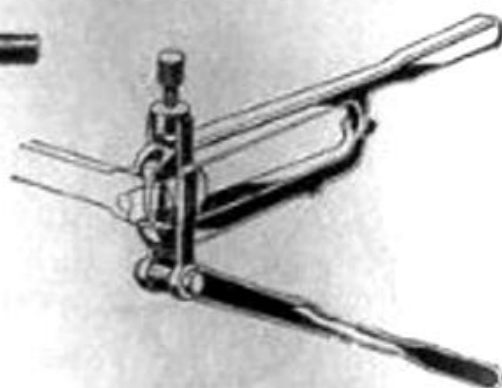
CYCLO CRANK COTTER
EXTRACTOR OR FITTER

For fitting or removing Crank Cotters without damaging head or thread. Milled head adjustment gives rapid universal use. (No. 147.)

No. 25/C1581c/2600 each

For PEDAL SPANNERS
see under "SPANNERS"



"B.B.L."

CYCLE ERECTORS

Will hold cycle rigid at any angle, and at any height. All parts easily detached for packing. Fitted with felt-lined jaws. (No. MA.64.)

No. 25/C1692a/10811 each

PRICES shown do NOT include PURCHASE TAX which will be charged at current rates where applicable

Branches
Aberdeen, Ayr, Belfast
Birmingham, Blackburn
Bristol, Cardiff, Carlisle
Croydon, Dundee, Dundee
Eastbourne, Glasgow
Hull, Ipswich, Leeds

Head Office and Warehouse, Wholesale only

GREAT EASTERN STREET, LONDON, E.C. 2

124 GEORGE STREET EDINBURGH, 2

Branches
Liverpool, Manchester
Newcastle-upon-Tyne
Nottingham, Oxford, Preston
Reading, Southampton
Sheffield, Trent
Wolverhampton

FITTINGS AND FRONT FORKS (Built up)



BRAMPTON'S "SNIPE" SPORTS LUG SETS

Cotterless Low Bracket model for various sizes.

Pressed Lugs, for $1\frac{1}{4}$ " tubes and 1" parallel top tubes for $\frac{1}{2}$ " chain stay, $\frac{1}{2}$ " seat stays.

COMPRISING:

No. 880 129	Crown Lug	Standard "D"	No. 840 050	Seat Lug	$1\frac{1}{4}$ " x 1" x 71"
820 054	Top Lug	$1\frac{1}{4}$ " x $1\frac{1}{4}$ " x 73"	830 218	B.B. Shell	$1\frac{1}{4}$ " x $1\frac{1}{4}$ " x $1\frac{1}{4}$ " x $1\frac{1}{4}$ " Cl. x 63" x 63"
820 150	Bottom Lug	$1\frac{1}{4}$ " x $1\frac{1}{4}$ " x 71"	BSE. 120	Stay Eyes to suit	$\frac{1}{2}$ " Round Spearpoints

For Gent's Machines.

No. 25/F86c/1101
No. 25/F86b/704Feature Cutaway .. per set --
Plain --FRONT FORKS
SPORTS PATTERN

Built up with Best Quality 13 G. Batted Head Stems, "D" to Round Blades with 3" rake and Round solid ends. New Girder pattern Crown and Brazed-on Mudguard eyes.

For 26" Wheels.

Screwed down 4", 1" x 24 thread.
9 1/2" StemBest Black Enamelled with
Chromium Plated Crown.

No. 25/F319c/1708 per pair 26/6

All Chromium Plated.

No. 25/F319g/2508 per pair 38/6

FRONT FORKS
SPORTS PATTERN

Built up with Best Quality 13 G. Batted Head Stems, "D" to round fork blades with pressed ends.

New Girder Pattern Crown,
brazed-on Mudguard EyesScrewed down 4", 1" x 24 thread
10" Stem. For 26" Wheels.

Black Enamelled.

No. 25/F336/904 per pair 14/-

Black Enamelled with Chromium
Plated Crown.

No. 25/F336c/1108 per pair 17/6

All Chromium Plated.

No. 25/F336g/1911
per pair 29/10"EKLA" FRAME LUGS
(Continental Make)

A set of cast lugs, guaranteed to conform to standard British sizes to built up frames with head angle of 73° and seat angle of 71°. Set comprises bottom bracket, seat lug (with stay eyes), top and bottom head lugs, cut-away as illustrated above.

No. 25/F150t/1006 .. per set --

With Plain Lugs.

No. 25/F150w/900 .. per set --

For Crowns see No. 25/F430 range on
Page 71.

For
CYCLE FRAMES
Please refer to the
CYCLE SECTION
of this Catalogue.

FRONT FORKS
ROADSTER PATTERNBuilt up with Best Quality 13 G. Batted Head Stems, D Forks with pressed ends. New Girder Pattern Crown. Screwed 4" down
1" x 24 thread

Best Black Enamelled.

With 9" Stem for 24" Wheel.
No. 25/F332a/804 per pair 12/6With 10" Stem for 26" Wheel.
No. 25/F332e/804 per pair 12/6With 10" Stem for 28" Wheel.
No. 25/F334e/804 per pair 12/6With 12" Stem for 28" Wheel.
No. 25/F334h/804 per pair 12/6Black Enamelled with Chrome
Plated CrownWith 10" Stem for 26" Wheel.
No. 25/F333e/1008 per pair 16/-

JUNIOR FRONT FORKS

Built up with Plain Head Stems,
D Forks with slotted ends. Best
Black Enamelled. Pressed Crown.8 1/2" Stems. Screwed down 2"
1" x 24 thread.

No. 25/F361c/606 .. per pair

For 14" Wheels 10/-

25/F361f/607 .. 16" .. 10/-

25/F361k/609 .. 18" .. 10/-

25/F361n/609 .. 20" .. 10/-

PRICES shown do NOT include PURCHASE TAX which will be charged at current rates where applicable

Branches
Aberdeen, Acton, Belfast
Birmingham, Bournemouth
Bristol, Cardiff, Carlisle
Croydon, Dublin, Dundee
Exeter, Glasgow
Hull, Ipswich, Leeds

Head Office and Warehouse, Wholesale only.

GREAT EASTERN STREET, LONDON, E.C. 2

136 GEORGE STREET, EDINBURGH, 1.

Branches
Liverpool, Manchester
Newcastle-upon-Tyne
Nottingham, Oxford, Preston
Reading, Southampton
Sheffield, Tynes
Wolverhampton

FORK CROWNS—continued FORK ENDS, ETC.

**"ELKA" (CONTINENTAL MAKE)
DROPPED FORGED STEEL FORK CROWNS**
Machined and cut away.



For Standard Oval Blades.

No. 25/F430f/700 each 10/6

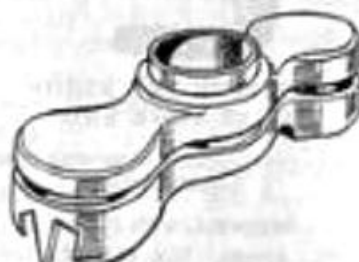

For 1/2" Round Blades.

No. 25/F430b/806 each 14/3

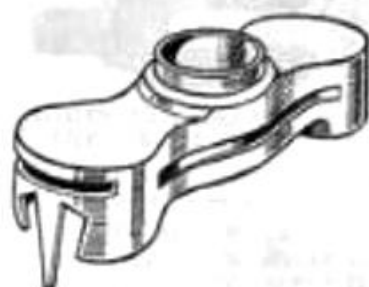

For Standard "D" Blades.

No. 25/F430d/703 each 12/-



**CYCLO FORK CROWN REAMER
OR RACE CUTTER**

Split adjustable.

To fit over head stem and collar or shoulder of crown, for removing all surplus metal after brazing column to crown. Leaves a perfect surface to receive the crown race.

Reamer or cutter complete with standard head die holder.

No. 25/F450b/2900 each —

Reamer or cutter only, less holder.

No. 25/F450c/1706 each —



FRONT FORK ENDS

With Round Ends to enter 1/8" dia. Fork Blades.

Machined special Angle Slots to suit 1/8" Spindles.

No. 25/F541w/103 Offset per pair 1/8
25/F541w/1406 doz. pair —

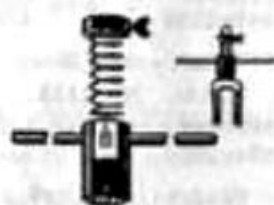

"VAR" FORK CROWN REAMER

No. 7. Continental Make.

A simple but robust tool which slips over the head stem and collar or shoulder of crown, and removes all surplus metal after brazing column to crown. Leaves a perfect surface to receive the crown race. Reamer is double sided, to suit either British or Metric size tubes.

No. 25/F450L/15000 each —



CYCLO FRONT FORK ENDS

1/8" opening with Mudguard Eye.
No. 154.

No. 25/F543/100 per pair 1/6



BRAMPTON FRONT FORK ENDS

Machined and slotted 1/8", hole 1/8" and Plain Ends.

For Round End Forks.

With Mudguard Eye. No. 860201.

No. 25/F537d/104 per pair 2/-

Without Mudguard Eye. No. 860200.

No. 25/F537a/102 per pair 1/8



STALLARD FRONT FORK ENDS

For front. Machined for use with 0-350 fork blades with Mudguard Eye.

No. 25/F542/105 per pair 2/2



BRAMPTON REAR FORK ENDS
(No. 860220)

"Drop-Out" Pattern, Plain

With loose chain stay ends, and loose bottom stay ends.

No. 25/F587L/201 per pair 3/2

PRICES shown do NOT include PURCHASE TAX which will be charged at current rates where applicable

Branches
Aberdeen, Aston, Belfast
Birmingham, Bournemouth
Bristol, Cardiff, Carlisle
Croydon, Dublin, Dundee
Exeter, Glasgow
Hull, Ipswich, Leeds

Head Office and Warehouse, Wholesale only

GREAT EASTERN STREET, LONDON, E.C.2

134 GEORGE STREET EDINBURGH, 2

Branches
Liverpool, Manchester
Newcastle-upon-Tyne
Nottingham, Oxford, Preston
Reading, Southampton
Sheffield, Tinsley
Wolverhampton

FORK ENDS—continued FRAME TUBES, ETC.



CHATER LEA RIGID
REAR FORK ENDS

Ordinary slotted, with loose stay eyes
(less adjuster).

Cycle. No. 684-3.

No. 25/F591a/110 .. per pair 2/6
25/F591a/2100 .. doz. pair —

Blades only for No. 684-3.

Less stay eyes.

No. 25/F591/71 .. per pair —/10
25/F591/703 .. doz. pair —



STALLARD REAR FORK ENDS

With long front prong. For Osgear and
Cyclo Ace Derailleur gears.

No. 25/F606a/108 .. per pair 2/6



STALLARD REAR FORK ENDS

With offset mudguard eye, without long
prong for Simplex and Cyclo Olympic and
Benslux Type Derailleur gears.

No. 25/F606c/108 .. per pair 2/3



CYCLO "ROSA" IMPROVED
FORK EXPANDER

Simple and effective. (No. 133)

No. 25/F660g/806 .. each 9/9



CHATER LEA RIGID
REAR FORK ENDS

Forward opening, with loose stay eyes, non-
adjuster type.

Serrated, with 1/2" slots.

Cycle. No. 1553-1.

No. 25/F591r/110 .. per pair 2/6
No. 25/F591r/2109 .. doz. pair —

Tandem. No. 939-3.

No. 25/F591s/110 .. per pair 2/6
25/F591s/2109 .. doz. pair —

Plain, with 1/2" slots

Cycle. No. 1553.

No. 25/F591t/108 .. per pair 2/4
25/F591t/2000 .. doz. pair —

Tandem. No. 939-2.

No. 25/F591w/110 .. per pair 2/6
25/F591w/2109 .. doz. pair —

Blades only.

For No. 1553-1 Fork Ends.

Serrated.

No. 25/F591k/71 .. per pair —/10
25/F591k/703 .. doz. pair —

Plain.

No. 25/F591m/8 .. per pair —/8
25/F591m/809 .. doz. pair —



FORK END
SCREWS

Square Head.

Size 3/8" x 3/8" x 32 thread.

Nickel Plated.

No. 25/F632a/5 .. per doz. —/8



FORK END SCREWS

Nickel Plated.

Hexagon Head.

Size: 3/8" x 1" x 32 thread.

No. 25/F634a/100 .. per doz. 1/6



CYCLO REAR FORK ENDS

Double Purpose Fork Ends. Ref. No. 17

Suitable for all types of Sports frames.

No. 25/F606c/100 .. per pair 1/1



CYCLO REAR FORK ENDS

Continental Fork Ends with Chain Sp.

With 1/2" slots for flattened spindles No. 153

No. 25/F606e/100 .. per pair 1/1

With 1/2" slots for round spindles.

No. 25/F606f/100 .. per pair 1/1



"A. & P." WELDLESS STEEL ROUND
FRAME TUBES

18 Gauge Straight Plain Gauge Tube
Bright Finish.

1" dia. x 24" long

No. 25/F700b/109 .. each 2/6

1 1/4" dia. x 24" long.

No. 25/F701b/110 .. each 2/6

20 Gauge Straight Plain Gauge Tube
Bright Finish.

1" dia. x 24" long

No. 25/F702b/109 .. each 2/6

1" dia. x 24" long

No. 25/F703b/109 .. each 2/6

1 1/4" dia. x 24" long.

No. 25/F704c/109 .. each 2/6

1 1/4" dia. x 24" long.

No. 25/F712p/110 .. each 2/6

PRICES shown do NOT include PURCHASE TAX which will be charged at current rates where applicable

Branches
Aberdeen, Accrington, Belfast,
Birmingham, Bradford,
Bristol, Cardiff, Carlisle,
Croydon, Dublin, Dundee,
Exeter, Glasgow,
Hull, Ipswich, Leeds

Head Office and Warehouse, Wholesale only

GREAT EASTERN STREET, LONDON, E.C.2

124 GEORGE STREET EDINBURGH, 2

Branches
Liverpool, Manchester,
Newcastle-upon-Tyne,
Nottingham, Oxford, Preston,
Reading, Southampton,
Sheffield, Tyneside,
Wolverhampton

FRAME TUBE LUGS FREE WHEELS



"B.B.L." LADY'S SLOPING TOP
TUBE AND SEAT TUBE LUG
SPORTS MODEL

Non-parallel Top and Down Tube.
Malleable Castings. Plain. $1\frac{1}{2}'' \times \frac{1}{2}'' \times 77''$.
No. 25/F984c/102 each 1/9

BRAMPTON

Top tube parallel to bottom tube.
Plain pressed. $1\frac{1}{2}'' \times \frac{1}{2}''$. 67" or 113".
No. 25/F986a/102 each 1/9



BRAMPTON
TOP BACK STRUT FRAME TUBE LUG
For Lady Back Tandem or Double Diamond
Top Back Strut Tube.

$1\frac{1}{2}'' \times 1\frac{1}{2}'' \times 64''$ for 20 $\frac{1}{2}''$. (No. 830669)
No. 25/F998x/9 Fish-tailed .. each 1/1



"B.S.A." FREE WHEELS

$\frac{1}{2}''$ Pitch.

No. 25/F1260g/308 18 T. $\times \frac{1}{2}''$ each 5/-

CYCLO

STANDARD FREE WHEELS

$\frac{1}{2}''$ pitch $\times \frac{1}{2}''$ wide.

No.	each
25/F1282g/500	18T. 7/6
25/F1282h/502	19T. 7/9
25/F1282k/504	20T. 8/-
25/F1282l/506	21T. 8/3
25/F1282m/508	22T. 8/6
25/F1282n/510	23T. 8/9
25/F1282p/500	24T. 9/-
25/F1282r/502	25T. 9/3
25/F1282s/504	26T. 9/6
25/F1282w/506	28T. 9/9



No. 25/F1285c/1200 each 18/-

CYCLO
TRIPLE
FREE WHEEL
With universal flush
back.

$\frac{1}{2}'' \times \frac{1}{2}''$.

1st Gear: 19, 20,
21 and up to
28 T.
2nd Gear: 17 to
24 T.
3rd Gear: 16, 17T.

BRAMPTON
REAR SEAT TUBE
FRAME LUGS

For Central Stay
Model Tandems.

$1\frac{1}{2}'' \times 1\frac{1}{2}'' \times 82''$.
(No. 830690.)

No. 25/F998L/8 Plain .. each 1/-

BRAMPTON FRONT CROSS
FRAME LUG

$1\frac{1}{2}'' \times 1\frac{1}{2}''$ for Central Stay Model
Tandem. (No. 830680.)

No. 25/F998f/9 Plain .. each 1/1



"T.D.G." MINIATURE FREE WHEELS

14 T., $\frac{1}{4}''$ pitch $\times \frac{1}{4}''$.

$1'' \times 20$ Thread.

Plain Bearing.

No. 25/F1247c/204 each 3/6



"B.W." FREE WHEELS

$\frac{1}{2}''$ Pitch.

No. 25/F1253g/309	18 T. $\times \frac{1}{2}''$	each 5/3
25/F1253k/309	20 T. $\times \frac{1}{2}''$.. 5/3
25/F1254g/310	18 T. $\times \frac{3}{8}''$.. 5/5
25/F1254k/310	20 T. $\times \frac{3}{8}''$.. 5/5

"T.D.C." ALL BALL BEARING FREE
WHEEL

$\frac{1}{2}''$ Pitch.

No. 25/F1275g/309	18 T. $\times \frac{1}{2}''$	each 5/1
25/F1275k/309	20 T. $\times \frac{1}{2}''$.. 5/1
25/F1275m/403	22 T. $\times \frac{1}{2}''$.. 5/7
25/F1276g/310	18 T. $\times \frac{3}{8}''$.. 5/2
25/F1276k/310	20 T. $\times \frac{3}{8}''$.. 5/2

CYCLO
TWO-SPEED
FREE WHEELS

For use with "Cyclo"
Two-speed Chain Gears.

$1'' \times 1''$.



Sizes:

Free Wheel, 16 and 17 T.

Sprockets, 18, 19, 20, 21, 22, 23, 24, 25 and
26 T.

No. 25/F1284c/800 Complete .. each 12/-
Free Wheel, less Low Gear Sprocket
No. 25/F1284f/409 each 7/2

CYCLO TRIPLE FREE WHEELS

Standard pattern. $\frac{1}{2}'' \times 1''$.

1st Gear: 18 to 26 and 28 T.

2nd Gear: 17 to 19 T.

3rd Gear: 13 to 16 T.

Complete.

No. 25/F1290e/1200 each 18/-

Less 2nd and 3rd sprockets.

No. 25/F1290f/700 each 10/6

PRICES shown do NOT include PURCHASE TAX which will be charged at current rates where applicable

Branches
Aberdeen, Ayr, Belfast
Birmingham, Bournemouth
Bristol, Cardiff, Carlisle
Croydon, Dublin, Dundee
Exeter, Glasgow
Hull, Ipswich, Leeds

Head Office and Warehouse, Wholesale only:

GREAT EASTERN STREET, LONDON, E.C. 2

126 GEORGE STREET EDINBURGH 3

Branches
Liverpool, Manchester
Newcastle-upon-Tyne
Nottingham, Oxford, Preston
Reading, Southampton
Sheffield, Tyneside
Wolverhampton

FREE WHEEL REMOVERS—continued



"VAR" FREE WHEEL AND CHAIN WHEEL VICE OR HOLDER No. 9.

(Continental Make.)

A simple bench tool which can be used for a variety of jobs, repairing and adjusting Free Wheels, changing sprockets, removing and replacing the Chain Wheel from the crank.

The holding studs engage firmly with the teeth form, securing the Free Wheel or Chain Wheel rigidly, without damage to the teeth, and a steel washer on top of each stud prevents the sprocket jumping out under the strain of removal.

Quickly adjusted to take any teeth from 14 T. to 52 T.

No. 25/F1694m/3500 each



"VAR" UNIVERSAL FREE WHEEL REMOVER No. 5.

(Continental make.)

Length 21½". Weight 2 lb. 14 oz.

A workshop tool with long wood handle, which will remove any type of ordinary or boss pattern Free Wheel.

The tool is made in three parts. The body of tool carries a pair of double ended dogs, one pair of dog ends for fitting into notches of ordinary Free Wheel and the other pair to suit boss pattern Free Wheel.

To use the tool, the body is passed over the hub spindle end, so that the correct pair of dog ends engage in Free Wheel notches.

The plug is screwed on spindle end to lock body into position on Free Wheel, so that dog ends cannot slip out of the notches.

The handle is then used as a spanner with the jaws being passed into the two flats provided on the body, when the long lever handle enables the most stubborn Free Wheel to be removed with ease.

No. 25/F1693x/4500 each



"VAR" FREE WHEEL COG REMOVER No. 10.

(Continental Make.)

With the Free Wheel held in the Vice No. 9 the Cog Remover No. 10 is quickly adjusted to fit the sprocket, which it is desired to remove. The engaging dogs are shaped to the teeth form, and cannot damage the teeth. The long levers enable the most stubborn cogs to be removed quickly and easily.

No. 25/F1694r/2500 each

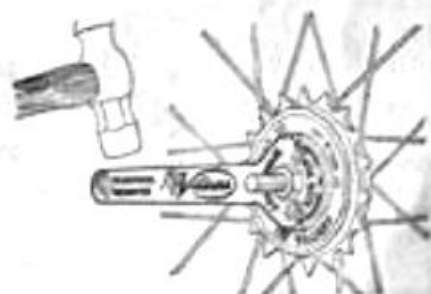

VILLIERS FREE WHEEL REMOVER

For Standard Free Wheel.

No. 25/F1693v/203 each 3/1



CYCLO "ROSA" SPROCKET REMOVER JIG AND FREE WHEEL HOLDER COMBINED

For bolting down to bench.

Sliding adjusting plate with peg for various size sprockets. A most useful tool for the workshop.

No. 25/F1694/1500 No. 143 each

COGS for MULTIPLE FREE WHEELS
please refer to Pages 113 and 114.

PRICES shown do NOT include PURCHASE TAX which will be charged at current rates where applicable

Branches
Aberdeen, Arona, Belfast
Birmingham, Bournemouth
Bristol, Cardiff, Carlisle
Croydon, Dublin, Dundee
Exeter, Glasgow
Hull, Inverness, Leeds

Head Office and Warehouse, Wholesale only:

GREAT EASTERN STREET, LONDON, E.C.2

111 GEORGE STREET EDINBURGH, 2

Branches
Liverpool, Manchester
Newcastle-upon-Tyne
Nottingham, Oxford, Preston
Reading, Southampton
Sheffield, Tynes
Wolverhampton

HANDLES—continued HANDLEBARS AND BENDS



"SHOCKSTOP" PNEUMATIC GRIP No. 69
4 1/2" long, for 1/2" bars.

"SHOCKSTOP" PNEUMATIC
ECCENTRIC HANDLES

- No. 25/H222p/202 Black per pair 3/3
H222p/2504 doz. pair —
25/H222r/206 Red per pair 3/8
H222r/2904 doz. pair —

"NORTH ROAD"
DROPPED
HANDLEBARS

With 1" forward Lug,
3" Drop, 2" forward
Bend.

3/4" top, 3/4" stem, 7" long.
"A. & P." Best Quality
Steel.

Chromium Plated.

- No. 25/H297n/1100 18" wide .. each 17/3



"NORTH ROAD" RAISED
HANDLEBARS

With 1" forward
Lug, 2" raised
Bend.

3/4" top, 3/4" stem,
7" long, 18" wide.

A. & P. Best Quality Steel
Chromium Plated.

- No. 25/H309n/1108 .. each 17/6



ROMAG HANDLEBAR GRIPS

Finger Grip. Moulded Black Rubber 4 1/2".
No. 1379.

- No. 25/H227a/108 .. per pair 2/6

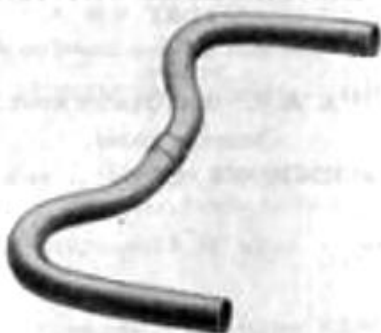

"NORTH ROAD" RAISED
'R' SHAPE STEEL HANDLEBARS

With 1" forward Lug, 3 1/2" raised, 3/4" top,
3/4" stem, 18" wide.

A. & P. "B" Quality Steel
Chromium Plated on Steel.

Less Expander Bolt.

- No. 25/H303n/1501 each 22/6

With Expander Bolt.

- No. 25/H304n/1607 each 25/-

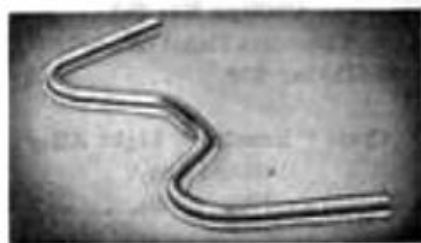

"COMFORT" FLAT
HANDLEBAR BENDS

18" wide, 3/4" dia. with 3/4" Ferrule.

Reynolds H.M. Quality
Chromium Plated on Steel.

- No. 25/H333n/1307 each 20/6

Reynolds Hyduminium RR56

Polished Alloy.

- No. 25/H334xn/803 3/4" dia. .. each 12/4



"COMFORT" SEMI-DROPPED
HANDLEBAR BENDS

17" wide, 1 1/2" dropped, 3/4" dia. with 3/4" Ferrule.

Reynolds H.M. Quality
Chromium Plated on Steel.

- No. 25/H338m/1307 each 20/6

Reynolds Hyduminium RR56

Polished Alloy.

- No. 25/H339xa/803 3/4" dia. .. each 12/4



STADIUM RUBBER HANDLES

No. 103.

Moulded Rubber. 4 1/2" long, for 1/2" bars.
Boxed in Pairs.

- No. 25/H226a/104 Black per pair 2/-
25/H226c/104 Red .. 2/-



PHILLIPS "NORTH ROAD" RAISED
HANDLEBARS

With 1" forward Lug, 3/4" stem, 18" wide.
Chromium Plated on Steel.

- No. 25/H310 804 No. 87 .. each 12/6



PHILLIPS LIGHT TOURIST
HANDLEBARS

With 1" forward Lug, 3/4" stem, 18" wide.
Chromium Plated on Steel.

- No. 25/H311/900 No. 135 .. each 13/6

PRICES shown do NOT include PURCHASE TAX which will be charged at current rates where applicable

Branches
Aberdeen, Aston, Belfast
Birmingham, Bournemouth
Bristol, Cardiff, Carlisle
Croydon, Dublin, Dundee
Exeter, Glasgow, Leeds
Luton, Manchester, Leeds

Head Office and Warehouse, Wholesale only:

GREAT EASTERN STREET, LONDON, E.C.2

124 GEORGE STREET EDINBURGH, 2

Branches
Liverpool, Manchester
Newcastle-upon-Tyne
Nottingham, Oxford, Preston
Reading, Southampton
Sheffield, Stockport
Wolverhampton

HANDLEBAR BENDS—continued



"COMFORT" FULL DROPPED
16½" wide, 3½" dropped, ½" dia. with
¾" ferrule.

Reynolds H.M. Quality
Chromium Plated on Steel.

No. 25/H343L/1307 each 20/6

Reynolds Hiduminium RR56
Polished Alloy.

No. 25/H344xa/302 ½" dia. .. each 12/4

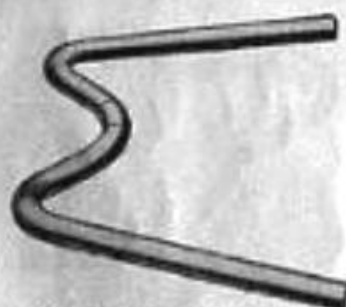

"ANELAY" FLAT PATTERN

½" dia., 2½" forward bend, 22" wide.
½" dia., fitted with ¾" dia. brazed-on plated
ferrule.

"A. & P." Best Quality Steel.

No. 25/H383t/1603 Chromium .. each 15/6



"CONTINENTAL"

½" dia. with ¾" dia. brazed ferrules
6½" drop, 4" forward bend, 18" wide.

"A. & P." Best Quality Steel.

Chromium Plated.

No. 25/H408n/1201 18" wide .. each 18/-

Phillips No. 326

Chromium Plated on Steel.

No. 25/H408np/506 each 9/9

Reynolds Hiduminium RR56

17" wide, ¾" dia.

Polished Alloy.

No. 25/H409xa/1000 each 15/-



"LAUTERWASSER" PATTERN
FLAT

½" dia. fitted with ¾" dia. brazed-on plated
ferrules.

"A. & P." Best Quality Steel.

Chromium Plated.

No. 25/H363h/1002 15" wide .. each 15/6



"ALL ROUNDER"

22" wide, 2" forward, 4" flat centre, 1½" drop.
½" dia. with ¾" raised ferrule.

"A. & P." Best Quality Steel.

Chromium Plated.

No. 25/H393n/800 each 12/-

Phillips No. 368

Chromium Plated on Steel.

No. 25/H393np/600 each 9/-

Cyclo "Roanloy" Light Alloy

Polished Alloy.

No. 25/H394ca/1000 ¾" dia. .. each 15/-

G.B. Polished Alloy

¾" dia. with G.B. ferrule.

No. 25/H394gb/1100 each 16/6

"Stratalite" Polished Alloy

No. 25/H394sa/808 ¾" dia. .. each 13/-

Reynolds Hiduminium RR56

Polished Alloy.

No. 25/H394xa/802 ½" dia. .. each 12/4

"SPRENCHLEY"
FLAT

3" Straight Centre,
20" wide.

½" dia., fitted with
¾" dia. brazed-on
plated ferrule.

"A. & P." Best Quality Steel.
Chromium Plated.

No. 25/H373r/1002 each 15/6



"BAILEY" PATTERN

½" dia. with ¾" ferrule, 4" forward.

"A. & P." Best Quality Steel.
Chromium Plated.

No. 25/H403L/1110 16" wide .. each 17/9

No. 25/H403n/1110 18" 17/9

Phillips No. 803

Chromium Plated on Steel.

No. 25/H403np/806 18" wide .. each 9/9

"Stratalite" Polished Alloy

16" wide, ¾" dia.

No. 25/H404sa/1004 each 15/6

Reynolds Hiduminium RR56

17" wide, ¾" dia.

Polished Alloy.

No. 25/H404xa/808 each 14/6

"ALL ROUNDER" BENDS

SPECIAL LINE

22" wide, ½" dia.
with ¾" raised Ferrule.

Good Quality Steel.

Chromium Plated.

No. 25/H393ne/506 each 5/3

PRICES shown do NOT include PURCHASE TAX which will be charged at current rates where applicable

Branches
Aberdeen, Ayr, Billo
Birmingham, Bournemouth
Bristol, Cardiff, Exeter
Glasgow, Hull, London, Liverpool
Manchester, Newcastle
Newcastle, Nottingham, Plymouth
Reading, Southampton
Sheffield, Tyneside
Wolverhampton

Head Office and Warehouse, Wholesale only:

GREAT EASTERN STREET, LONDON, E.C.2

124 GEORGE STREET EDINBURGH, 1

Branches
Aberdeen, Ayr, Billo
Birmingham, Bournemouth
Bristol, Cardiff, Exeter
Glasgow, Hull, London, Liverpool
Manchester, Newcastle
Newcastle, Nottingham, Plymouth
Reading, Southampton
Sheffield, Tyneside
Wolverhampton

HANDLEBAR BENDS—continued



"A.V.A." SUPER DURA LIGHT ALLOY

Continental Make. (Less stems)

$\frac{3}{8}$ " dia. specially strengthened at the centre where strain is greatest, and with increased section to 1". Polished.

"Criterium"

15" wide, $5\frac{1}{2}$ " drop, 4" forward.

No. 25/H415xc/1404 each 21/6

"Pellissier"

14 $\frac{1}{2}$ " wide, 7" drop, $3\frac{1}{2}$ " forward.

No. 25/H415xr/1404 each 21/6

"Azuren"

15 $\frac{1}{2}$ " wide, 6" drop, 1 $\frac{1}{2}$ " forward.

No. 25/H415xx/1404 each 21/6

"STRATALITE" LIGHT ALLOY HANDLEBAR BENDS

"Tour de France" Pattern.

6 $\frac{1}{2}$ " drop, 4" forward bend.

$\frac{3}{8}$ " dia. x 15" wide.

Polished Alloy.

No. 25/H412sa/1004 each 15/6

"South of France" Pattern

$\frac{3}{8}$ " dia., 15" wide.

Polished Alloy.

No. 25/H412sf/1004 each 15/6

"Madison" Pattern

7 $\frac{1}{2}$ " drop, $3\frac{1}{2}$ " forward bend.

$\frac{3}{8}$ " dia., 15" wide.

Polished Alloy.

No. 25/H413sa/1004 each 15/6

"Dernier" Pattern

5 $\frac{1}{2}$ " drop, 2 $\frac{1}{2}$ " forward bend

$\frac{3}{8}$ " dia., 17" wide.

Polished Alloy.

No. 25/H414sa/1004 each 15/6

"Jean Aerts" Pattern

5 $\frac{1}{2}$ " drop, 2 $\frac{1}{2}$ " forward bend. 15" wide.

Polished Alloy.

No. 25/H415sa/1004 $\frac{3}{8}$ " dia. each 15/6

25/H415ta/1004 1" 15/6

"Mannin Veg" Pattern

6 $\frac{1}{2}$ " drop, 4" forward with straight flat top.

15" wide x $\frac{3}{8}$ " dia.

Polished Alloy.

No. 25/H416sa/1004 each 15/6



"BINDA" PATTERN DROPPED

$\frac{1}{2}$ " dia. fitted with $\frac{3}{8}$ " ferrule.

5 $\frac{1}{2}$ " forward bend, 5 $\frac{1}{2}$ " drop with flat straight centre.

"A. & P." Best Quality Steel.

Chromium Plated.

No. 25/H428n/1106 18" wide .. each 17/3

Phillips No. 807

Chromium Plated on Steel.

No. 25/H428op/606 18" wide .. each 9/9

Reynolds Hiduminium RR56

Polished Alloy.

17" wide, $\frac{3}{8}$ " dia.

No. 25/H429xa/910 each 14/9



"MARSH" PATTERN

5" drop, 5 $\frac{1}{2}$ " forward bend, $\frac{1}{2}$ " dia. with $\frac{3}{8}$ " ferrule.

"A. & P." Best Quality Steel.

Chromium Plated.

No. 25/H478n/1201 18" wide each 18/-

"MARSH" SHALLOW LEVEL PATTERN

Reynolds Hiduminium RR56

3 $\frac{1}{2}$ " drop, 5" forward bend, $\frac{3}{8}$ " dia.

Polished Alloy.

No. 25/H474xa/904 18" wide .. each 14/-

"FLAT"

Ordinary

$\frac{1}{2}$ " dia. fitted with $\frac{3}{8}$ " dia. brazed-on ferrule.

"A. & P." Best Quality Steel.

Chromium Plated.

No. 25/H433n/404 18" wide .. each 6/6



"HIGHGATE"

(Shallow Level Grip)

5 $\frac{1}{2}$ " drop, 5 $\frac{1}{2}$ " forward bend.

$\frac{1}{2}$ " dia. fitted with $\frac{3}{8}$ " dia. brazed-on ferrule.

"A. & P." Best Quality Steel.

Chromium Plated.

No. 25/H448m/1107 17" wide each 17/4

Reynolds Hiduminium RR56

Polished Alloy.

18" wide, $\frac{3}{8}$ " dia.

No. 25/H449xa/906 each 14/3



"LAUTERWASSER" PATTERN DROPPED

$\frac{1}{2}$ " dia., 3 $\frac{1}{2}$ " drop, 5 $\frac{1}{2}$ " forward bend, 15" wide.

"A. & P." Best Quality Steel.

Chromium Plated.

No. 25/H468h/1008 each 15/9

PRICES shown do NOT include PURCHASE TAX which will be charged at current rates where applicable

Branches
Aberdeen, Accrington, Belfast,
Birmingham, Bolton,
Bristol, Cardiff, Carron,
Croydon, Dublin, Dundee,
Eastbourne, Glasgow,
Hull, Inverness, Leeds

Head Office and Warehouse, Wholesale only

GREAT EASTERN STREET, LONDON, E.C.2

128 GEORGE STREET EDINBURGH, 2

Branches
Liverpool, Manchester,
Newcastle-upon-Tyne,
Nottingham, Oxford, Preston,
Reading, Southampton,
Stockport, Tinsley,
Wolverhampton

HANDLEBAR BENDS—continued

HANDLEBAR SUNDRIES

**"MAES" PATTERN**

6 1/2" drop, 3 1/2" forward bend.

1/2" dia. with 3/8" ferrule.

"A. & P." Best Quality Steel.

Chromium Plated.

No. 25/H594b/1110 15" wide .. each 17/9

Phillips No. 804

Chromium Plated on Steel.

No. 25/H594bp/803 16" wide each 9/4

G.B. Light Alloy

3/4" dia. with G.B. ferrule, 15" wide.

Polished Finish.

No. 25/H594gb/1100 each 16/6

"Stratalite" Light Alloy

Polished Finish 3/4" dia., 14 1/2" wide.

No. 25/H594sa/1004 each 15/6

Reynolds High Aluminium RR56

Polished Alloy. 3/4" dia., 14 1/2" wide.

No. 25/H594xa/808 each 14/6

Good Quality Light Alloy**"Maes" Bends**

Polished Finish.

3/4" dia., 15" wide.

No. 25/H594w/808 each 14/6

**"OPPY" PATTERN**

5" drop, 4 1/2" forward bend, 16" wide.

1/2" dia. with 3/8" ferrule.

"A. & P." Best Quality Steel.

Chromium Plated.

No. 25/H613L/1201 each 18/-

**"W" PATTERN FLAT**

1/2" dia. fitted with 3/8" dia. brazed-on plated ferrules.

"A. & P." Best Quality Steel.

Chromium Plated.

No. 25/H603r/808 20 1/2" wide each 13/-

**"ALUMLITE" HANDLEBAR FERRULES**

Alloy Split Section.

Top fancy design 5 1/2" long. Bottom section plain.

For 3/4" Handlebars.

Polished.

No. 25/H645L/104 per pair 2/-

Blue.

No. 25/H645m/108 per pair 2/6

Bronze.

No. 25/H645n/108 per pair 2/6

Gold.

No. 25/H645p/108 per pair 2/6

Green.

No. 25/H645r/108 per pair 2/6

Red.

No. 25/H645s/108 per pair 2/6

For 1/2" Handlebars.

Polished.

No. 25/H645t/104 per pair 2/-

Blue.

No. 25/H645w/108 per pair 2/6

Bronze.

No. 25/H645x/108 per pair 2/6

Gold.

No. 25/H645y/108 per pair 2/6

Green.

No. 25/H645z/108 per pair 2/6

Red.

No. 25/H645aa/108 per pair 2/6

ALLOY HANDLEBAR LINERS

Split to fit over 3/4" handlebars.

No. 25/H645f/300 per doz. pairs 4/6

**DUNLOP HANDLEBAR END STOPS**

Black Rubber End Stops of Plugs for handlebars or bends. Fitted with rustless screw, washer and threaded plate to expand rubber when inserted in end of bar and so prevent pulling out.

No. 25/H646/102 per pair 1/9

**SHOCKSTOP HANDLEBAR PLUGS**

(Reqs. 2 screws 2 1/2" long)

SHOCKSTOP RUBBER HANDLEBAR ENDS

Plugs or Stops.

No. 25/H646r/10 Silver Grey per pair 1/3

25 H646s/10 Black 1/3

25 H646t/10 Red 1/3

25 H646y/10 Beige 1/3

**HANDLEBAR EXPANDER BOLTS**

Complete with cones and washers.

Chromium Plated.

Phillips No. S10-8x.

No. 25/H649b/802 6" long per doz. 13/9

25/H649c/802 8" 13/9

B.B.L.

No. 25/H652b/800 6" long per doz. 12/-

25/H652c/800 8" 13/-

G.B.

No. 25/H653b/1400 6" long per doz. 21/-

For Juvenile.

Phillips No. S10x8k.

No. 25/H647/802 6" long per doz. 13/9

PRICES shown do NOT include PURCHASE TAX which will be charged at current rates where applicable

Branches
Aberdeen, Aston, Belfast
Birmingham, Bournemouth
Bristol, Cardiff, Carlisle
Croydon, Dublin, Dundee
Exeter, Glasgow
Hull, Ipswich, Leeds

Head Office and Warehouse, Wholesale only:

GREAT EASTERN STREET, LONDON, E.C.2

126 GEORGE STREET EDINBURGH, 3

Branches
Greenport, Manchester
Newcastle-upon-Tyne
Nottingham, Oxford, Preston
Reading, Southampton
Sheffields, West
Wolverhampton

HANDLEBAR STEMS (Steel)



2" Forward.

Without Expander Bolt.

No. 1—1" Forward.

No. 25/H700c/1005 1/2" Stem .. each 15/-
 25/H700k/1009 1" 16/-

With Expander Bolt 1/2" Stem.

No. 1—1" Forward.

No. 25/H700d/1107 each 17/4

HANDLEBAR EXPANDER BOLTS

Please see previous page.

"A. & P." STEEL ADJUSTABLE
HANDLEBAR STEMS

Chromium Plated on Best Quality Steel.

8" long x 1/2" to suit bends with 1/2" ferrules.

Complete with lug bolt and nut.

Without Expander Bolt.

No. 2—2" Forward.

No. 25/H703c/1105 1/2" Stem .. each 17/3
 25/H703k/1201 1" 18/-

With Expander Bolt 1/2" Stem.

No. 2—2" Forward.

No. 25/H703d/1211 each 19/6

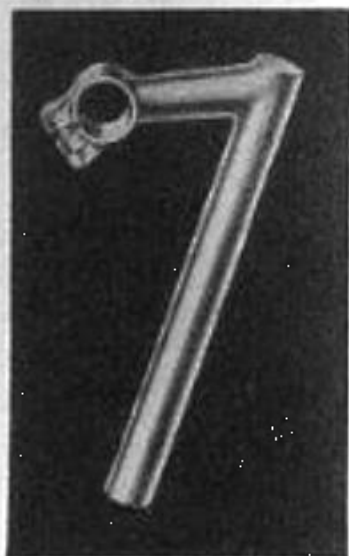

3" Forward.

Without Expander Bolt

No. 3—3" Forward.

No. 25/H704c/1105 1/2" Stem .. each 17/3
 25/H704k/1201 1" 18/-

With Expander Bolt 1/2" Stem.

No. 3—3" Forward.

No. 25/H704d/1211 each 19/6

REYNOLDS
"531" STEEL
ADJUSTABLE
HANDLEBAR
STEMS

Complete with bolt
and nut, 1/2" dia. to
suit bends with 1/2"
dia. ferrules, with
cut-away and fish-
tailed lugs.

Chromium Plated.

Without Expander Bolt.

No.	Forward	each
25/H700t/2009	3 1/2"	31/3
25/H703t/2009	4"	31/3
25/H704t/2106	4 1/2"	32/3

With Expander Bolt.

No.	Forward	each
25/H700w/2211	3 1/2"	34/6
25/H703w/2211	4"	34/6
25/H704w/2308	4 1/2"	35/6

GOOD QUALITY STEEL STEMS

1/2" stem to suit bends with 1/2" dia. ferrules. With bolt and nut

1" Extended Forward

Chromium Plated

Without Expander Bolt

No. 25/H701c/503 .. each 7/9

With Expander Bolt.

No. 25/H701d/511 .. each 8/10

"CLEES" STEEL ADJUSTABLE
HANDLEBAR STEM

Continental Pattern. (British Made)

Complete with lug bolt and nut, 1/2" dia. to suit bends with 1/2" dia. ferrules.

With Expander Bolt.

Chromium Plated.

2 1/2" Curved Extension.

No. 25/H705c/902 each 13/8

HADEN STEEL ADJUSTABLE
HANDLEBAR STEM

Stem 6 1/2" long with pressed clip lug 1 1/2" forward extension complete with bolt, nut and expander bolt

Chromium Plated on Steel.

No. 25/H690/902 each 13/9

PRICES shown do NOT include PURCHASE TAX which will be charged at current rates where applicable

Branches
 Aberdeen, Ayr, Belfast
 Birmingham, Blackburn
 Bristol, Cardiff, Carlisle
 Coventry, Dublin, Dundee
 Exeter, Glasgow
 Hull, Ipswich, Leeds

Head Office and Warehouse, Wholesale only

GREAT EASTERN STREET, LONDON, E.C.2
 136 GEORGE STREET, EDINBURGH, 2

Branches
 Liverpool, Manchester
 Newcastle-upon-Tyne
 Nottingham, Oxford, Preston
 Reading, Southampton
 Salford, Telford
 Wakefield

HANDLEBAR STEMS (Steel)—continued

**PRESTO STEEL "TONI MERKINS" HANDLEBAR STEM**

7" long x $\frac{1}{2}$ " dia., 4" curved forward extension complete with expander bolt.
Chromium Plated.

No. 25/H705t/1500 each 22/6

GOOD QUALITY STEEL HANDLEBAR STEMS

Complete with lug bolt and nut, $\frac{1}{2}$ " dia., 2" extension.

Chromium Plated.

Less Expander Bolt.

No. 25/H706c/600 each 9/-

With Expander Bolt.

No. 25/H706d/608 each 10/-

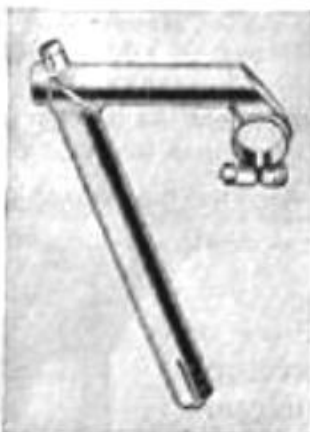
**PRESTO STEEL "TOUR DE FRANCE" HANDLEBAR STEMS**

7" long x $\frac{1}{2}$ " dia.

To suit bends with $\frac{1}{2}$ " ferrules. Fitted with expander bolt. Complete with lug bolt and nut.

Finished in Best Quality Chromium Plating.

2" Forward Extension.
No. 25/H710L/1504 each 23/-

3" Forward Extension.
No. 25/H710m/1508 each 23/6

4" Forward Extension.
No. 25/H710n/1600 each 24/-

**"A. & P." ADJUSTABLE STEEL HANDLEBAR STEM**

Major Taylor Pattern.

6" long x $\frac{1}{2}$ " dia. with $7\frac{1}{2}$ " square extension, complete with adjustable clip, bolts and nuts.

Fitted with Expander Bolt.

Chromium

No. 25/H742b/1707 each 26/4

Without Expander Bolt.

Chromium

No. 25/H742d/1600 each 24/-

**"A. & P." STEEL CURVED HANDLEBAR STEM**

8" long. With lug bolt and nut.

With 3" extension x $\frac{1}{2}$ " stem.

With Flush Joints, No. 8.

Chromium Plated.

No. 25/H736b/963 each 13/11

"A. & P." STEEL CURVED HANDLEBAR STEM

8" long, with lug bolt and nut. Fitted with Expander Bolt. With Flush Joints.

No. 8X.

With 3" extension x $\frac{1}{2}$ " stem.

Chromium.

No. each

25/H738b/1109 17/7

For HANDLEBAR MUFFS refer to page 92

**"PRESTO" STEEL HANDLEBAR STEMS**

Complete with lug bolt and nut, $\frac{1}{2}$ " dia. to suit bends with $\frac{1}{2}$ " ferrules. Fitted with expander bolts.

Finished in Best Quality Chromium Plating.

2" Forward Extension.

No. 25/H708p/1208 each 19/-

3" Forward Extension.

No. 25/H708r/1300 each 19/6

4" Forward Extension.

No. 25/H708s/1304 each 20/-

**"PRESTO" STEEL HANDLEBAR STEMS**

With drop-head forward extension, complete with lug bolt and nut, $\frac{1}{2}$ " dia. to suit bends with $\frac{1}{2}$ " ferrules. Fitted with expander bolt.

Finished in Best Quality Chromium Plating.

1" Forward Extension.

No. 25/H709h/1204 each 20/-

2" Forward Extension.

No. 25/H709l/1304 each 20/-

3" Forward Extension.

No. 25/H709m/1208 each 20/6

4" Forward Extension.

No. 25/H709n/1400 each 21/-

PRICES shown do NOT include PURCHASE TAX which will be charged at current rates where applicable

Branches
Aberdeen, Aston, Belfast
Birmingham, Southampton
Bristol, Cardiff, Chelsea
Croydon, Dublin, Dundee
Exeter, Glasgow
Hull, Ipswich, Leeds

Head Office and Warehouse, Wholesale only:

GREAT EASTERN STREET, LONDON, E.C.2

:126 GEORGE STREET EDINBURGH, 2

Branches
Liverpool, Manchester
Newcastle-upon-Tyne
Nottingham, Oxford, Preston
Reading, Southampton
Sunderland, Swansea
Wolverhampton

HANDLEBAR STEMS (Steel and Alloy)—continued



**STRATA STEEL HANDLEBAR
STEM AND SEAT PILLAR**

Combined for Tandem.

10" long \times $1\frac{1}{4}$ " dia. complete with adjustable clip, bolts and nuts. Forward extension square shaped with domed closed ends. Chromium Plated.

No. 25/H744a/1204 each 18/6



**PRESTO STEEL HANDLEBAR
STEM AND SEAT PILLAR**

Combined for Tandem.

9" long \times $1\frac{1}{4}$ " dia., with 5" forward extension square shaped, complete with adjustable clip.

Finished in Best Quality Chromium Plating.

No. 25/H745a/2308 each 35/6



**PRESTO STEEL "MAJOR TAYLOR"
PATTERN STEM**

With 5" forward extension square shape with domed closed ends. Complete with adjustable clip bolts and nuts and expander.

Finished in Best Quality Chromium Plating.

No. 25/H742p/1804 each 27/6

**"LIEGE-TAYLOR" STEEL
HANDLEBAR STEMS**

With 5" forward extension square shape with closed ends. Complete with adjustable clip, bolts and nuts and expander bolt.

Chromium Plated.

No. 25/H741/1308 each 20/6

(Similar to 25/H742p)



**BURLITE ALLOY HANDLEBAR
STEMS**

7" long with $\frac{1}{2}$ " dia. liner. Complete with expander bolt and leg bolt and nut. Stem is detachable from forward lug.

Polished Alloy.

1" Forward Extension.

No. 25/H750a/700 each 10/6

2" Forward Extension.

No. 25/H750b/708 each 11/6



**"A. & P."
STEEL
HANDLEBAR
STEM AND
SEAT PILLAR**

Combined for Tandem.

12" long, complete with adjustable clip, bolts and nuts. With square end for handlebar clip and round end for saddle clip.

Chromium Plated.

No. 25/H744e/1508 $1\frac{1}{4}$ " dia. .. each 23/2

25/H744b/1601 $1\frac{1}{2}$ " 24/2

25/H744k/1801 $1\frac{3}{4}$ " 24/2

**"ALUMLITE" ALUMINIUM
HANDLEBAR STEMS**

6 $\frac{1}{2}$ " long with $\frac{1}{2}$ " dia. liner. Bend held in position by expander bolt having no forward lug bolt and nut.

1" Forward Extension.

Polished Alloy. No. CA48.

No. 25/H749/511 each 8/11

With 2" ordinary forward extension, complete with lug bolt and nut and expander bolt.

Polished Alloy.

No. 25/H749b/804 No. CA49 each 12/6



**CONSTRICTOR
ADJUSTABLE
HANDLEBAR
STEM**

Adjustable to give different positions from 1 $\frac{1}{4}$ " to 3 $\frac{1}{2}$ ". $\frac{1}{2}$ " stem with extension dia. to suit $\frac{1}{2}$ " ferrules.

Weight 8 oz. without expander bolt.

Polished Alloy.

No. 25/H770k/2604 each 35/-



For HEAD CLIP BOLTS AND NUTS refer to page 92

PRICES shown do NOT include PURCHASE TAX which will be charged at current rates where applicable

Branches
Aberdeen, Aston, Belfast
Birmingham, Bournemouth
Bristol, Cardiff, Cardiff
Croydon, Dublin, Dundee
Exeter, Glasgow
Hull, Liverpool, Leeds

Head Office and Warehouse, Wholesale only:

GREAT EASTERN STREET, LONDON, E.C.2

123 GEORGE STREET EDINBURGH, 2

Branches
Liverpool, Manchester
Newcastle-upon-Tyne
Nottingham, Oxford, Preston
Reading, Southampton
Sheff.-on-Tread
Waterburyton

HEAD LUGS AND HEAD RACES

**BOTTOM HEAD LUGS**

Brampton Pressed Steel.

Size $1\frac{1}{2}'' \times 1\frac{1}{2}'' \times 65''$. (820106.)No. 25/H11000n/5 each -/7 $\frac{1}{2}$ Size $1\frac{1}{2}'' \times 1\frac{1}{2}'' \times 67''$. (820100A.)

For Upright Sets.

No. 25/H11000r/6 each -/9

"Chater Lea"

Size $1\frac{1}{2}'' \times 1\frac{1}{2}'' \times 61\frac{1}{2}''$ No. 1561.

No. 25/H11009d/200 each 2/8

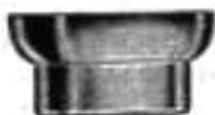
**TOP HEAD LUG BALL RACE SEATINGS (UNPLATED)**

No. 25/H11052d/2 each -/4

**HEAD BALL RACES FOR TOP OR BOTTOM LUGS**

"T.D.C." Best Quality.

Standard size $1\frac{1}{2}''$ diameter.For $\frac{1}{2}''$ balls.

No. 25/H11102a/111 per doz. 3/-

Miniature Cycles.

Size $\frac{3}{8}''$ diameter. For $\frac{1}{2}''$ balls.

No. 25/H11102L/206 per doz. 3/9

"Brampton"

Standard for $\frac{1}{2}''$ balls. (920010.)

No. 25/H11104a/108 per doz. 2/6

To suit Carrier Cycle.

1" clips for $\frac{3}{8}''$ balls. (920011.)

No. 25/H11104m/304 per doz. 8/-

"Chater Lea"

For Head Clip. For $\frac{1}{2}''$ balls No. 1257.No. 25/H11106/101 $\frac{1}{2}$ each 1/525/H11106/1360 $\frac{1}{2}$ per doz. —For $\frac{1}{2}''$ balls. No. 1382.No. 25/H11106a/100 $\frac{1}{2}$ each 1/5

25/H11106a/1204 per doz. —

**GENT'S BOTTOM HEAD LUGS**

Brampton Pressed Steel.

For use with loose seatings, to suit $1\frac{1}{2}''$ head and $1\frac{1}{2}''$ bottom tube. 67".

No. 25/H11015b/7 each -/11

**GENT'S TOP HEAD LUGS**

Brampton Pressed Steel.

For use with loose seatings, to suit $1\frac{1}{2}''$ head and 1" top tube. 68".

No. 25/H11052b/6 each -/9

**HEAD BALL RACES FOR CROWN**

"T.D.C." Best Quality.

Standard size $1\frac{1}{2}''$ diameter, for $\frac{1}{2}''$ balls.

Chromium Plated.

No. 25/H11108b/206 per doz. 3/9

For Miniature Cycles.

Size $\frac{3}{8}''$ diameter. For $\frac{1}{2}''$ balls.

Chromium Plated.

No. 25/H11108L/206 per doz. 3/9

25/H11108m/206 Black 3/9

"Brampton"

Standard for $\frac{1}{2}''$ balls.

Chromium. (925001.)

No. 25/H11109b/204 per doz. 3/6

To suit Carrier Cycle, for $\frac{3}{8}''$ balls.

Chromium Plated. (925005.)

No. 25/H11109n/404 per doz. 6/6

Black (925005.)

No. 25/H11109p/400 per doz. 6/-

"Chater Lea"

For Cycle. For $\frac{1}{2}''$ balls. No. 366.

Chromium Plated.

No. 25/H11110b/105 $\frac{1}{2}$ each 2/-

25/H11110b/1700 per doz. —

**BOTTOM HEAD LUG BALL RACE SEATINGS (UNPLATED)**No. 25/H11015d/2 $\frac{1}{2}$ each -/4**GENT'S TOP HEAD LUGS** $1\frac{1}{2}'' \times 1'' \times 73''$.

For Upright Sets.

No. 25/H11033c/107 each 2/5

"Brampton" Pressed Steel.

Size $1\frac{1}{2}'' \times 1'' \times 68''$. (820000.)

No. 25/H11039n/6 each -/9

Size $1\frac{1}{2}'' \times 1'' \times 70''$. (820011.)

No. 25/H11039p/6 each -/9

"Chater Lea" No. 1560.

Size $1\frac{1}{2}'' \times 1'' \times 73''$.

No. 25/H11040d/110 each 2/6

25/H11040d/2109 per doz. —

**SCREWED HEAD BALL RACES**

"T.D.C." Best Quality.

Size 1" x 24 T.

Shallow Flat Pattern.

Chromium Plated.

No. 25/H11119d/506 per doz. 8/3

Curved Pattern.

1" x 24 T.

No. 25/H11120d/506 per doz. 8/3

For Miniature Cycles.

 $\frac{1}{2}'' \times 24$ T.

No. 25/H1120g/500 per doz. 7/6

"Brampton"

Size $\frac{1}{2}'' \times 30$ T.

Chromium. (925100.)

No. 25/H1121b/411 per doz. 7/4

Size 1" x 24 T., for $\frac{1}{2}''$ balls.

Chromium. (925101.)

No. 25/H1121m/411 per doz. 7/4

Size 1" x 26 T., for $\frac{1}{2}''$ balls.

Chromium Plated. (925130.)

No. 25/H1121r/411 per doz. 7/4

Size 1" x 24 T., for $\frac{3}{8}''$ balls.

Chromium Plated. (925131.)

No. 25/H1122m/600 per doz. 9/-

PRICES shown do NOT include PURCHASE TAX which will be charged at current rates where applicable

Branches
Aberdeen, Arrol, Belfast
Birmingham, Bournemouth
Bristol, Cardiff, Carlisle
Croydon, Dublin, Dundee
Exeter, Glasgow
Hull, Newcastle, Leeds

Head Office and Workshops, Wholesale only:

GREAT EASTERN STREET, LONDON, E.C.2

136 GEORGE STREET EDINBURGH, 2

Branches
Liverpool, Manchester
Newcastle-upon-Tyne
Nottingham, Oxford, Preston
Reading, Southampton
Sheffield, Tynes
Wolverhampton

HEAD RACES—continued

HEAD LOCK NUTS AND HEAD STEMS



ROUND PATTERN SOLID HEAD LOCK NUTS

"T.D.C." Best Quality.

Chromium Plated. 1" x 24 T.

No. 25/H1146d/409 .. per doz. 7/2

Brampton

3/4" x 30 T. (915000.)

Chromium Plated.

No. 25/H1143b/404 .. per doz. 6/6

Chater Lea No. 443

Chromium Plated.

Size 1" x 26 T.

No. 25/H1145b/1071 each 2/3



"CYCLO" PATENT DUPLEX HEXAGON LOCKING HEAD NUT

With tapered split collar to grip stem. Duralium material, polished, screwed 1" x 24 T.

No. 25/H1149/205 each 3/9



BRAMPTON HEXAGON HEAD LOCK NUTS

Chromium Plated.

Size 3/4" x 30 T. (915001.)

No. 25/H1146f/611 .. per doz. 10/6

Size 1" x 26 T. (915021.)

No. 25/H1146l/611 .. per doz. 10/6

Size 1 1/4" x 26 T. (915600.)

No. 25/H1146s/800 .. per doz. 12/-



HEAD PACKING WASHER

Can be used in place of lamp brackets.

Chromium Plated.

No. 25/H1150h/204 1" dia. per doz. 3/6



"T.D.C." HEXAGON SOLID HEAD LOCK NUTS

Chromium Plated.

Standard Size 1" x 24 T.

No. 25/H1147d/506 .. per doz. 8/3

Juvenile size 3/4" x 24 T.

No. 25/H1148g/700 .. per doz. 10/6



BRAMPTON CONTINENTAL TYPE ENGLISH PATTERN CUP AND CONE HEAD FITTINGS

Comprising: Lock nut 1" x 24 T. Washer with tongue. Screwed ball race for 3/4" ball 1" x 24 T. Top ball race. Bottom ball race. Crown ball race.

Chromium Plated.

No. 25/H1135w/204 .. per set 3/6



BUTTED HEAD STEMS

Head Clip Pattern.

Screwed and slotted (without lock nut).

"A. & P." Best Quality.

1" dia. x 24 T., 16 x 13 G.

No. 25/H1200n/109 1/2 Heads 7", Length 10" .. each 2/8

For Carrier Cycles.

1" dia. x 24 T.

No. 25/H1201/201 Length 10" each 3/2

Reynolds "A" Best Quality.

3/4" dia. x 30 T.

No. 25/H1206f/111 1/2 Heads 7", length 10" .. each 2/11

1" dia. x 24 T.

No. 25/H1206x/200 1/2 Heads 8", length 11" .. each 3/-

Reynolds "H.M." Quality.

Tandem 16 G. with 9 G. Butt.

1 1/4" dia. x 26 T.

No. 25/H1207c/401 Length 10 1/2" each 6/2



BUTTED HEAD STEMS

For Expander Head (without Lock Nut).

"A & P." Best Quality.

1" dia. x 24 T., 16 x 13 G.

Length

No. 25/H1208l/103 8" each 1/11

25/H1208m/104 9" 2/-

25/H1209n/105 10" 2/2

Reynolds "A" Quality.

1" dia. x 24 T., 16 x 13 G.

Length

No. 25/H1213l/105 8" each 2/2

25/H1213m/106 9" 2/1

25/H1213n/107 10" 2/5

Reynolds "H.M." Quality.

1" dia. x 24 T., 16 x 13 G.

No. 25/H1214t/205 Length 10" each 3/7

PRICES shown do NOT include PURCHASE TAX which will be charged at current rates where applicable

Branches:
Aberdeen, Accrington, Belfast,
Birmingham, Bolton,
Bradford, Cardiff, Carlisle,
Crawley, Dundee, Glasgow,
Huddersfield, Leicester,
Liverpool, Manchester,
Newcastle, Nottingham,
Preston, Reading, Southampton,
Sheffield, Stockport,
Tottenham, Wakefield,
Wolverhampton.

Head Office and Warehouse, Wholesale only:

GREAT EASTERN STREET, LONDON, E.C.2

125 GEORGE STREET EDINBURGH, 2

Branches:
Liverpool, Manchester,
Newcastle, Nottingham,
Preston, Reading, Southampton,
Sheffield, Stockport,
Tottenham, Wakefield,
Wolverhampton.

HEAD TUBE DIES, HOLDERS, etc.



CYCLO HEAD TUBE DIE, HOLDER AND GUIDE

Made with taper cutting edges for screwing head tubes.
Holder complete with Die (No. 116/DA).

No. 25/H1246/2103	Size $\frac{1}{2}$ " x 24 T.	each
(Complete with special split bush to fit over $\frac{1}{2}$ " tubes)				
25/H1246a/2000	Size $\frac{1}{2}$ " x 30 T.	each
25/H1246d/2000	" 1" x 24 T.	"
25/H1246f/2000	" 1" x 26 T.	"

Tandem Size.				
No. 25/H1246k/2500	Size $1\frac{1}{2}$ " x 26 T.	each

Extra Dies (Standard No. 116D).

No. 25/H1246n/906	Size $\frac{1}{2}$ " x 24 T.	each
25/H1246p/906	" $\frac{1}{2}$ " x 30 T.	"
25/H1246s/906	" 1" x 24 T.	"
25/H1246t/906	" 1" x 26 T.	"

Tandem Size (109/D).

No. 25/H1246w/1406	Size $1\frac{1}{2}$ " x 26 T.	each
--------------------	-------------------------------	----	----	------

Split Adjustable Dies.

No. 25/H1246na/1406	Size $\frac{1}{2}$ " x 24 T.	each
25/H1246pa/1406	" $\frac{1}{2}$ " x 30 T.	"
25/H1246sa/1406	" 1" x 24 T.	"
25/H1246ta/1406	" 1" x 26 T.	"

These dies have a small tolerance each side of the actual size to allow the thread to be cut in increasing depths and so prevent binding.

Special split bush to fit $\frac{1}{2}$ " tube for use with H1246 Head Tube Die and Holder.

No. 25/H1246x/103	..	Bush only	..	each
-------------------	----	-----------	----	------



CYCLO REDUCING CUTTERS

To reduce 1" tubes to $\frac{1}{2}$ " to fit

No. 25/H1246a. (No. 127.)

No. 25/H1246e/906	each
-------------------	----	----	------

CYCLO HEAD LUG REAMER WITH REVOLVING GUIDE

For truing the cup seatings of Ball Heads after the frames are built up. Suitable for any length of head.

For "B.S.A." Size Lugs and Races.

Complete. No. 119.

No. 25/H1255h/1706	each
--------------------	----	----	------

Extra Cutters (No. 119C).

No. 25/H1255k/1206	each
--------------------	----	----	------

For SPOKE DIES AND CUTTERS
See Page 220.

BRADBURY HEAD TUBE DIE AND HOLDER WITH GUIDE

For screwing head tubes. Stock sizes $\frac{1}{2}$ " x 30 T. (B.S.A. size).
Sizes 1" x 24 and 26 T.

Complete with holder,

No. 25/H1247a/4209	each
--------------------	----	----	----	------

Extra dies. Outside diameter size $1\frac{1}{2}$ " dia. x $\frac{1}{2}$ ".

No. 25/H1247c/2511	each
--------------------	----	----	----	------

No. 25/H1247d/504	..	Extra Guides	..	each
-------------------	----	--------------	----	------

No. 25/H1247e/2409	..	Reducing cutters to reduce 1" tube to $\frac{1}{2}$ ".	..	each
--------------------	----	--	----	------



BRADBURY BALL HEAD REAMER

For truing the cup seatings of Ball Heads after the frames are built up. Made to suit any length of head.

For "B.S.A." Size Lugs and Races.

No. 25/H1255a/5006	..	Reamer complete	..	each
--------------------	----	-----------------	----	------

No. 25/H1255e/2206	..	Extra cutters	..	each
--------------------	----	---------------	----	------

"VAR" HEAD LUG AND BOTTOM BRACKET REAMER COMBINED No. 8

With revolving guide. When used on the head tube lug it cleans off all surplus metal from inside the tube and dresses the edges of the tube ready to receive the ball races.



When used on the bottom bracket the reamer No. 3 is removed, and the tool then used to dress off the edges of the bracket shell. Continental Make.

No. 25/H1255p/17000	each
---------------------	----	----	----	------

"VAR" HEAD RACE SEATING PRESS TOOL No. 6

A neat and efficient tool, which, in one operation presses the top and bottom ball race seating into the head tube of a frame, leaving them firmly seated home and parallel.

Continental Make.

No. 25/H1255t/7500	each
--------------------	----	----	----	------

THE "SUN" PATENT TANDEM HEEL BRAKE LEVER

With strong clip for fitting to $1\frac{1}{2}$ " dia. main tubes, to be used in conjunction with rod-operated rear Tandem internal expanding brake hubs. For direct drive only.

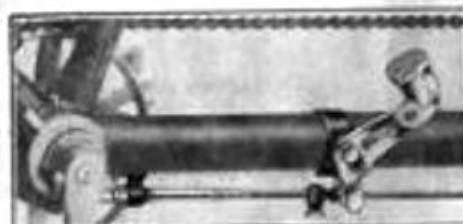

Chromium Plated.

No. 25/H1266c/1600	each 24/-
--------------------	----	----	----	-----------

This Brake Lever can be fitted very quickly and easily on any tandem machine already having a rod brake similar to the illustration shown, and having a main tube $1\frac{1}{2}$ " dia. The rider has two means of working his rear brake, either by hand or foot, both entirely independent of each other.

PRICES shown do NOT include PURCHASE TAX which will be charged at current rates where applicable

Branches
Aberdeen, Ayles, Belfast
Birmingham, Blackburn
Bristol, Cardiff, Carlisle
Croydon, Dublin, Dundee
Exeter, Glasgow, London
Newcastle, Leeds

Head Office and Workshops. Wholesale only:

GREAT EASTERN STREET, LONDON, E.C.2

128 GEORGE STREET EDINBURGH, 2

Branches
Liverpool, Manchester
Newcastle-upon-Tyne
Nottingham, Oxford, Preston
Reading, Southampton
Sheffield, Telford
Wolverhampton

HUBS



"B.H." "SIVADA" HUBS
(Less cogs and lock rings.)

1 1/2" Chain Line drilled rear 40 holes, front 32 holes.

Chromium Plated.

Without Gear Case Clearance.

No. 25/H1400c/400	Front. Standard	each	5/7
25/H1400f/402	Front. With cone lock nuts	5/9
25/H1400h/502	Rear. Single Cog	7/3
25/H1400k/504	Rear. Double Cog	7/6

With Gear Case Clearance.

No. 25/H1401h/502	Rear. Single Cog	each	7/3
-------------------	------------------	-------	------	-----



"B.H." TRANSPORT CARRIER CYCLE HUBS

For Tradesmen's Cycles, specially strong, with 1" spindles and best chrome steel cones

All black.

1 1/2" Chain Line, with Gear Case Clearance.

No. 25/H1410c/404	Front Hub, 32 holes	each	6/2
25/H1410h/505	Rear .. 40	7/7

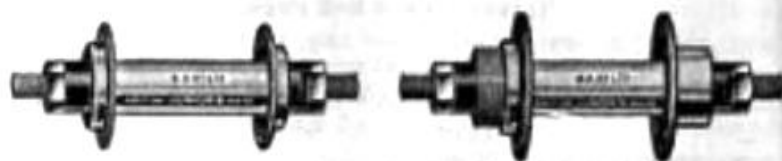

"B.H." JUNIOR HUBS

1 1/2" chain line. Screwed 1" dia. x 20 threads to suit free wheel.

Ball Bearing. Chromium Plated. 20/20 holes.

No. 25/H1415c/204	Front	each	3/3
25/H1415d/305	Rear	4/10



"B.H." TANDEM FRONT HUB

32 holes, width of flanges 2 1/2", barrel 1 1/2", width over cone locking nuts, 3 1/2", length of spindle, 5 1/2".

No. 25/H1422h/604	Chromium Plated	each	7/6
-------------------	-----------------	-------	------	-----



"B.H." TANDEM REAR HUB

(Less cogs and lock rings.)

With solid spindle, reversible, double screwed for one cog and lock ring on each side, fitted with cone locking nuts, 40 holes, 1 1/2" Chain Line, width of flanges, 2 1/2", barrel 1 1/2", width over cone locking nuts 4 1/2", length of spindle 6 1/2".

No. 25/H1422b/607 1/2	Chromium Plated	each	8/7
-----------------------	-----------------	-------	------	-----

For a comprehensive range of racing hubs (B.H. "Airlite" and "Solite"), manufactured by the British Hub Co., Ltd., refer to pages 100-101

PRICES shown do NOT include PURCHASE TAX which will be charged at current rates where applicable

Branches:
Aberdeen, Ayles, Bolton
Birmingham, Bournemouth
Bristol, Cardiff, Cardiff
Croydon, Dublin, Dundee
Leicester, Glasgow
Plymouth, Leeds

Head Office and Warehouse, Wholesale only:

GREAT EASTERN STREET, LONDON, E.C. 2
124 GEORGE STREET EDINBURGH, 2

Branches:
Liverpool, Manchester
Newcastle-on-Tyne
Nottingham, Oxford, Preston
Reading, Southampton
Sheffield, Truro
Wolverhampton

HUBS—continued

Fitted with
Tecalmit type
nipples with
round hollow
end spindles.

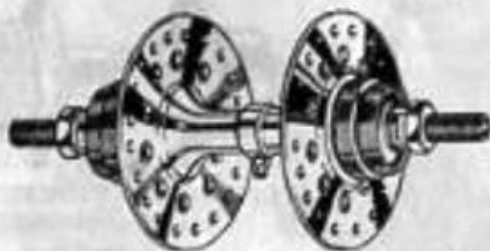

Complete with
cone lock nuts.
Polished alloy
finish.



BLUMFIELD DURALITE LIGHTWEIGHT RACING HUBS

Small Flange Rear Hubs.

Drilled 40 holes, dia. of flanges 2".

1 1/2" Chain Line. Length of spindle 5 1/2".

Double screwed to take cog and lock rings.

Model DDS.

No. 25/H1454a/2000 each 27/6

Single screwed to take cog and lock ring.

Model DSS.

No. 25/H1454d/2000 each 27/6

Single screwed for Derailleur gear.

Model DSS/D.

No. 25/H1454e/2000 each 27/6

Double screwed to take cog and lock ring
and for Derailleur gear, 4 1/2" over cones.

Model DDS/D.

No. 25/H1454f/2000 each 27/6

Double screwed to take cog and lock ring,
and Derailleur gear with free wheels, using
narrow chains 4 1/2" over cones. Model DDS/F.

No. 25/H1454g/2000 each 27/6

Small Flange Front Hub to suit above.

32 holes, width on lock nuts 3 1/2", length of
spindle 4 1/2". Diameter of flanges 1 1/2", centre
of flanges 2 1/2". Model DF.

No. 25/H1454p/1406 each 20/-

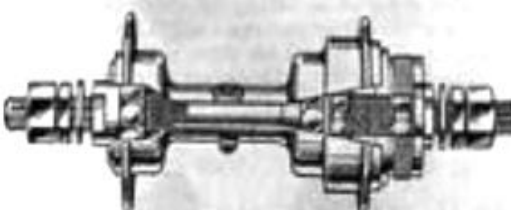

BAYLISS WILEY FREE WHEEL HUB

For use with Derailleur gears, screwed one
side. Complete with 3 cogs, sizes 14-21 T.
inclusive. 1 1/2" Chain Line. Chromium Plated.

No. 25/H1461k/3200 each 46/3

Large Flange Rear Hubs.

Hubs drilled with taper sized flanges. Drilled
40 holes, diameter of flanges 3", centre of
flanges 1 1/2". Length of spindle 5 1/2". 1 1/2"
Chain Line, width over lock nuts 4 1/2".

Double screwed to take cog and lock ring.

Model LDS.

No. 25/H1455a/2506 each 37/-

Single screwed to take cog and lock ring.

Model LSS.

No. 25/H1455d/2506 each 37/-

Single screwed for Derailleur gear.

Model LSS/D.

No. 25/H1455e/2506 each 37/-

Double screwed to take cog and lock ring and
for Derailleur gear. Model LDS/D.

No. 25/H1455f/2606 each 37/-

Double screwed to take cog and lock ring and
for Derailleur gear with free wheels using
narrow chain. Model LDS/F.

No. 25/H1455g/2606 each 37/-

Large Flange Front Hub to suit above.

32 holes, width over lock nuts 3 1/2", length of
spindle 4 1/2". Diameter of flanges 2 1/2", centre
of flanges 2 1/2". Model LF.

No. 25/H1455p/1906 each 28/-

"DURA" LIGHTWEIGHT
RACING HUBS

(Continental Make.)

Small flanges of polished duralumin
and narrow barrel with hardened steel
spindle.

Front drilled 32 holes,

Width over cone lock nuts 3 1/2".

Rear drilled 40 holes.

Double screwed for cog and lock ring
and Derailleur gear. Width over cone
lock nuts 4 1/2".

No. 25/H1456d/1606 .. per pair 24/9

"EXCELTOO" DURAL RACING
HUBS

(Continental Make.)

Double screwed for cog and lock ring, and
for Derailleur gear, drilled 32/40 holes.

Boxed in pairs.

No. 25/H1456p/2000 No. 350 pair 30/-

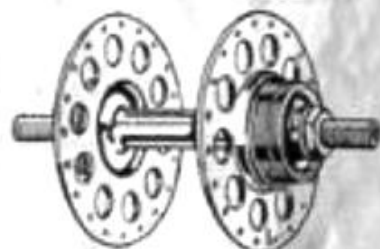
BAYLISS WILEY "CONTINENTAL"
RACING HUBS

Front only No. 19.

With 2 1/2" dia. light alloy large flanges, with
8 holes, 2 1/2" wide between flanges, 1/8" dia.
chromium plated barrel, 5" long spindles,
fitted with cone lock nuts and washers,
drilled 32 holes.

No. 25/H1461a/1708 each 24/9

Rear No. 20.

With 3 1/2" dia. light alloy flanges, with holes
drilled in flanges for lightness. Chromium
plated steel barrel with 6" spindle with hollow
ends and flat ended. Width over lock nuts
4 1/2", width between flanges 2 1/2". Fitted with
cone lock nuts and washers. Drilled 40 holes.

Double sided screwed for cog and lock rings.

No. 25/H1461c/2008 each 28/11

Rear No. 21

Double sided, screwed for cog and lock rings
and Derailleur gear (Spindle 6 1/2" long).

No. 25/H1461e/2008 each 28/11

Rear No. 22

Single sided, screwed for Derailleur gear only
(Spindle 6 1/2" long).

No. 25H/1461g/2008 each 28/11

PRICES shown do NOT include PURCHASE TAX which will be charged at current rates where applicable

Branches
Aberdeen, Arona, Belfast
Birmingham, Bournemouth
Bristol, Cardiff, Carlisle
Croydon, Dublin, Dundee
Exeter, Glasgow
Hull, Ipswich, Leeds

Head Office and Warehouse, Whitehall only:

GREAT EASTERN STREET, LONDON, E.C.2

134 GEORGE STREET EDINBURGH, 2

Branches
Liverpool, Manchester
Newcastle-upon-Tyne
Nottingham, Oxford, Preston
Reading, Southampton
Sheffield, Trent
Wolverhampton

HUBS—continued



HARDEN LIGHTWEIGHT RACING HUBS

Heat treated, rustproof Aluminium Alloy, one piece, Hub shell Precision machined and polished. Fitted with standard Tecalemit Grease nipple, with Hoffman Ball Bearing Races in place of usual cup and cone. Spindle made from high tensile (65 ton) special alloy steel.

Small Flange.

Diameter of flanges 2". Spoke holes lightly countersunk.

Front Hubs. Drilled 32 holes.

No. 25/H1502e/2204 No. 1036 each 33/6

Rear Hubs. Drilled 40 holes.

Single sided, screwed for cog and lock ring.

No. 25/H1502k/2404 No. 1038 each 36/6

Single sided, screwed for Derailleur gear.

No. 25/H1502m/2500 No. 1040 each 37/6

Double sided, screwed for cog and lock ring

both sides.

No. 25/H1502n/2508 No. 1042 each 38/6

Double sided, screwed for cog and lock ring

one side and Derailleur gear other side.

No. 25/H1502p/2608 No. 1044 each 40/6



Large Flange.

Diameter of flange 3 1/2" drilled with 1/2" dia. holes to further lighten the hubs. Spoke holes lightly countersunk both sides.

Front Hubs. Drilled 32 holes

No. 25/H1501e/2104 No. 1026 each 32/6

Rear Hubs. Drilled 40 holes

Single sided, screwed for cog and lock ring

No. 25/H1501k/2600 No. 1028 each 39/6

Single sided, screwed for Derailleur gear.

No. 25/H1501m/2600 No. 1030 each 39/6

Double sided, screwed for cog and lock ring

both sides.

No. 25/H1501n/2800 No. 1032 each 42/6

Double sided, screwed for Derailleur gear one

side, for cog and lock ring other side.

No. 25/H1501p/2800 No. 1034 each 42/6

HARDEN FREE WHEEL HUBS

Can be obtained to special order.
Please state size of sprocket required.

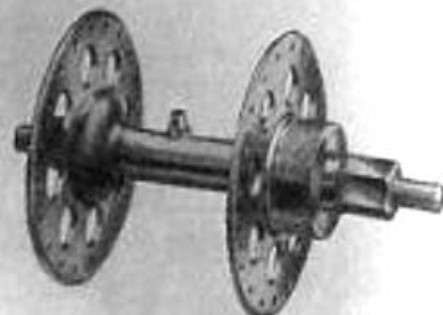

HARDEN "FLYWATE" LIGHTWEIGHT RACING HUBS

Similar to "Harden" Lightweight Racing Hubs, but with cups and cones for adjustment as required. Available in Large Flange or

Polished Alloy.

Front. No. 2026

No. 25/H1503e/1908 each 29/6

Rear, double sided, screwed for cog and lock ring. No. 2032

No. 25/H1503n/2004 each 39/6

Rear double sided, screwed for Derailleur gear. No. 2034

No. 25/H1503p/2004 each 39/6

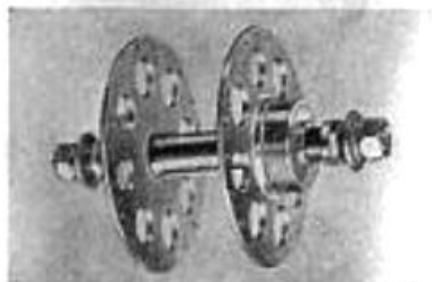

CHATER LEA LIGHTWEIGHT RACING HUBS

Hub shells are made of aluminium in one piece, machined and highly polished, lock nuts and cones made of carbon chrome steel fitting 1/2" steel balls. Spindles have axial lightening holes at both ends. Lubrication by Tecalemit oil gun nipple fitted in one end of spindle, fitted with oil seals, preventing ingress of water and dust.

Front Hub. No. 1627.

Drilled 32 holes, diameter of flanges 1 1/2", width over cone lock nuts 3 1/2".

Weight with Track Nuts 6 1/2 oz.

No. 25/H1505e/1810 each 26/6

Rear Hub. No. 1608.

Drilled 40 holes, 1 1/2" chain line, diameter of flanges 2 1/2", width over cone lock nuts 4 1/2".

Weight with Track Nuts (less cog and lock ring) 8 1/2 oz.

No. 25/H1506p/2303 each 32/6

CHATER LEA LIGHTWEIGHT LARGE FLANGE RACING HUBS

Hub shells are made of aluminium in one piece, machined highly polished, cups and cones made of carbon chrome steel take 1/2" steel balls. Spindles have axial lightening holes at both ends, with oil gun nipple fitted at one end. Flanges have lightening holes machined in them and spoke holes lightly countersunk to 15 G. rolled thread spoke.

Hubs have oil seals of special oil resisting rubber fitted to spindle and prevent ingress of water and dust.

Front Hub. No. 1660.

Drilled 32 holes, diameter of flanges 3 1/2", width over cone lock nuts 3 1/2". Weight with Track Nuts 8 1/2 oz.

No. 25/H1506g/3111 each 41/6

Rear Hub. No. 1651.

Drilled 40 holes, diameter of flanges 3 1/2", width over cone lock nuts 4 1/2". Flanges of rear hub are offset to accommodate a multi-sprocket free wheel and the mean chain line is 1 1/2".

Weight with Track Nuts (less cogs and lock rings) 10 1/2 oz.

No. 25/H1506s/3410 each 48/6

PRICES shown do NOT include PURCHASE TAX which will be charged at current rates where applicable

Branches:
Aberdeen, Aston, Belfast,
Birmingham, Bournemouth,
Bradford, Cardiff, Carlisle,
Croydon, Dublin, Dundee,
Exeter, Glasgow,
Hull, Inverness, Leeds

Head Office and Warehouses, Wholesale only

GREAT EASTERN STREET, LONDON, E.C.2

125 GEORGE STREET EDINBURGH, 2

Branches:
Liverpool, Manchester,
Newcastle upon Tyne,
Nottingham, Oxford, Preston,
Reading, Southampton,
Tottenham, Wolverhampton

HUBS—continued

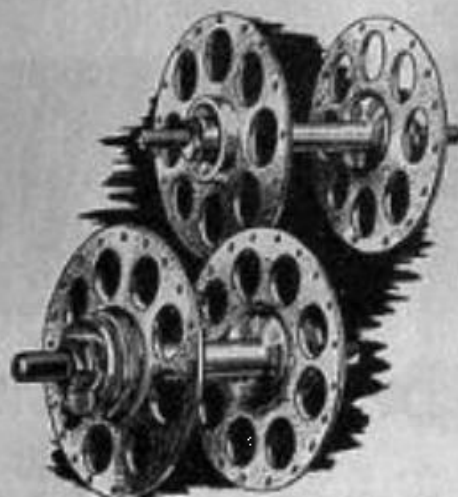

POWELL LIGHTWEIGHT RACING HUBS

Polished bidurium spoked flanges, hub shell and ball races of high tensile steel. Heat treated and accurately ground. Hollowed spindles with Tecaletit liners, fitted with carbon steel cones, washers and lock nuts.

Small Flange Model.

Front, diameter of flanges 2", width over cone lock nuts 3½", length of spindle 5½".

No. 25/H1536a/1100 each 18/-

Rear, double screwed for cog and lock ring on both sides, diameter of flanges 2", width over cone lock nuts 4½", length of spindle 6½".

No. 25/H1536d/1600 each 23/-

Rear, double screwed for cog and lock ring and Derailleur gear, diameter of flanges 2", width over cone lock nuts 5½", length of spindle 6½".

No. 25/H1536f/1900 each 26/-

Large Flange Model.

(Flanges drilled with ½" holes for lightness.)

Front, diameter of flanges 3½", width over cone lock nuts 3½", length of spindle 5½".

No. 25/H1536t/2006 each 32/-

Rear, double screwed for cog and lock ring on both sides, diameter of flanges 3½", width over cone lock nuts 4½", length of spindle 6½".

No. 25/H1536p/2500 each 37/-

Rear, double screwed for cog and lock ring one side and Derailleur on other side, diameter of flanges 3½", width over cone lock nuts 5½", length of spindle 6½".

No. 25/H1536s/2800 each 40/-

RADNALL'S PATENT ALL-STEEL OIL BATH HUBS

1¼" Chain Line with Gear Case Clearance.

Screwed for Free Wheel.

Rear.

Chromium Plated.

No. 25/H11838b/403 each 6/6

Front.

Chromium Plated.

No. 25/H11838c/307 each 4/7

PRICES shown do NOT include PURCHASE TAX which will be charged at current rates where applicable

Branches
Aberdeen, Aachen, Belfast
Birmingham, Bournemouth
Bristol, Cardiff, Cardiff
Croydon, Dublin, Dundee
Exeter, Glasgow
Hull, Inverness, Leeds

Head Office and Warehouse, Whitechapel, E.C. 1

GREAT EASTERN STREET, LONDON, E.C. 2

124 GEORGE STREET EDINBURGH, 2

Branches
Liverpool, Manchester
Newcastle-upon-Tyne
Nottingham, Oxford, Preston
Reading, Southampton
Sheffield, Tyneside
Wolverhampton

HUB COGS

Please refer
to
Pages 113-114

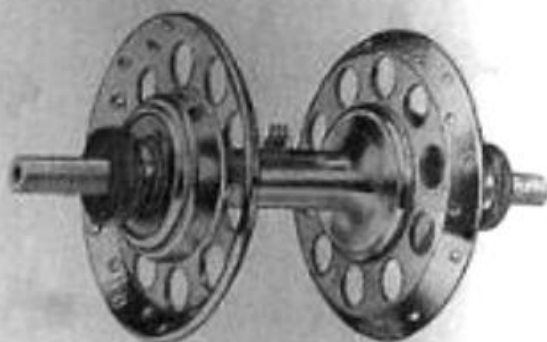

SHELLWIN LIGHTWEIGHT RACING HUBS

Hub shell and flanges of special light alloy polished, with nickel chrome molybdenum steel spindles, grooved and hollow ends. Hardened steel cones, washers and lock nuts.

Small Flange Model.

Front, diameter of flange 1½", width over cone lock nuts 4", length of spindle 5½".

No. 25/H1537a/1204 each 18/-

Rear, double screwed for cog and lock ring both sides, flat ends spindles. Diameter of flange 2".

No. 25/H1537d/1700 each 25/-

Rear, double screwed for cog and lock ring and Derailleur gear. Length of spindle 5½", width over cone lock nuts 4½". Diameter of flange 2".

No. 25/H1537f/1607 each 24/-

Large Flange Model.

With angular rim edge, holes drilled in flanges for lightness. Diameter of flanges 3".

Front, width over cone lock nut 3½", length of spindle 5".

No. 25/H1537l/1608 each 25/-

Rear, double screwed for cog and lock ring on both sides. Flat ended spindle.

No. 25/H1537p/2007 each 30/11

Rear, double screwed for cog and lock ring on one side and Derailleur gear on other side. Width over cone lock nuts 5", length of spindle 6½".

No. 25/H1537s/2101 each 31/-

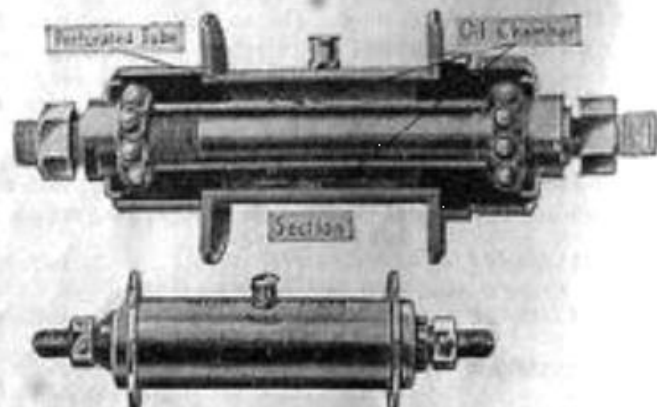

HUBS—continued (Expanding Brake and Coaster)

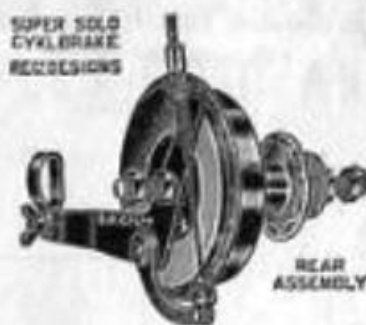
SUPER TANDEM
CYKLBRAKE
REGS. DESIGNSFRONT
ASSEMBLYSUPER TANDEM
CYKLBRAKE
REGS. DESIGNREAR
ASSEMBLYSUPER SOLO
CYKLBRAKE
REGS. DESIGNSREAR
ASSEMBLYSUPER SOLO
CYKLBRAKE
REGS. DESIGNSFRONT
ASSEMBLY

"B.H." SUPER SPECIAL TANDEM CYKLBRAKES

Complete with Handlebar Lever with Band clip, and Waterproof Cable Control for front brake, and cable-cum-rod for rear brake.

Chromium Plated Finish

Front, drilled 32 holes, 4½" brake drums.

For Tandem.

No. 25/H1551b/3200 each 44/11

Rear, 4½" brake drums.

Screwed to take "Cyclo" or similar Deraillleur gear.

No. 25/H1551w/3503 each 49/4

"B.H." SUPER SOLO CYKLBRAKE

The Cyklbrake internal expanding Brake Hub, can be used with either free wheel or fixed cog, complete with Handlebar Lever with Band clip and Waterproof Cable Control.

Chromium Plated Finish.

Rear, drilled 40 holes 1½" chain line. Screwed 1½" x 24 T.

3½" brake drums.

No. 25/H1552b/2400 each 33/7

Front, drilled 32 holes. 3½" brake drums.

No. 25/H1552r/2009 each 29/2

STURMEY-ARGHER INTERNAL
EXPANDING BRAKE HUBS

Complete with Handlebar Brake Lever Waterproof Cable Control, with detachable Front Fork and Rear Stay Clips.

Rear, Model BRG.

For Gent's Solo Cycle. 1½" C.L. 40 holes.

No. 25/H1560b/1900 Chromium Plated 26/6

Front, Model BFG.

For Solo Cycle. 32 holes.

No. 25/H1560r/1806 Chromium Plated 25/6

Rod Control

Hubs can be supplied with Rod Control bottom parts, minus brake tubed top parts (in lieu of Cable Control), suitable for Solo machines with Handlebar Roller Levers and Rods, at same prices.

Spoke Lengths.

For 26" x 1½" rims 10½" and 11½" long.
 .. 26" x 1½" .. 10½" .. 11½" ..
 .. 26" x 1½" .. 10½" .. 11" ..
 .. 28" x 1½" .. 11½" .. 12" ..

These lengths are for three cross lacing on fronts and four cross lacing on rears.

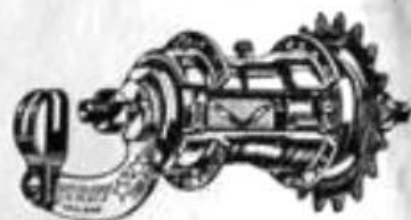

PERRY "2 STAR" COASTER HUB

Complete with 48" Sprocket.

Drilled 40 holes. Chain Lines 1½" or 1¼".

Chromium Plated.

No. 25/H1571b/1500 each 20/-

SUN PATENT TANDEM HEEL BRAKE LEVERS

To be used in conjunction with rod operated Tandem rear internal expanding brake hubs.

Please see page 95.

PRICES shown do NOT include PURCHASE TAX which will be charged at current rates where applicable

Branches:
 Aberdeen, Ayles, Belfast
 Birmingham, Blackburn
 Bristol, Cardiff, Carlisle
 Coventry, D. Ince, Dundee
 Exeter, Glasgow
 Hull, Ipswich, Leeds

Head Office and Warehouse, Wholesale only

GREAT EASTERN STREET, LONDON, E.C.2

124 GEORGE STREET EDINBURGH 1

Branches:
 Liverpool, Manchester
 Newcastle upon Tyne
 Nottingham, Oxford, Preston
 Reading, Southampton
 Stock-on-Trent
 Wolverhampton

HUBS—continued (Coaster and Variable)

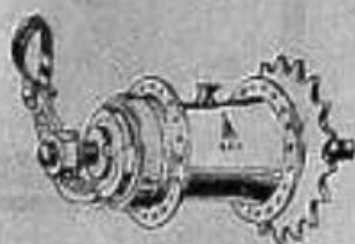

"EADIE" COASTER HUB
(1950 pattern).

Complete with $18 \times \frac{1}{4}$ " sprocket.
Drilled 40 holes, $1\frac{1}{2}$ " chain line
with round end spindles.

Chromium Plated.

No. 25/H1570e/2603

each 21/-

"B.S.A." THREE-
SPEED HUB

Complete with sprocket.
Top tube control, and
waterproof covered cable.
Drilled 40 holes.

Chromium Plated.

No. 25/H1576t/2700

each 37/6

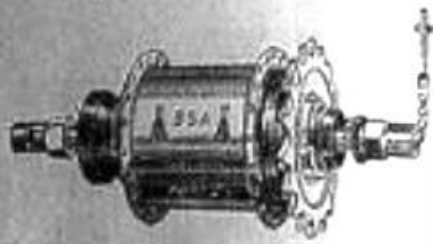

STURMEY-ARCHER THREE-SPEED
MEDIUM RATIO GEAR HUBS

Model AM.

Complete with quick release fittings and
wing nuts. Drilled 40 holes.

Chromium Plated.

For Solo Machines.

With Spined Sprockets.

Top tube control.

No. 25/H1581h/2300 each 45/6

With Handlebar Trigger Control.

No. 25/H1581bt/3300 each 45/6



STURMEY-ARCHER
TRIGGER CONTROL
AND PARTS

See page 132.



STURMEY-ARCHER
THREE-SPEED CLOSE RATIO
FIXED GEAR HUB

Model ABC.

Made up with light alloy hub shell, and
supplied with handlebar flick trigger control.
Complete with quick release fittings, wing
nuts and spined sprocket.

Chromium Plated.

1st (Low Gear) 25% decrease from normal.

2nd (Middle) 10%

3rd (High Gear) Direct drive.

No. 25/H1581m/4009 each 56



STURMEY-ARCHER THREE-SPEED
ULTRA CLOSE RATIO
GEAR HUB

Model AC.

Made up with light alloy hub shell and
supplied with handlebar flick trigger control.
Complete with quick release fittings, wing
nuts and spined sprocket.

Chromium Plated.

Ratios give 6-66% increase and 7-7% de-
crease from normal.

No. 25/H1582t/3006 each 54/-

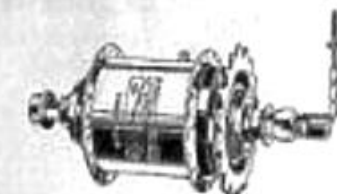

STURMEY-ARCHER
THREE-SPEED GEAR HUB
Model AW.

Complete with screwed sprocket, and cable
control.

Chromium Plated.

Ratios give 33 1/3% increase and 25% decrease
from normal.

With Top Tube Control.

No. 25/H1585b/2700 each 37/6

With Handlebar Flick Trigger Control.

No. 25/H1585r/2700 each 37/6



STURMEY-ARCHER
FOUR-SPEED WIDE RATIO HUB
GEAR

Model FW.

Complete with handlebar flick trigger control
and screwed sprocket.

Chromium Plated.

1st (Low Gear) 33 1/3% decrease from
normal.

2nd (Intermediate) 21% decrease from
normal.

3rd (Normal) Direct drive.

4th (High) 26% increase from
normal.

No. 25/H1584b/3700 each 43/6

For "STURMEY-ARCHER"
DYNOHUB and THREE-SPEED
HUB COMBINED
See LAMP SECTION

PRICES shown do NOT include PURCHASE TAX which will be charged at current rates where applicable

Branches
Aberdeen, Arona, Belfast
Birmingham, Bournemouth
Bristol, Cardiff, Carlisle,
Croydon, Dublin, Dundee,
Exeter, Glasgow,
Hull, Ipswich, Leeds.

Head Office and Showrooms, Wholesale order

GREAT EASTERN STREET, LONDON, E.C. 2

125 GEORGE STREET EDINBURGH, 2.

Branches
Liverpool, Manchester
Newcastle-on-Tyne
Nottingham, Oxford, Preston
Reading, Southampton
Sheffield, Tyneside
Wolverhampton

HUBS—continued (Variable, and Derailleur Gears)



STURMELEY-ARCHER FOUR-SPEED CLOSE RATIO GEAR HUB

Model FG.

Made up with light alloy hub shell and supplied with handlebar flick trigger control, wing nuts, splined sprocket and quick release fittings.

Chromium Plated.

1st (Low Gear)	25% decrease from normal.
2nd (Intermediate)	10% decrease from normal.
3rd (Normal)	Direct drive.
4th (High)	9-1% increase over normal.
No. 25/H1584b/3906 each 54/6



STURMELEY-ARCHER FOUR-SPEED MEDIUM RATIO GEAR HUB

Model FM.

Made up with light alloy hub shell and supplied with handlebar flick trigger control, wing nuts, splined sprocket and quick release fittings.

Chromium Plated.

1st (Low Gear)	33 1/2% decrease from normal.
2nd (Intermediate)	14-3% decrease from normal.
3rd (Normal)	Direct drive.
4th (High)	12-5% increase over normal.
No. 25/H1586r/3700 each 51/3



STURMELEY-ARCHER THREE-SPEED WIDE RATIO HUB

With Internal Expanding Brake.

Model ABC.

For Gent's Cycle.

Complete with handlebar brake lever, waterproof covered cable control and handlebar flick trigger control. Drilled 40 holes.

Chromium Plated.

No. 25/H1587b/3700 each 51/-
Gear Ratio 33 1/2% increase and 25% decrease from normal.



CYCLO DERAILLEUR ROLLER CHAIN SPEED GEARS

Complete with Top Tube Control, Double Cable and Free Wheel.

Double Cog Jockey Tension Models.

Single Cog and Pulley.

Note: Gears fitted with single cog and pulley can be obtained at extra charge.

-/110 extra 2/9

Dural System.

Note: Gears fitted with Cyclo Dural System can be obtained at extra charge.

-/706 extra 10/-

Above extras can be obtained separately.
Please see page 126.

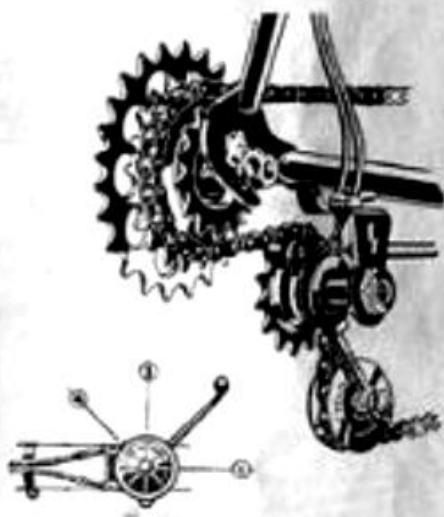

Two Speed.

For Cycles.

No. 25/H1590b/2304 each 35/-

For Tandem.

No. 25/H1590e/2500 each 37/6

Three Speed.

For Cycles.

No. 25/H1590b/2608 each 40/-

For Tandem.

No. 25/H1590m/3000 each 45/-

Four Speed.

For Cycles.

No. 25/H1600b/3000 each 45/-

For Tandem.

No. 25/H1600m/3304 each 50/-

A Complete and Comprehensive range of replacement parts for all Sturmeley-Archer gears can be found on pages 129-138.

PRICES shown do NOT include PURCHASE TAX which will be charged at current rates where applicable

Branches
Aberdeen, Arona, Belfast
Birmingham, Bournemouth
Bristol, Cardiff, Carlisle
Croydon, Exeter, Dundee
Luton, Glasgow
Hull, Ipswich, Leeds

Head Office and Workrooms, Wholesale only

GREAT EASTERN STREET, LONDON, E.C.2

126 GEORGE STREET EDINBURGH, 2

Branches
Liverpool, Manchester
Newcastle-upon-Tyne
Nottingham, Oxford, Preston
Reading, Southampton
Sheffield, Tynes
Wolverhampton

HUBS—continued (Derailleur Gears)



CYCLO "ROSALITE" LIGHTWEIGHT HUBS

Manufactured from one piece shell made from drop forged stamping of highest quality tensile strength 35/42 tons per square inch. Will take both "Cyclo" and "Boss" type multiple free wheels, highly polished finish, complete with Rosa track nuts.

Front Hub.

Flanges $1\frac{1}{2}$ " dia. Width over lock cone nuts $3\frac{1}{2}$ ".

No. 25/H1597d/804 No. 501 each 12/6

Rear Hub.

Screwed double sided for single speed free wheel with other side screwed for fixed sprocket and lock ring. Diameter of flanges $2\frac{1}{2}$ ". Width over cone lock nuts $4\frac{1}{2}$ ".

No. 25/H1597g/1108 No. 503 each 17/6

Screwed one side for free wheel. Diameter of flanges $2\frac{1}{2}$ ".

Width over lock nuts $4\frac{1}{2}$ ".

No. 25/H1597l/1100 No. 502 each 16/6

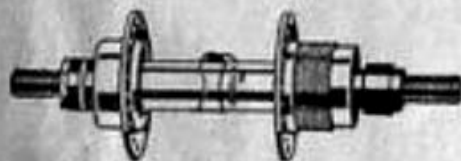

CYCLO DERAILLEUR REAR CYCLE HUB

Single screwed for use with triple free wheels and chain speed gears. Drilled 40 holes. $4\frac{1}{2}$ " wide over packing washers.

Chromium Plated.

No. 25/H1597b/808 No. 804/B each 10/-

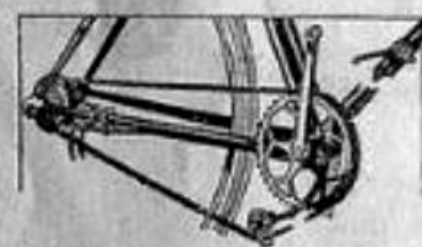

CYCLO "ACE"
THREE-SPEED
CLOSE RATIO
DERAILLEUR
CHAIN SPEED GEAR

Complete with aluminium disc, spoke protector, triple free wheel, chain stay clip and chain guide, down tube jockey arm,

seat tube chain guide clip, twin waterproof covered cable and quadrant lever and clip.

For Solo Model only.

Low gear: 19, 20 and 21 T. (fixed)

Middle gear: 17 and 18 T. (loose)

Top gear: 15 and 16 T. (loose)

No. 25/H1603/2704 (less hub) each 35/-

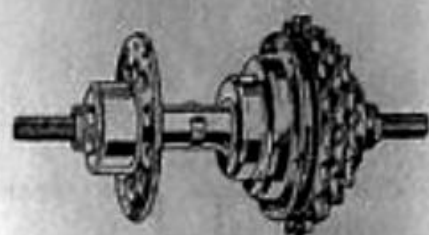

CYCLO FREE WHEEL HUB UNIT

Suitable for all types of Derailleur gears.

Hub complete with free wheel, sizes of cogs available 12 T. to 26 T. interchangeable on all gears.

Chromium Plated.

Three-speed unit No. 804.

No. 25/H1597t/3304 each 5/0

Four-speed unit No. 804a.

No. 25/H1597w/3402 each 5/1

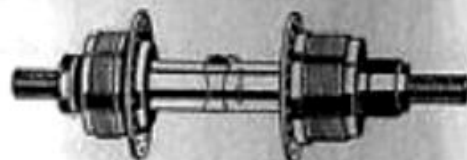

CYCLO DERAILLEUR REAR TANDEM HUB

Double Screwed for single and triple free wheels. $5\frac{1}{2}$ " wide over packing washers. Drilled 40 holes.

Chromium Plated.

No. 25/H1597h/804 each 12/-

CYCLO "OPPY"
THREE-SPEED
DERAILLEUR GEAR

Chromium-plated parts with down tube control with silver finish waterproof covered cables. Complete with triple free wheel.

Sprocket size $\frac{1}{2}$ " x $\frac{1}{4}$ " for Solo machine.

Sizes as follows:

Low Gear, 19, 20, 21, 22, 23, 24 T.

Middle Gear, 17, 18 T.

Top Gear, 13, 14, 15 and 16 T.

No. 25/H1616b/2608 Clip Fitting. each 4/0

No. 25/H1616c/2608 Braze-on Fitting. each 4/0



PRICES shown do NOT include PURCHASE TAX which will be charged at current rates where applicable

Branches:
Aberdeen, Aston, Belfast
Birmingham, Bournemouth
Bristol, Cardiff, Cardiff
Coventry, Dublin, Dundee
Exeter, Glasgow
Hull, Ipswich, Leeds

Head Office and Warehouse, Wholesale only.

GREAT EASTERN STREET, LONDON, E.C.2

128 GEORGE STREET EDINBURGH, 2

Branches:
Liverpool, Manchester
Newcastle-upon-Tyne
Nottingham, Oxford, Preston
Reading, Southampton
Sheffield, Trent
Wolverhampton

HUBS—continued (Derailleur Gears)

THREE-SPEED

Complete with Cyclo Standard Free Wheel.
(Pointed formed teeth.)

Sprocket sizes.

Top	13 to 15 T.
Middle	17 to 18 T.
Low	18 to 20 T.

No. 25/H1601d/3000 each 45/-

Complete with Cyclo "Benelux" Free Wheel.
(Square formed teeth.)

Sprocket sizes.

Top	14 to 15 T.
Middle	16 to 17 T.
Low	18 to 20 T.

No. 25/H1601e/3204 each 50/-

Complete. Less Free Wheel.

No. 25/H1601dl/2000 each 30/-

FIVE-SPEED ($\frac{1}{2} \times \frac{1}{8}$ "

Complete with Cyclo "Benelux" Free Wheel.
(Square formed teeth.)

Sprocket sizes.

Top	13 to 14 T.
2nd	15 to 16 T.
3rd	16 to 19 T.
4th and 5th	18 to 23 T.

No. 25/H1601p/4608 each 70/-

Complete. Less Free Wheel.

In $\frac{1}{2} \times \frac{1}{8}$ " only.

No. 25/H1601pt/2000 each 30/-

CYCLO "BENELUX"
PROFESSIONAL TYPE ROLLER
CHAIN SPEED GEARS

(Standard Type.)

Complete with "Benelux" Handlebar Control, and waterproof covered cable. Made in light alloy and with steel parts where necessary. Chromium Plated and Polished Alloy finish.



All the above gears can be supplied with Standard "Cyclo" Top Tube control at the same prices as above.

For "CYCLO" FREE WHEELS
Refer to pages 75-76.

FOUR-SPEED ($\frac{1}{2} \times \frac{1}{8}$ "

Complete with Cyclo Standard Free Wheel.
(Pointed formed teeth.)

Sprocket sizes.

Top	13 to 15 T.
2nd	17 to 18 T.
3rd	18 to 21 T.
4th	19 to 23 T.

No. 25/H1601h/3204 each 50/-

Complete with Cyclo "Benelux" Free Wheel.
(Square formed teeth.)

Sprocket sizes.

Top	14 to 15 T.
2nd	16 to 17 T.
3rd and 4th	18 to 23 T.

No. 25/H1601k/3804 each 57/6

Complete. Less Free Wheel.

Suitable for $\frac{1}{2} \times \frac{1}{8}$ " only.

No. 25/H1601hl/2000 each 30/-

FOUR-SPEED ($\frac{1}{2} \times \frac{1}{8}$ "

Complete with Cyclo "Benelux" Free Wheel.
(Square formed teeth.)

Sprocket sizes.

Top	14 to 15 T.
2nd	16 to 17 T.
3rd and 4th	18 to 23 T.

No. 25/H1601l/4108 each 62/6

Complete. Less Free Wheel.

Suitable for $\frac{1}{2} \times \frac{1}{8}$ " only.

No. 25/H1601ll/2000 each 30/-

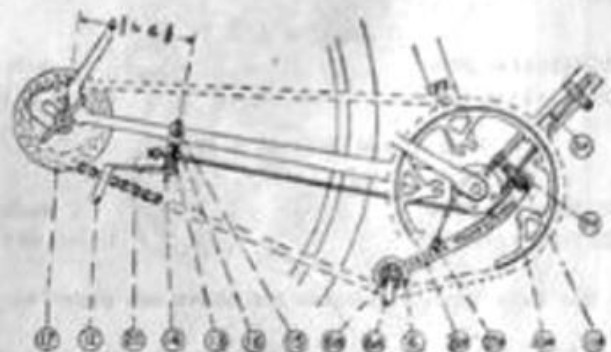

Continental Make.

Professional Single Roller Type.

Three-speed complete, less Free Wheel.

No. 25/H1604a/2308 each 34/-

Three-speed complete with Triple Free Wheel.

Plain pattern (cog sizes 16-18-20 T.).

No. 25/H1604m/3208 each 47/6

Three-speed complete with Triple Free Wheel.

Doss pattern (cog sizes 14-16-18 T.).

No. 25/H1605m/3708 each 55/-

CYCLO "OLYMPIC"
DERAILLEUR GEAR

Complete with Top Tube Control and waterproof covered cable in silver finish.

Chromium Plated.

Spindle fitting bracket clip. Gear complete with Standard Triple Free Wheel.

No. 25/H1613/2608 each 40/-

Gear complete with Standard Four-speed Free Wheel.

No. 25/H1613c/3000 each 45/-

CONSTRUCTOR SUPER "CHAMPION OSGEAR"
DERAILLEUR THREE-SPEED GEARS

Complete with aluminium disc spoke protector, chain fork guide anchor, triple free wheel, chain stay clip and chain guide, down tube jockey arm, seat tube chain guide clip, waterproof covered cable and cable adjuster and quadrant lever and clip.

PRICES shown do NOT include PURCHASE TAX which will be charged at current rates where applicable

Branches
Aberdeen, Ayles, Belfast
Birmingham, Bournemouth
Bristol, Cardiff, Cardiff
Croydon, Dublin, Dundee
Exeter, Glasgow
Hull, Ipswich, Leeds

Head Office and Warehouse, Wholesale only

GREAT EASTERN STREET, LONDON, E.C.2

134 GEORGE STREET EDINBURGH, 1

Branches
Liverpool, Manchester
Newcastle-upon-Tyne
Nottingham, Oxford, Preston
Reading, Southampton
Sunderland, Tyneside
Wolverhampton

HUBS—continued (Derailleur Gears)

CONSTRUCTOR "SUPER
MONDIAL" DOUBLE
ROLLER DERAILLEUR
GEARS

Continental Make.

The latest addition to the Osgear
range of Derailleur gears. Polished
alloy finish, with steel parts where
necessary. Weight 11½ oz.

Three-speed complete,
less Free Wheel.

No. 25/H11605a/1904 each 29/-

Four-speed complete,
less Free Wheel.

No. 25/H11605g.2000 each 30/-

CONSTRUCTOR "CONLOY OSGEAR" SINGLE ROLLER
TYPE DERAILLEUR GEAR

Continental Make.

Made of Conloy material in highly polished finish. Weight 12 oz.

System complete, less Free Wheel.

No. 25/H1606a/2108 each 32½

System complete with Triple Free Wheel, plain pattern (cog sizes
16-18-20 T.).

No. 25/H1606b/3008 each 46/-

System complete with Triple Free Wheel, boss pattern (cog sizes
14-16-18 T.).

No. 25/H1606c/3508 each 53½

Refer to page 76 for CONSTRUCTOR FREE WHEELS

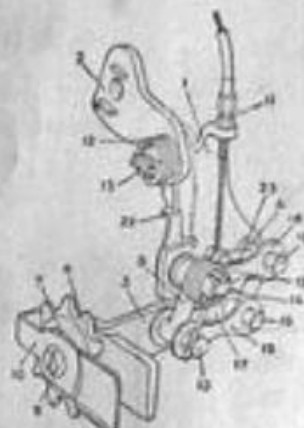

SIMPLEX "TOUR DE FRANCE" DERAILLEUR GEAR

Continental Make.

Complete with control cable and lever. For Solo machines.

Three Speed (less Free Wheel).

For $\frac{1}{2} \times \frac{1}{2}$ ".

No. 25/H1611st.2000 each 30/-
25/H1611st.1800 In lots of 1 doz

Four Speed (less Free Wheel).

For $\frac{1}{2} \times \frac{1}{2}$ ".

No. 25/H1611dt.2000 each 30/-
25/H1611dt.1800 In lots of 1 doz

For $\frac{1}{2} \times \frac{1}{2}$ ".

No. 25/H1611et.2000 each 30/-
25/H1611et.1800 In lots of 1 doz

Five Speed (less Free Wheel).

For $\frac{1}{2} \times \frac{1}{2}$ ".

No. 25/H1611gt.2000 each 30/-
25/H1611gt.1800 In lots of 1 doz

For Free Wheels suitable for above see page 76.

Note:—The additional discounts given for the dozen rate of the
above Simplex gears do not apply to free wheels purchased
complete same.

For SPARES for "CYCLO" and "SIMPLEX"
DERAILLEUR GEARS
Refer to pages 121-128.

PRICES shown do NOT include PURCHASE TAX which will be charged at current rates where applicable

Branches:
Aberdeen, Ayr, Belfast
Birmingham, Bournemouth
Bristol, Cardiff, Carlisle
Croydon, Dublin, Dundee
Lithburn, Glasgow
Raid Greenock, Leeds

Head Office and Warehouse, Wholesale only:

GREAT EASTERN STREET, LONDON, E.C.2

136 GEORGE STREET EDINBURGH. 2

Branches:
Liverpool, Manchester
Newcastle-upon-Tyne
Nottingham, Oxford, Preston
Reading, Southampton
Sheffield, Tranter
Wolverhampton

HUBS—continued (Derailleur Gears)

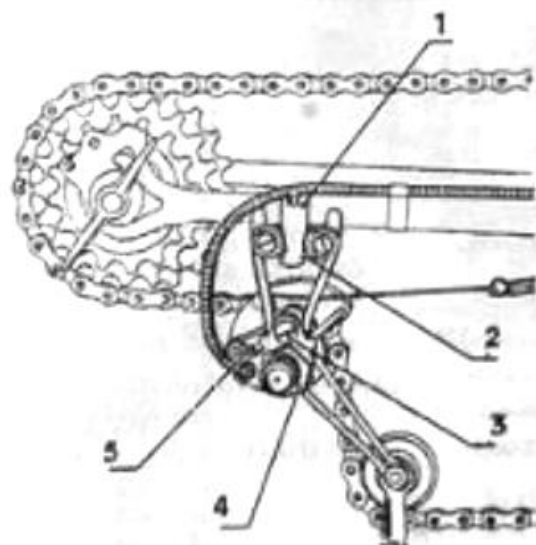

HURET "TOURISTE" DERAILLEUR GEAR
(less Free Wheels)

Double roller pattern and is made entirely of spring steel wire, complete with top tube lever control, less Free Wheel. Gear suitable for both three and four-speed $\frac{1}{2} \times \frac{1}{4}$ " Free Wheels. Chromium Plated.

No. 25/H1630bL/1303 each 20/-

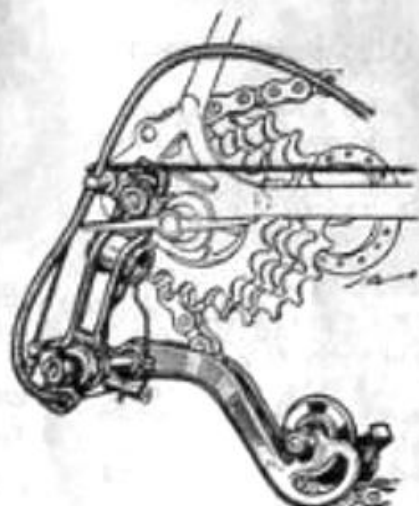

HURET "COMPETITION SPECIAL" DERAILLEUR GEAR
(less Free Wheels)

Single roller type similar to "Competition Standard" model, suitable for 3-, 4- or 5-speed Free Wheels $\frac{1}{2}$ " or $\frac{3}{8}$ " size by adjustment. Specially adapted for racing by the addition of a chain tension lever incorporated into the change lever control. This gear is ideal with Front Derailleur and Double Chain Wheel.

Chromium Plated.
No. 25/H1630LL/1406 each 22/-

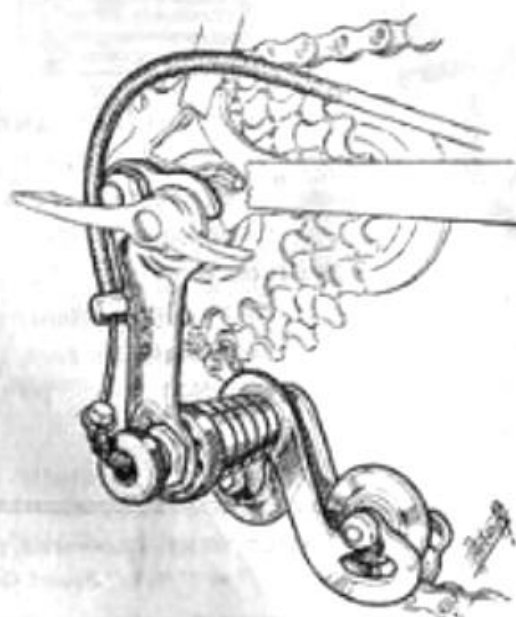

HURET "TOUR DE FRANCE" DERAILLEUR GEARS
(less Free Wheels)

Double roller type complete with top tube lever control, less Free Wheel.

Chromium Plated.

No. 25/H1630pt/1608	..	$\frac{1}{2} \times \frac{1}{4}$ "	3-speed	..	each 25/-
25/H1630rL/1608	4-speed	..	25/-
No. 25/H1630sl/1608	..	$\frac{1}{2} \times \frac{3}{8}$ "	4-speed	..	each 25/-
25/H1630tt/1608	5-speed	..	25/-

HURET PREFERENCE FREEWHEELS
Please see page 76.



HURET "COMPETITION STANDARD" DERAILLEUR GEAR
(less Free Wheels)

Single roller type with top tube lever control. This gear can be made to operate on 3-, 4- or 5-speeds by a slight screw adjustment. By using spacing washers each side of tension roller the cages are suitable for both $\frac{1}{2}$ " or $\frac{3}{8}$ " dia.

Chromium Plated.
No. 25/H1630fL/1303 each 20/-

PRICES shown do NOT include PURCHASE TAX which will be charged at current rates where applicable

Branches:
Aberdeen, Aston, Belfast
Birmingham, Bournemouth
Bristol, Cardiff, Cardiff
Croydon, Dublin, Dundee,
Exeter, Glasgow, Glasgow
Hull, Ipswich, Leeds

Head Office and Warehouse, Wholesale only:

GREAT EASTERN STREET, LONDON, E.C.2

126, GEORGE STREET EDINBURGH, 2

Branches:
Liverpool, Manchester
Newcastle-upon-Tyne
Nottingham, Oxford, Preston
Reading, Southampton
Sheffield, Stockport
Wolverhampton

HUB GEAR CABLES, ETC. HUB CLEANERS



"VINDEC" HUB BRAKE CABLES

Complete with waterproof (woven) covered outer cable and non-fray inner wire and nipples. Each cable packed in individual cartons printed "Vindec" showing list numbers and for which hub brake it is suitable.

Black Finish.

For "S.A." Old Pattern
(illus. above)

No. 25/H1642u/108	Front	each 2/6
25/H1642b/201	Rear	3/2
25/H1642c/204	Rear Ladies	3/6



For "S.A." New Pattern

No. 25/H1643u/107	Front	each 2/4
25/H1643b/201	Rear	3/2

"VINDEC" INNER AND OUTER CABLE

For Derailleur Gears.
For Simplex, Beaulax, etc.
42" long. Size 6.

Inner Wire. With one soldered nipple.

No. 25/H1646k/4	each -/6
25/H1646k/308	doz. —

Outer Casing. Waterproof.
Silver Finish.

No. 25/H1646l/7	each -/10
25/H1646l/699	doz. —

Outer Casing. 50 ft. Coils.

No. 25/H1646r/606	Coil 8/3
-------------------	----	----	----------

CABLE WIRE. Celluloid Covered.
For "B.S.A." or "S.A." Gears.
25 foot coils.

Black Finish.

No. 25/H1649l/200	each 3/9
-------------------	----	----	----------

Silver Finish.

No. 25/H1649a/200	each 3/-
-------------------	----	----	----------



"VINDEC" HUB GEAR CONTROL WIRES

For trigger or flick controls.
Celluloid covered.

Suitable for 3- and 4-speed gears.

To suit "Hercules" 3-Speed Gears.

(illus. above)

Silver Finish.

No. 25/H1646h/101	each 1/9
-------------------	----	----	----------



To suit "S.A." Old Pattern 3 and 4 speed

Black Finish

No. 25/H1646s/101	each 1/9
-------------------	----	----	----------



To suit "S.A." New Pattern

Black Finish

No. 25/H1646x/102	each 1/9
-------------------	----	----	----------



CONTROL WIRES FOR TOP TUBE CONTROLS

"Vindec" celluloid covered.

Black. To suit "S.A." With fixed end nipples

No. 25/H1648b/71	36" Long	..	each -/11
25/H1648b/202		..	per doz. —
25/H1648c/7	32" Long	..	each -/10
25/H1648c/609		..	per doz. —

"Dover" Exonite Covered.

To suit "B.S.A." With fixed end plate.

No. 25/H1647d/6	38" Long	..	each -/9
-----------------	----------	----	----------

To suit "S.A." With fixed end nipple.

No. 25/H1648d/6	38" Long	..	each -/9
-----------------	----------	----	----------

For Sports Machines.

With fixed end nipples. 33" Long.

No. 25/H1647h/6	"B.S.A."	..	each -/9
25/H1648h/6	"S.A."	..	-/9



"ROSA" DERAILLEUR TWO GROOVE SPRING STEEL STAY CLIPS FOR 1/2" TO 1" ROUND

Also suitable for Hub Brake Cables.

Blue finish, to secure cables to back top stay for neat appearance.

No. 25/H1644/100	per doz 1/6
------------------	----	----	-------------



"VINDEC" HUB CLEANERS

Best Quality Leather.

Standard size. For front or rear hubs.

1 dozen pairs on a card.

No. 25/H1645a/406	per card 6/-
-------------------	----	----	--------------

For 3-speed Gear Hubs.

On Cards of 1 doz. pairs.

No. 25/H1645c/803	per card 12/-
-------------------	----	----	---------------

CABLE WIRE Uncovered, for "B.S.A." or "S.A." Speed Gears.

1/2" x 7 Strand Tinned with soldered ends.
25 foot coils.

No. 25/H1649c/91	each 1
------------------	----	----	--------

50 foot coils.

No. 25/H1649d/106	each 2
-------------------	----	----	--------

100 foot coils.

No. 25/H1649f/210	each 4
-------------------	----	----	--------

PRICES shown do NOT include PURCHASE TAX which will be charged at current rates where applicable

Branches:
Aberdeen, Aston, Belfast
Birmingham, Bournemouth
Bristol, Cardiff, Carlisle
Croydon, Dublin, Dundee
Exeter, Glasgow
Hull, Ipswich, Leeds

Head Office and Warehouses, Wholesale only.

GREAT EASTERN STREET, LONDON, E.C.2

126 GEORGE STREET, EDINBURGH, 2

Branches:
Liverpool, Manchester
Newcastle-upon-Tyne
Nottingham, Oxford, Preston
Reading, Southampton
Sheffield, Tyneside
Wolverhampton

HUB COGS



"T.D.C." HUB COGS

Not Hardened.

 $\frac{1}{2}$ " pitch. Screwed. 24 thread. $\frac{1}{8}$ " bore, $\frac{1}{4}$ " wide.

No. 25/H1670k/202	14 T.	each	3/3
25/H1670k/208	16 T.	"	4/-
25/H1670k/303	18 T.	"	4/11
25/H1670k/311	20 T.	"	6/-

 $\frac{1}{4}$ " bore, $\frac{1}{2}$ " wide.

No. 25/H1670m/404	22 T.	each	6/6
25/H1670p/411	24 T.	"	7/6

 $\frac{1}{8}$ " bore, $\frac{3}{8}$ " wide.

No. 25/H1671k/202	14 T.	each	3/3
25/H1671k/208	16 T.	"	4/-
25/H1671k/303	18 T.	"	4/11
25/H1671k/311	20 T.	"	6/-

 $\frac{1}{4}$ " bore, $\frac{1}{2}$ " wide.

No. 25/H1671m/404	22 T.	each	6/6
25/H1671p/411	24 T.	"	7/6

 $\frac{1}{4}$ " bore, $\frac{1}{4}$ " or $\frac{3}{8}$ " wide.

No. 25/H1672/506	26 T.	"	8/3
25/H1672/600	28 T.	"	9/-
25/H1672/606	30 T.	"	9/9
25/H1672/700	32 T.	"	10/6

We can also obtain other sizes from 14 T. rising by one tooth to 60 teeth in $\frac{1}{2}$ " pitch \times $\frac{1}{4}$ " or $\frac{3}{8}$ " to special order.

"T.D.C." CYCLE HUB COGS

Screwed standard bore

 $\frac{1}{4}$ " \times 24 thread. $\frac{1}{2}$ " pitch \times $\frac{1}{4}$ " wide.

13, 14, 15 or 16 T.

No. 25/H1660g/11 $\frac{1}{2}$	"	each	1/5
	17, 18, 19 or 20 T.		

No. 25/H1660k/101	"	each	1/8
-------------------	---	------	-----

1" pitch \times $\frac{1}{2}$ " wide.

6 and 7 T.

No. 25/H1667g/	per doz.		
----------------	----------	--	--

8 and 9 T.

No. 25/H1667h/	per doz.		
----------------	----------	--	--

"T.D.C."

LIGHTWEIGHT HUB COGS

Cadmium Plated. Offset Plain.

 $\frac{1}{2}$ " \times $\frac{1}{4}$ ".

No. 25/H1700e/	16 T.	each	
25/H1700f/	17 T.	"	
25/H1700g/	18 T.	"	
25/H1700h/	19 T.	"	
25/H1700k/	20 T.	"	
25/H1700l/	22 T.	"	

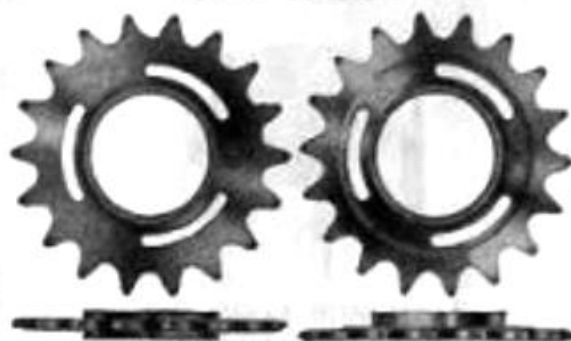

"B.W." LIGHTWEIGHT HUB COGS

 $\frac{1}{2}$ " pitch \times $\frac{1}{4}$ " wide. Screwed. $\frac{1}{4}$ " \times 24 thread.

Offset Plain.

14 and 15 T.

No. 25/H1685f/806	"	per doz.	12/9
-------------------	---	----------	------

16 T.

No. 25/H1685g/809	"	per doz.	13/3
-------------------	---	----------	------

Offset Cut-out.

No. 25/H1685k/809	17 T.	per doz.	13/3
-------------------	-------	----------	------

No. 25/H1685l/906	18 T.	"	14/3
-------------------	-------	---	------

No. 25/H1685n/1000	20 T.	"	15/-
--------------------	-------	---	------

For "B.W." Continental Hubs

Central plain, 14 T.

No. 25/H1684b/203	"	each	3/2
-------------------	---	------	-----

Central cut-out.

15 and 16 T.

No. 25/H1684c/207	"	each	3/8
-------------------	---	------	-----

STURMEY-ARCHER HUB COGS

Screw-on Pattern.

To suit Models AW, AB and FW Hubs.

 $\frac{1}{2}$ " \times $\frac{1}{4}$ ". 16, 17, 18, 19 and 20 T.

No. 25/H1707n/101 $\frac{1}{2}$	"	each	1/8
---------------------------------	---	------	-----

Splined or Slotted Pattern to push on.

To suit Models AM, ASC, FM, FC and AC.

 $\frac{1}{2}$ " \times $\frac{1}{4}$ ". 14, 15, 16, 17, 18, 19 and 20 T.

No. 25/H1707r/101 $\frac{1}{2}$	"	each	1/8
---------------------------------	---	------	-----



VILLIERS

LIGHTWEIGHT HUB COGS

 $\frac{1}{2}$ " pitch \times $\frac{1}{4}$ " wide.

Central.

Sizes: 12, 13, 14, 15, 16 T.

No. 25/H1710k/1300	"	per doz.	17/-
--------------------	---	----------	------

Sizes: 17, 18, 19, 20 T.

No. 25/H1710k/1400	"	per doz.	19/-
--------------------	---	----------	------

Offset.

Sizes: 12, 13, 14, 15, 16 T.

No. 25/H1711k/1300	"	per doz.	17/-
--------------------	---	----------	------

Sizes: 17, 18, 19, 21, 22 T.

No. 25/H1711k/1400	"	per doz.	19/-
--------------------	---	----------	------

HUB COGS FOR "B.W." UNIT
COMBINED FREE WHEEL HUBS

Teeth specially machined to work with Derailleur Gear.

Available in sizes 14, 15, 16, 17, 18, 19 and 20 T. $\frac{1}{2}$ " \times $\frac{1}{4}$ ".

With Boss.

No. 25/H1687a/1500	"	per doz.	21/-
--------------------	---	----------	------

Without Boss.

Specially made to adapt Unit Hub for use as 4-speed gear.

Available in 17 T. only.

No. 25/H1687p/1500	"	per doz.	21/-
--------------------	---	----------	------

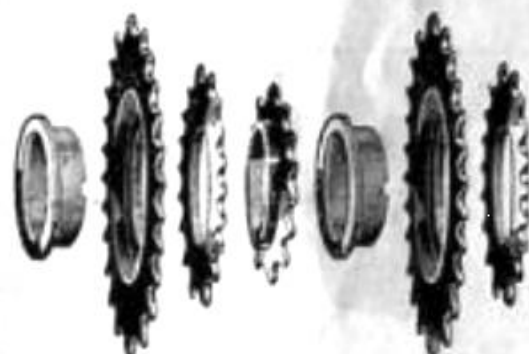
CYCLO CONVERSION SETS
OF SPROCKETS

With screw-on sleeve adaptor, screwed $\frac{1}{4}$ " dia. \times 24 thread. Specially suitable for use with existing 3-speed hubs, to convert to 6- or more speed gear.

Double cog set with screwed sleeve.

Top gear sprocket sizes 13, 14, 15, 16, 17 and 18 T.

Bottom gear sprocket sizes 17, 18, 19, 20, 21 and 22 T.

No. 25/H1703k/608	"	per set	10/0
-------------------	---	---------	------

Triple cog set with screwed sleeve to convert to 9-speed gear.

Top gear sprocket sizes 13, 14, 15 to 18 T.

Middle gear sprocket sizes 18, 19 or 20 T.

Low gear sprocket sizes 24 or 26 T.

No. 25/H1703p/1000	"	per set	15/-
--------------------	---	---------	------

PRICES shown do NOT include PURCHASE TAX which will be charged at current rates where applicable

Branches:
Aberdeen, Aston, Belfast
Birmingham, Bournemouth
Bristol, Cardiff, Carlisle
Croydon, Dublin, Dundee
Exeter, Glasgow, Gillingham
Hull, Inverness, Leeds

Head Office and Warehouse, Wholesale only

GREAT EASTERN STREET, LONDON, E.C. 2

124 GEORGE STREET EDINBURGH, 2

Branches:
Liverpool, Manchester
Newcastle-upon-Tyne
Nottingham, Oxford, Preston
Reading, Southampton
Sheffield, Telford

HUB CUPS, ETC. HUB SPINDLES



FRONT HUB CUPS (Hardened)

"Cyclo" Best Quality.

No. 25/H1764a/504 .. per doz. 8/-

"Cyclo" Second Quality.

No. 25/H1764c/204 .. per doz. 3/6

"B.S.A." Genuine.

No. 25/H1764g/503 .. per doz. 8/-

"Phillips" No. H4-9

Suitable for Nos. 36 Hubs.

No. 25/H1764n/111 .. per doz. 2/11

"Phillips" No. H4-2

Suitable for Nos. 37, 168, 169, 170, 176, 178, 451, 452 and 453 hubs.

No. 25/H1764p/110 .. per doz. 2/9

HUB CUP DISCS OR CUP END PLATES

"B.S.A." STEEL.

No. 25/H1776a/108 Front per doz. 2/-

25/H1776b/108 Rear .. 2/-



REAR HUB CUPS (Hardened)

"Cyclo" Best Quality.

No. 25/H1766a/600 .. per doz. 9/-

"Cyclo" Second Quality.

No. 25/H1766c/300 .. per doz. 4/6

"B.S.A." Genuine.

No. 25/H1766g/507 .. per doz. 7/-

"Phillips" No. H4-11

Suitable for Nos. 167 and 450 hubs.

No. 25/H1766n/110 .. per doz. 2/9

"Phillips" No. H4-1

Suitable for Nos. 39 and 42 hubs.

No. 25/H1766p/202 .. per doz. 3/3

FOR COMPLETE RANGE OF
STEEL BALLS
REFER TO PAGE 1.



CYCLO HUB DIE

("B.S.A." Size, 1 1/4" x 24 thread).

Complete with holder.

No. 25/H1819g/2000 each —

"HARDEN" ALLOY SPACING
WASHERS OR COLLARS

1 1/2" bore x 1/4" thick. (No. 1019)

No. 25/H1747a/8 1/2" Wide each —9

25/H1747b/8 1/2" —9

"HARDEN" ALUMINIUM
SPOKE GUARDS OR DISCS

1 1/2" bore x 1/4" thick x 3 1/2" outside dia.

(No. 1018).

No. 25/H1747g/9 each 1/2



HUB SPINDLES, SHOULDERED

Complete with cones and nuts.

Standard Pattern.

"Bayliss Wiley" Genuine. Plated.

No. 25/H1874a/104 Front each 1/10 1/2

25/H1874d/105 1/2 Rear 2/0 1/2

25/H1874g/106 Front with cone lock nuts .. 2/1

25/H1874l/108 Rear with cone lock nuts .. 2/4



HUB SPINDLES, NOT SHOULDERED

Complete with cones and nuts.

"B.B.L." Best Quality. Plated.

Standard Pattern.

No. 25/H1878a/10 Front 4 1/2" long x 1/2" .. each 1/3

25/H1878a/906 per doz. —

25/H1878g/100 Rear 5 1/2" long x 1/2" .. each 1/6

25/H1878g/1106 per doz. —

Carrier Pattern.

25/H1878l/1300 6 1/2" long x 1/2" .. per doz. 19/6



"B.W." RACING HUB SPINDLES

Complete with cones and lock nuts.

For Nos. 19/20 "B.W." Continental Hubs.

No. 25/H1875g/108 Front each 2/4

25/H1875l/200 Rear 2/10

"B.H." AIRLITE HUB SPINDLES

Complete with Cones, Lock Nuts and Washers.

For Airlite or Airlite Continental Hubs.

For Front.

No. 25/H1866b/304 each 5/-

For Rear, Double sided.

No. 25/H1866c/308 each 5/6

For Rear, Derrailleur.

No. 25/H1866l/308 each 5/6

PRICES shown do NOT include PURCHASE TAX which will be charged at current rates where applicable

Branches
Aberdeen, Ayr, Belfast
Birmingham, Southampton
Bristol, Cardiff, Carlisle
Glasgow, Dublin, Dundee
London, Liverpool, Manchester
Newcastle, Perth

Head Office and Warehouse, Wholesale only.

GREAT EASTERN STREET, LONDON, E.C.2

125 GEORGE STREET EDINBURGH, 3

Branches
Liverpool, Manchester
Newcastle-upon-Tyne
Nottingham, Oxford, Preston
Reading, Southampton
Sheffield, Salford
Wolverhampton

HUB SPINDLES AND CONES

PHILLIPS HUB SPINDLES

Complete with Cones and Nuts.
Plated Finish.

On Display Cards of 1 dozen.

Front for No. 36 Hub.

No. (H1-15X.) per card
25/H1881m/907 14/4

Rear for Nos. 39 and 168 Hubs.

No. (H1-6X.) per card
25/H1881n/1007 15/11

Front for No. 167 Hub.

No. (H1-14X.) per card
25/H1881p/1000 15/-

Rear for No. 169 Hub.

No. (H1-10X.) per card
25/H1881r/1011 16/6

Rear for No. 170 Hub.

No. (H1-11X.) per card
25/H1881s/1208 19/-

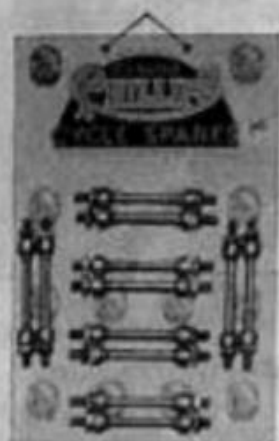

CYCLO REAR HUB SPINDLES

For converting ordinary hubs by changing over spindles.
With Cones (less washers) and Wide Locking Nut.
For Cycles or Tandems, No. 60.

No. 25/H1882t/202 6½" long each 3/1



CYCLO "ROSA" REAR HUB SPINDLES

Blue finish for converting ordinary hub by changing over spindle.
With extra long cones only 1" x 26 thread. Suitable for cycle tandem (as illustrated).

No. 25/H1883c/105 No. 61 6½" long. .. each 2/2

With special packing pieces, threaded (less cones).
7" long x 1/4" x 26 thread.

No. 25/H1883k/105 No. 62R. each 2/2

"B.B.L." HUB SPINDLES

Complete with Cones and Nuts.

Suitable for "Raleigh" (new pattern).

No. 25/H1888g/103 Rear each 1/10
25/H1888h/102 Front 1/9

Suitable for "Hercules" (Roadster).

No. 25/H1888w/1009 Front 5" long. .. per doz. 16/6
No. 25/H1888x/1109 Rear 6½" long. .. 18/-

HUB SPINDLES FOR FAIRYCYCLES

For Ball Bearing Hubs. Complete with Cones and Nuts.
1/8" dia. x 26 thread.

No. 25/H1890g/102 Front 4" long each 1/9
25/H1890h/104 Rear 5½" 2/-

No. 25/H1886b/605 5½" long per doz. 9/9
25/H1886f/700 7" 10/6



HUB SPINDLES ONLY

(Less Cones).

Bright Finish.

1" dia. x 26 thread.

5½" long per doz. 9/9

7" 10/6



STANDARD PATTERN HUB CONES

with Flat Backs.

For use with lock nuts.

"B.B.L." Best Quality. Nickel Plated.

Fixed Pattern.

No. 25/H1934a/21 Front each
25/H1934a/200 per doz.
25/H1934b/21 Rear each
25/H1934b/200 per doz.

Adjusting Pattern.

No. 25/H1934c/21 Front each
25/H1934c/200 per doz.
25/H1934d/21 Rear each
25/H1934d/200 per doz.

Cyclo "ROSA" Extra Long Hub Cones.

To suit Deraileur Gears.

1½" long for Left-hand side.

No. 25/H1942a/6 each 9

1½" long for Right-hand or Cham side.

No. 25/H1942b/6 each 9



STANDARD PATTERN HUB CONES

with Round Collars.

Fixed Pattern.

"B.B.L." Best Quality. Nickel Plated.

No. 25/H1920a/3 Front .. each -4
25/H1920a/200 .. per doz. —
25/H1920b/3 Rear .. each -4
25/H1920b/200 .. per doz. —

"Phillips" Plated.

Front No. H2-12.

No. 25/H1927p/210 .. per doz. 4/3

Rear No. H2-1.

No. 25/H1927s/210 .. per doz. 4/3

"B.B.L." "Raleigh" Pattern Black.

Front.

No. 25/H1930s/202 .. per doz. 3/3

Rear.

No. 25/H1930t/205 .. per doz. 3/9



STANDARD PATTERN HUB CONES

with Round Collars.

Adjusting Pattern.

"B.B.L." Best Quality. Nickel Plated.

No. 25/H1920c/3 Front .. each -4

25/H1920c/200 .. per doz. —

25/H1920d/3 Rear .. each -4

25/H1920d/200 .. per doz. —

"Phillips" Plated.

Front No. H2-11.

No. 25/H1927r/210 .. per doz. 4/3

Rear No. H2-2.

No. 25/H1927u/210 .. per doz. 4/3

"B.B.L." "Raleigh" Pattern Black.

Front.

No. 25/H1930f/202 .. per doz. 3/3

Rear.

No. 25/H1930h/205 .. per doz. 3/9

PRICES shown do NOT include PURCHASE TAX which will be charged at current rates where applicable

Branches:
Aberdeen, Aston, Belfast
Birmingham, Bournemouth
Bristol, Cardiff, Carlisle
Croydon, Dublin, Dundee
Exeter, Glasgow
Hull, Ipswich, Leeds

Head Office and Warehouse, Wholesale only:

GREAT EASTERN STREET, LONDON, E.C. 2

136 GEORGE STREET EDINBURGH, 2

Branches:
Liverpool, Manchester
Newcastle-upon-Tyne
Nottingham, Oxford, Preston
Reading, Southampton
Sheffield, Wakefield
Whitehaven

HUB NUTS WING NUTS



**CYCLO SERRATED CONE
LOCKING WASHER**

Prevents wheel from pulling over, specially made for drop-out fork ends without adjusters.

Screwed $\frac{1}{2}$ " \times 26 thread.
 $\frac{1}{4}$ " dia. \times $\frac{1}{2}$ " thick.
Gun-black Finish

No. 25/H1950a/7 .. per pair 1/10
25/H1950a/608 .. doz. pair —

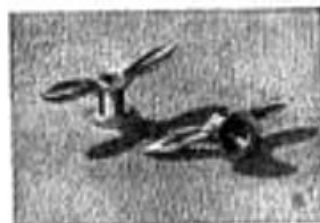

**REYNOLDS BUTTERFLY
ALUMINIUM RR.56 WING NUTS**
With hardened-serrated steel swivel washer.
Polished Standard Thread.

No. 25/H1979a/309 Front per pair 5/6
25/H1979b/309 Rear .. 5/6



"B.B.L." ALLOY WING NUTS

With hardened serrated steel swivel washer.
Standard thread.
Polished Alloy Finish.

No. 25/H1979w/102 Front per pair 1/9
25/H1979w/1308 doz. pair —

No. 25/H1979x/102 Rear per pair 1/9
25/H1979x/1308 doz. pair —



**"B.W." LIGHTWEIGHT
WING NUTS**

With cut-out wings. Chromium Plated.
No. 25/H1982p/1109 Front doz. pairs 17/6
25/H1982r/1109 Rear .. 17/6



HEXAGON CONE LOCK NUTS

"B.B.L."

(Flat without collar.)

Front $\frac{1}{4}$ ". Rear $\frac{1}{2}$ " \times 26 thread.

Cadmium Plated.

No. 25/H1950c/104 Front per doz. 2/-
25/H1950d/104 Rear .. 2/-

"B.S.A." Genuine.

Black Finish.

No. 25/H1950p/108 Front per doz. 2/6
25/H1950r/108 Rear .. 2/6



**SERRATED CONE
LOCK NUTS**

(Without collar.)

Hexagon shape in hardened steel.

Cadmium Plated.

No. 25/H1950t/200 .. per doz. 3/-



"B.B.L." WING NUTS

With hardened serrated swivel washer.
Standard thread.

With squared body to use with spanner if required.

Light Club Model Cut-out.

Chromium Plated.

Front.

No. 25/H1979p/102 .. per pair 1/9

Rear.

No. 25/H1979r/102 .. per pair 1/9

"G.B." LIGHT ALLOY WING NUTS

Fitted with serrated steel washers.

Highly Polished Finish.

No. 25/H1987p/300 Front per pair 4/6

25/H1987r/300 Rear .. 4/6

Special Rear Wing Nuts to suit
"S.A." Gears.

No. 25/H1987t/308 .. per pair 5/6



NUTS FOR FRONT HUB SPINDLES

"B.S.A." size, $\frac{1}{2}$ " \times 26 thread.

"B.B.L."

Chromium Plated.

No. 25/H1961g/100 .. per doz. 1/6
25/H1961g/1100 .. per gross —

Nickel Plated.

No. 25/H1961k/9 .. per doz. 1/3
25/H1961k/800 .. per gross —



NUTS FOR REAR HUB SPINDLES

Size, $\frac{1}{2}$ " \times 26 thread.

"B.B.L."

Chromium Plated.

No. 25/H1965g/104 .. per doz. 2/-
25/H1965g/1500 .. per gross —

Nickel Plated.

No. 25/H1965k/100 .. per doz. 1/6
25/H1965k/1100 .. per gross —



**CONSTRICTOR "GONLOY"
WING NUTS**

With serrated swivel washer.

Polished Alloy Finish.

No. 25/H1986m/204 Front per pair 5/-
25/H1986n/304 Rear .. 5/-



LEVER HUB WING NUTS

With hardened Serrated Swivel Washer.

Chromium Plated.

No. 25/H1979k/104 Front per pair 2/-
25/H1979k/1500 doz. pair —

No. 25/H1979l/104 Rear per pair 2/-
25/H1979l/1500 doz. pair —

PRICES shown do NOT include PURCHASE TAX which will be charged at current rates where applicable

Branches
Aberdeen, Aston, Bristol
Birmingham, Bournemouth
Bradford, Cardiff, Carlisle
Coventry, Dublin, Dundee
Exeter, Glasgow
Hull, Liverpool, Leeds

Head Office and Warehouse, Whitehall only

GREAT EASTERN STREET, LONDON, E.C.2

125 GEORGE STREET EDINBURGH, 1

Branches
Liverpool, Manchester
Newcastle-upon-Tyne
Nottingham, Oxford, Preston
Reading, Southampton
Sheffield, Tyneside
Wolverhampton

HUB REPAIR PARTS—continued

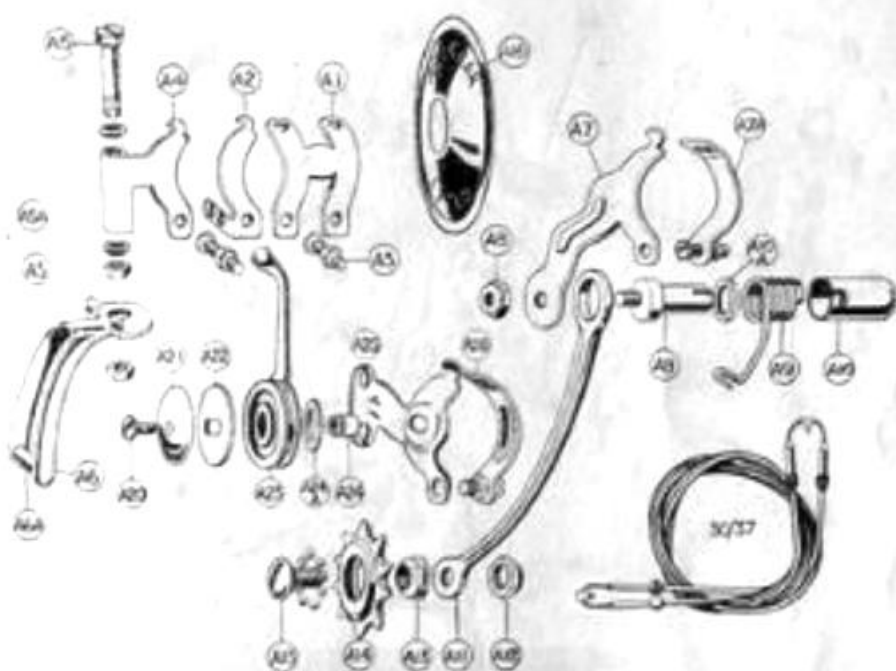

CYCLO "ACE" DERAILLEUR GEAR SPARES.

No. 25/HA1 6	Front Chain Stay Clip, A1 .. each	-9	No. 25/HA13/504	Conn for Tension Sprocket .. doz.	8/-
25/HA2 4	Rear Clip R.H. Side, A2	-6	25/HA14/103	Tension Sprocket only (10th), A14	each 1/11
25/HA3 2	Pin and Nut for above, A3	-3	25/HA14a/208	Tension Sprocket (complete), A14a	3/9
25/HA4 8	Rear Swivel Clip L.H. Side, A4 ..	1/-	25/HA15 8	Tension Sprocket Spindle, A15 ..	1/-
25/HA5 8	Swivel Bolt, and Lock Nuts, A5 ..	1/-	25/HA7/15/700	Tension Arm (complete), A7/15 ..	10/6
25/HA5a/104	Swivel Bolt Fibre Washer, A5a doz. pr.	2/-	25/HA16/10	Spoke Protector Disc, A16	1/3
25/HA6/108	Selector Fork only, A6 each	2/6	25/HA20/104	Lever Centre Screw, A20 doz.	2/-
25/HA6a/208	Selector Fork Bush, A6a doz.	4/-	25/HA21/208	Lever Spring Friction Plate, A21 ..	4/-
25/HA1 6a/309	Selector Fork Unit (Complete), A1/6a	each 5/7	25/HA22/104	Lever Large Washer, A22	2/-
25/HA7 9	Arm Anchorage Clip, A7	1/2	25/HA23/108	Lever Banjo, A23 each	2/6
25/HA7a 2	Arm Anchorage Half Clip, with Pin and Nut, A7a	-3	25/HA24/104	Lever Rivet, A24 doz.	2/-
25/HA8/10	Spring Shaft Bolt and Nut, A8 ..	1/3	25/HA24a/104	Lever Small Washer, A24a	2/-
25/HA9 6	Tension Spring, A9	-9	25/HA25/504	Lever Back Plate, A25	8/-
25/HA10 4	Tension Spring, Dust Cover, A10 ..	-6	25/HA26 4	Lever Half Clip with Pin and Nut, A26	each -6
25/HA10a/104	Felt Washer for above, A10a doz. pr.	2/-	25/HA20/26/400	Lever complete, A20/26	6/-
25/HA11/106	Tension Arm only each	2/3	25/HA30/37/206	Cable complete, A30/37	3/9
25/HA12/304	Nut for Tension Sprocket, A12 doz.	5/-			

For
CYCLO "ACE" DERAILLEUR GEARS COMPLETE
Please refer to Page 108.

PRICES shown do NOT include PURCHASE TAX which will be charged at current rates where applicable

Branches
Aberdeen, Arlon, Belfast
Birmingham, Bournemouth
Bristol, Cardiff, Carlisle
Croydon, Dublin, Dundee
Exeter, Glasgow
Hull, Inverness, Leeds

Head Office and Warehouse, Wholesale only

GREAT EASTERN STREET, LONDON, E.C. 2
124 GEORGE STREET EDINBURGH. 2

Branches
Liverpool, Manchester
Newcastle-upon-Tyne
Nottingham, Oxford, Preston
Reading, Southampton
Stock-on-Trent
Wolverhampton

HUB REPAIR PARTS—continued

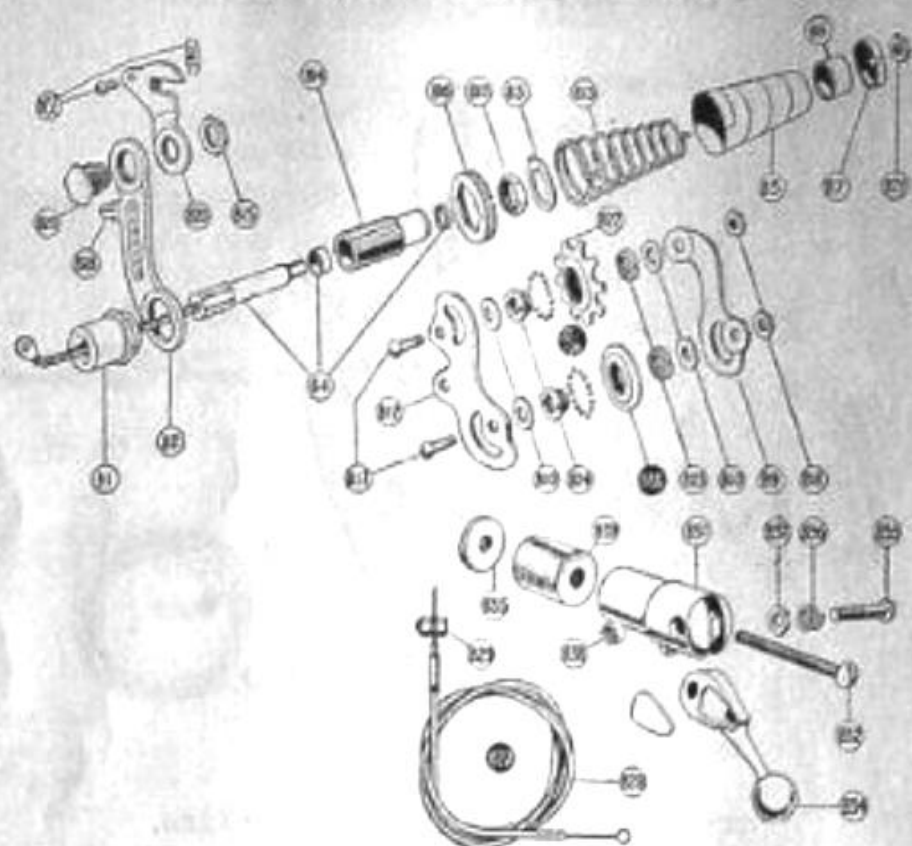

CYCLO "BENELUX" 3-, 4- OR 5-SPEED DERAILLEUR GEAR SPARES.

No. 25/104	Outside Dorned Adjusting Nuts.	No. 25/108	10 T. Jockey Sprocket, B22 .. each	2
25/400	B1 each	25/100	Cone Screw, B23	1
25/208	Arm, B2 6/-	25/4	Cone Nut, B24	1
25/204	Tab Washer, B3 doz.	25/38/700	Benelux Handlebar Control	
	Op. Shaft complete with Op. Chain		Lever complete, B27/39	10
	Link Screw Nuts and Washers.		For 3-speed $\times \frac{1}{4}$ "	} Please state when ordering.
25/100	B4 each		For 4-speed $\times \frac{1}{4}$ "	
25/6/4	Volute Spring, B5 1/6		For 4-speed $\times \frac{3}{8}$ "	
25/7/4	Thimble, B6 -/6		For 5-speed $\times \frac{3}{8}$ "	
25/208	Spring Ret. Cup (small), B7 -/6	25/204	Cable Complete, B27	3
25/208	Pulley Nut, B8 doz.	25/100	Outer Casing only, length 5' 6"	
25/9/8	Rear Guide Plate, B9 each		Silver Grey, B28	1
25/10/104	Packing Washer, $\frac{1}{4}$ " Chain only.	25/104	Inner Wire with Adjuster and	
	B10 doz.		Nipple, B29	2
25/11/4	Pulley Ret. Pin, B11 each	25/200	Handlebar Inverted Member,	
25/11a/206	Roller Tension complete, B11a 3/9		B30	3
25/100	Front Guide Plate, B12 1/6	25/4	Handlebar Rubber Cushion, B31	
25/2a/3	Rosa stop guide pin -/5	25/104	Handlebar Centre Pin, B32 doz.	2
25/100	Taper Tension Spring, B13 1/6	25/104	Handlebar Centre Washer, B33	2
25/104	Adj. Sleeve, B14 3/6	25/204	Trigger Knob, B34 each	3
25/208	Quick Release Nut doz.	25/104	Trigger Pivot Pin, B35 doz.	2
25/104	Spring Ret. Cup (large), B16 each	25/2	Spring Washer, B36 each	
25/208	Spigot Adj. Nut, B17 doz.	25/2	Hex. Friction Pad, B37	
25/104	Cable Stop, B18 each	25/2	Pivot Pin Lock Nut, B38	
25/100	Quick Release Bolt, B19 1/6	25/108	Top Tube Control Cable Solo	2
25/100	Arm Bracket, B20 1/6	25/206	Top Tube Control Cable Tandem	2
25/208	Op. Shaft Nut, B21 doz.	25/304	Top Tube Control Quadrant	
25/22/24/208	Jockey Sprocket complete, B22/24 each		complete	5

For
CYCLO "BENELUX" DERAILLEUR GEARS COMPLETE
Please refer to Page 109.

PRICES shown do NOT include PURCHASE TAX which will be charged at current rates where applicable

Branches
Birmingham, Aston, Bolton
Bristol, Cardiff, Carlisle
Croydon, Dublin, Dundee
Exeter, Glasgow
Newcastle, Leeds

Head Office and Warehouse, Wholesale only:

GREAT EASTERN STREET, LONDON, E.C.2

125 GEORGE STREET, EDINBURGH, 2

Branches
Liverpool, Manchester
Newcastle-upon-Tyne
Nottingham, Oxford, Preston
Reading, Southampton
Sheffield, Truro
Wolverhampton

HUB REPAIR PARTS—continued (Accessories)



CYCLO CHAIN STAY CLIPS
Detachable for $\frac{1}{2}$ ", $\frac{1}{4}$ " and $\frac{1}{8}$ " Round Stays.
Complete with Clip and Bracket.

No. 25/HC80a/205 each 3/8
Bracket only (B/L).
No. 25/HC80b/105 each 2/2
Clip only (O/C).

No. 25/HC80c/100 each 1/6
Liners for $\frac{1}{4}$ " Round Brackets.
No. 25/HC80et/2 per pair—/3

CYCLO "UNIVERSAL" BRACKET

For Standard 3- and 4-speed Gear,
will suit any type of fork end or
chain stay.

No. 25/HC93/200 .. each 3/-



CYCLO HUB COGS FOR DERAILLEUR GEARS

Please see page 114.



CYCLO DETACHABLE AND ADJUSTABLE BRAZED ON BRACKET

No. 25/HC97/108 No. T/E and B/L each 2/3

CYCLO RECONDITIONED CABLES OR TRANSMISSIONS

Waterproof Covered.

For Cycle, No. 30P.

No. 25/HC30p/200 each 3/-

For Tandem, No. 30R.

No. 25/HC30r/200 each 3/9

We can exchange from stock reconditioned cable units for broken or worn cables at above prices.

CYCLO "ROSA" TENSION SPROCKET CHAIN GUARD

(Illustration shows guard fitted to system.)

No. 25/HC155/604 doz. 8/-



CYCLO TWIST GRIP CONTROL

Complete with Twist Grip, Dammy to match and transmission.

Suitable for 2-, 3- and 4-speed Derailleur Gears.

For Solo Machines.

No. 25/HC160a/804 each 12/6

For Gent's Tandem.

No. 25/HC160L/900 each 13/6

For Tandem Lady's Rear.

No. 25/HC160m/800 each 13/6

CYCLO SPANNER

To fit all requirements on Cycle Gears.

No. 25/HC100/8 No. 38 .. each 1/-



CYCLO "ROSA" TENSION PULLEY
With Dural Flanges.

Eliminates the possibility of chain jumping.

No. 25/HC200p/400 each 6/-

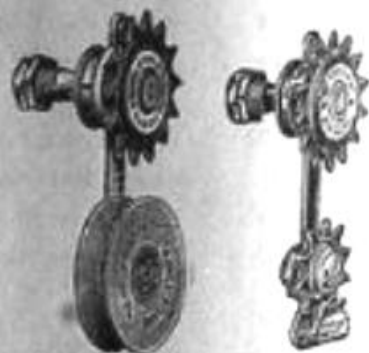

CYCLO DERAILLEUR GEAR SYSTEMS

Sprocket type for 2-speed Gears.

No. 25/HC200a/1103 each 16

Pulley type for 2-speed Gears.

No. 25/HC200g/1201 each 17

Sprocket type for 3-speed Gears.

No. 25/HC201a/1103 each 16

Pulley type for 3-speed Gears.

No. 25/HC201g/1201 each 17

25/HC201L/1608 Dural 25

PRICES shown do NOT include PURCHASE TAX which will be charged at current rates where applicable

Branches
Aberdeen, Aston, Belfast
Birmingham, Bury, Dundee
Aston, Cardiff, Carlisle
Croydon, Dublin, Exeter
Leeds, Liverpool, Glasgow
Newcastle, London

Head Office and Warehouse, Wholesale only

GREAT EASTERN STREET, LONDON, E.C.2

126 GEORGE STREET EDINBURGH, 2

Branches
Liverpool, Manchester
Hemel Hempstead, York
Newcastle, Oxford, Preston
Reading, Southampton
Sutton-Tram, Wakefield

HUB REPAIR PARTS—continued

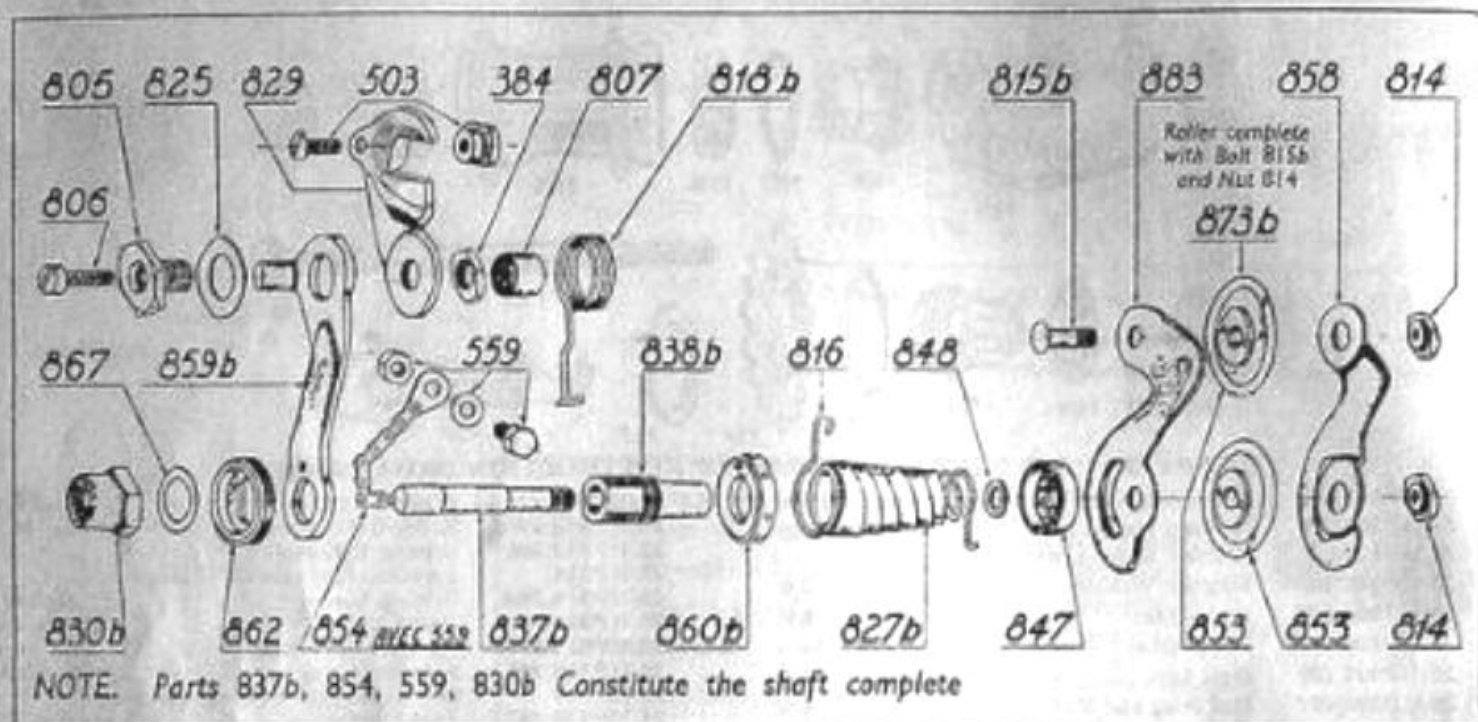
SIMPLEX "TOUR DE FRANCE" DERAILLEUR GEAR SPARES
(Continental make.)Control Lever Assembly.
(Not illustrated.)

No. 25/HS125/700	Control Lever, complete with wire and casing	each 10/6
25/HS126/508	Control Lever Assembly	8/6
25/HS127/100	Inner Wire	1/6
25/HS128/100	Outer Casing	2/3
25/HS129/202	Control Lever	3/3
25/HS134/134b/5	Bolt and Nut for Control Lever Clip	7
25/HS135/3	Centre Screw for Control Lever	4
25/HS137/6	Domed Friction Plate	9
25/HS137b/8	Domed Outer Plate	9
25/HS472/6	Dogged Washer	9
25/HS494/102	Sector Plate	1/9
25/HS560/103	Cable Adjusting Screw and Nut	1/10
25/HS598/200	Control Lever Clip	3/-
25/HS599/11	Brace on Bosses	1/4
25/HS651/6	Friction Washer	9
25/HS843/109	Wing bolt	1/6
Gear Assembly. (Illustrated.)		
25/HS241/1508	Gear Mechanism only for 3 or 4 speed	each 23/6
25/HS241a/1700	Gear Mechanism only for 5 speed only	25/6
25/HS384/4	Pivot Screw Lock Nut	6
25/HS503/408	Fixing Screw	doz. 7/-
25/HS504/408	Nut for fixing Screw	doz. 7/-
25/HS559/8	Draw Bolt complete	each 1/-
25/HS805/8	Pivot Nut	1/-
25/HS806/4	Pivot Screw	6
25/HS807/904	Tension Spring Holder	doz. 14/-
25/HS814/304	Roller Axle Nut	5/-
25/HS815b/400	Roller Axle	6/-

Gear Assembly—continued.

No. 25/HS816/1304	Traverse Springs	doz. 20/-
25/HS818b/1304	Tension Springs	doz. 20/-
25/HS825/104	Pivot Washer	2/-
25/HS827b/104	Dust Cover Spring	each 2/-
25/HS829/208	Fixing Plate	4/-
25/HS830b/1304	Domed Nut	doz. 20/-
25/HS837b/202	Shaft	each 3/3
25/HS837c/500	Shaft complete for 3 speed $\times \frac{1}{2}$ "	7/6
25/HS837d/500	Shaft complete for 4 speed $\times \frac{1}{2}$ "	7/6
25/HS837e/500	Shaft complete for 4 speed $\times \frac{3}{8}$ "	7/6
25/HS837f/500	Shaft complete for 5 speed $\times \frac{3}{8}$ "	7/6
25/HS838b/204	Adjusting Shaft Sleeve	3/6
25/HS847/8	Fixed Cup	9
25/HS848/104	Washer	doz. 2
25/HS853/108	Roller only	each 2/6
25/HS853a/100	Cones	pair 1/6
25/HS854/200	Toggle Chain	each 3/-
25/HS858/204	Roller Plate (dished)	3/6
25/HS859b/400	Carrying Arm	6
25/HS860b/108	Traverse Spring Holder	2/6
25/HS862/104	Knurled Adjuster	2
25/HS867/104	Washer for domed Nut	doz. 2
25/HS873b/300	Roller complete (with cones and bearings)	each 4/-
25/HS883/204	Roller Plate (flat)	3

SIMPLEX "TOUR DE FRANCE"
DERAILLEUR GEARS (Less Free Wheels)

Please refer to Page 110.

PRICES shown do NOT include PURCHASE TAX which will be charged at current rates where applicable

Branches
 Aberdeen, Acton, Belfast
 Birmingham, Bournemouth
 Bristol, Cardiff, Carlisle
 Clifton, Dublin, Dundee
 Exeter, Glasgow
 Hull, Ipswich, Leeds

Head Office and Warehouse, Wholesale only:

GREAT EASTERN STREET, LONDON, E.C.2

125, GEORGE STREET, EDINBURGH, 2

Branches
 Liverpool, Manchester
 Newcastle upon Tyne
 Nottingham, Oxford, Preston
 Reading, Southampton
 Stoke-on-Trent
 Wolverhampton

HUB REPAIR PARTS—continued

STURMEY-ARCHER HUB GEAR SPARES (EXPLODED VIEWS)

A list of all "S.A." Replacement Spares (in Alphabetical and Numerical Order) will be found on pages 134-136.
Interchangeability of Spares Chart on pages 137 and 138.

MODEL "A.W." WIDE RATIO THREE-SPEED HUB GEAR

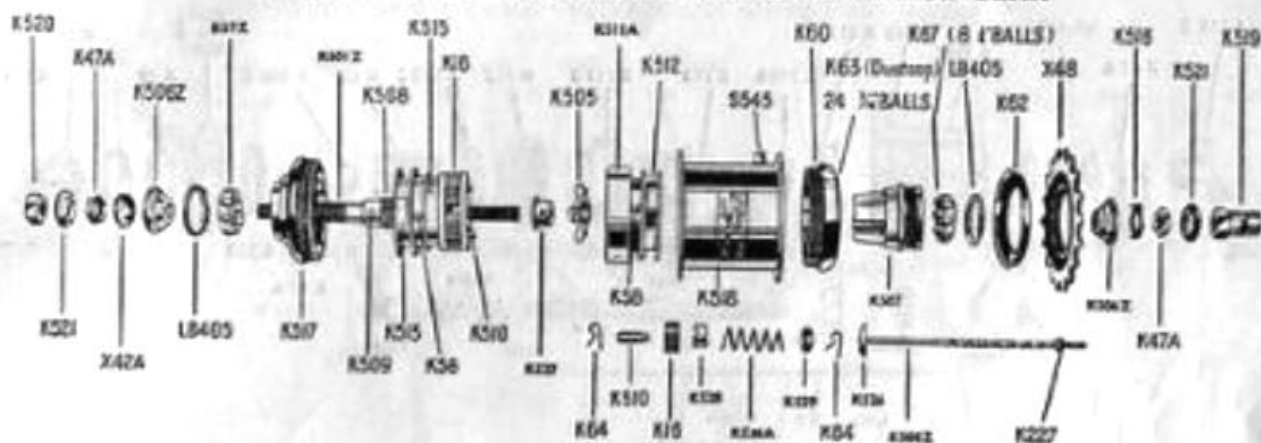

MODEL "A.M." MEDIUM RATIO THREE-SPEED HUB GEAR

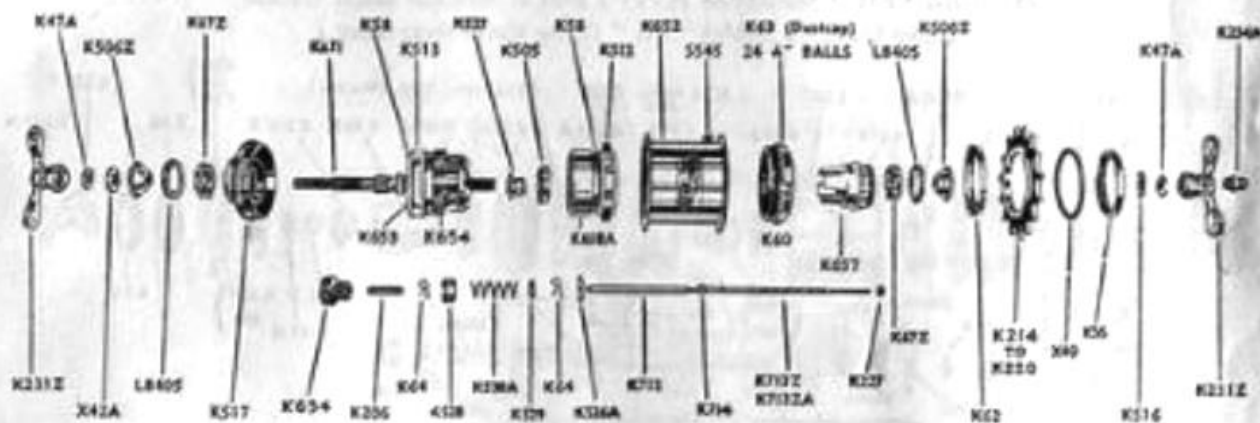

MODEL "A.C." ULTRA CLOSE RATIO THREE-SPEED HUB GEAR

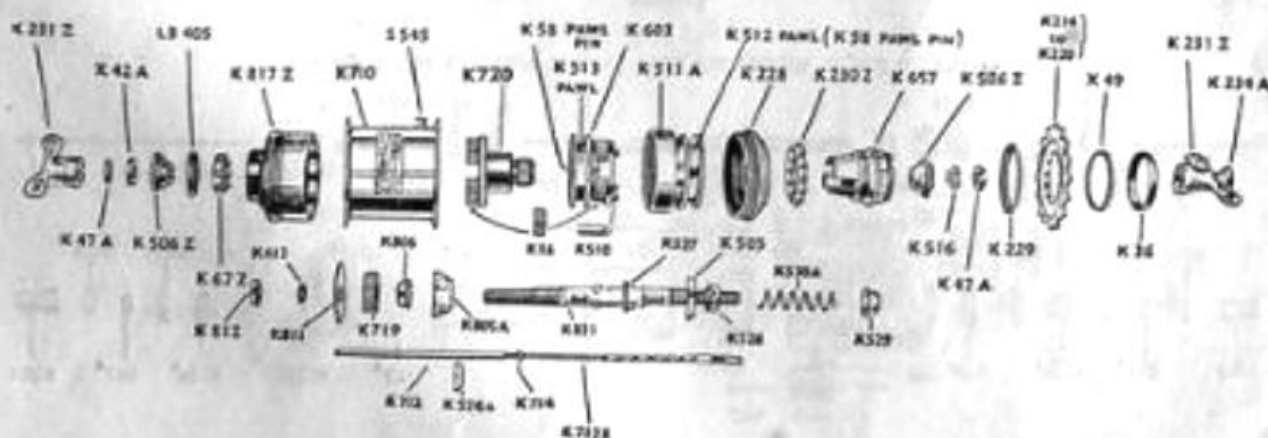

PRICES shown do NOT include PURCHASE TAX which will be charged at current rates where applicable

Branches
Aberdeen, Arrol, Belfast
Birmingham, Bournemouth
Bristol, Cardiff, Carlisle
Croydon, Dublin, Dundee
Edinburgh, Glasgow
Hull, Manchester, Leeds

Head Office and Warehouse, Wholesale only:

GREAT EASTERN STREET, LONDON, E.C. 2

124 GEORGE STREET EDINBURGH, 2

Branches
Liverpool, Manchester
Newcastle-upon-Tyne
Nottingham, Oxford, Preston
Reading, Southampton
Sheffield, Tyneside
Wolverhampton

HUB REPAIR PARTS—continued

STURMEY-ARCHER HUB GEAR SPARES (EXPLODED VIEWS)

A list of all "S.A." Replacement Spares (in Alphabetical and Numerical Order) will be found on pages 134-136.
Interchangeability of Spares Chart on pages 137 and 138.

MODEL "ASC" FIXED THREE-SPEED HUB

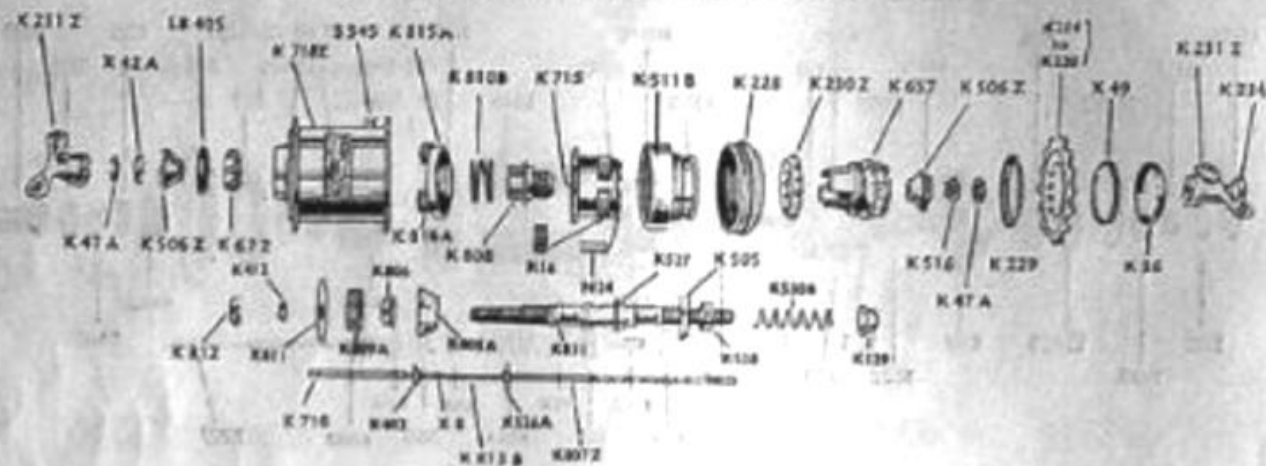

MODEL "FM" MEDIUM RATIO FOUR-SPEED HUB GEAR
(Also includes Model "FC" Close Ratio Hub Gear.)

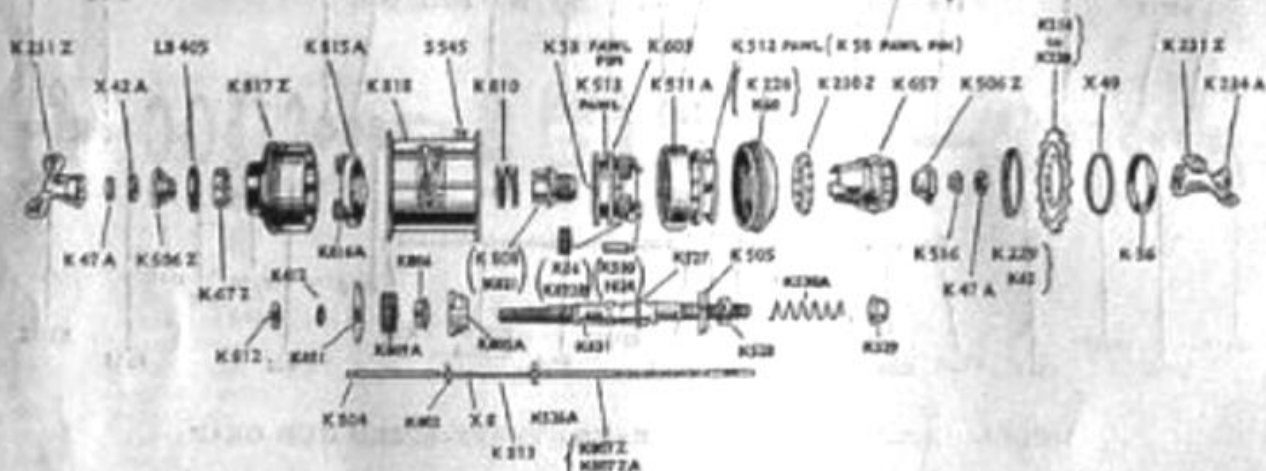

MODEL "FW" WIDE RATIO FOUR-SPEED HUB GEAR

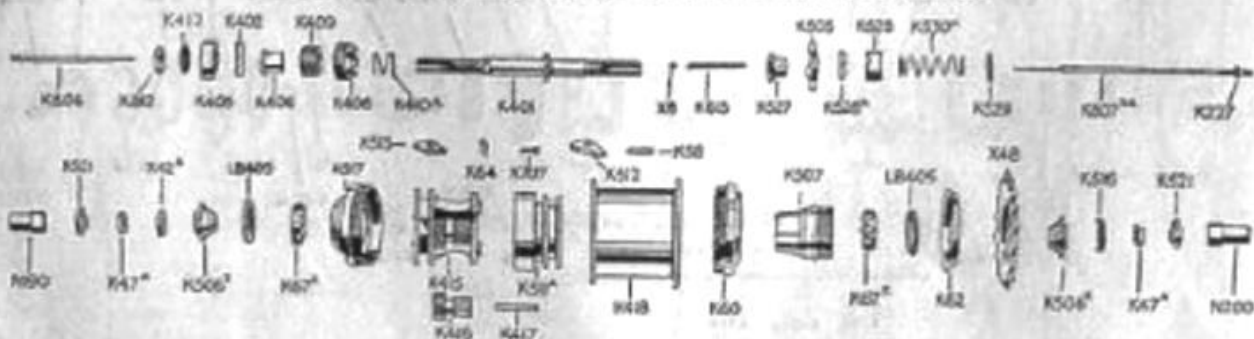

PRICES shown do NOT include PURCHASE TAX which will be charged at current rates where applicable

Branches:
Aberdeen, Aston, Belfast
Birmingham, Southampton
Bristol, Cardiff, Cardiff
Croydon, Dublin, Dundee
Exeter, Glasgow
Hull, Inverness, Leeds

Head Office and Warehouse, Wholesale only

GREAT EASTERN STREET, LONDON, E.C. 2

124 GEORGE STREET, EDINBURGH, 2

Branches:
Liverpool, Manchester
Newcastle-upon-Tyne
Nottingham, Oxford, Preston
Reading, Southampton
Sheffield, Tynes
Wolverhampton

HUB REPAIR PARTS—continued

STURMEY-ARCHER CONTROL SPARES (EXPLODED VIEWS)

FOR 3 AND 4 SPEED GEARS AND INTERNAL
EXPANDING HUB BRAKES

SPARES FOR CABLE CONTROL

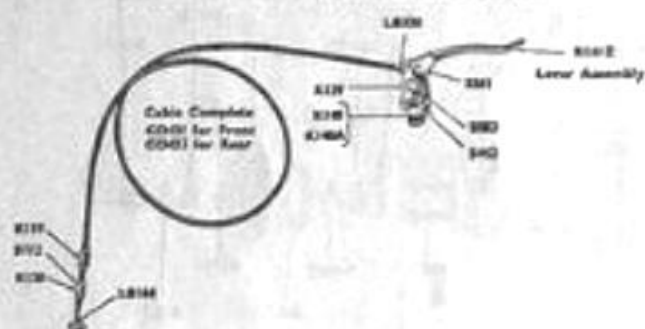

A LIST OF ALL "S.A." REPLACEMENT SPARES
(IN ALPHABETICAL AND NUMERICAL ORDER,
WILL BE FOUND ON PAGES 134-136.

INTERCHANGEABILITY OF SPARES CHART
ON PAGES 137 AND 138.

SPARES FOR "FLICK" TRIGGER CONTROLS

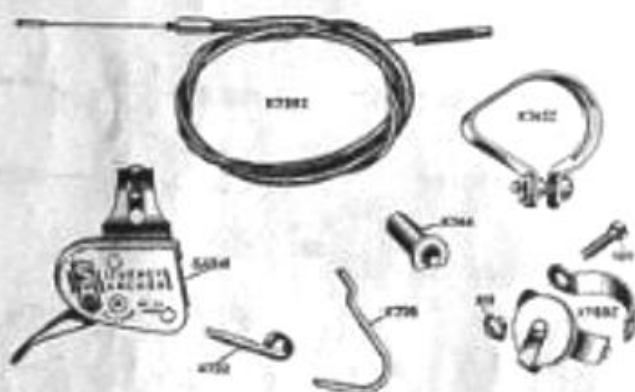

SPARES FOR TOP TUBE CONTROLS

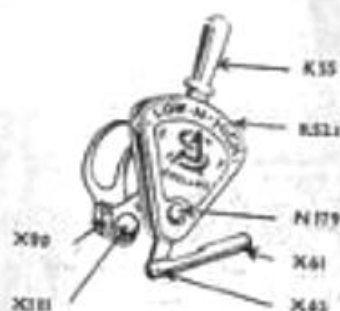

SPARES FOR ROD CONTROL

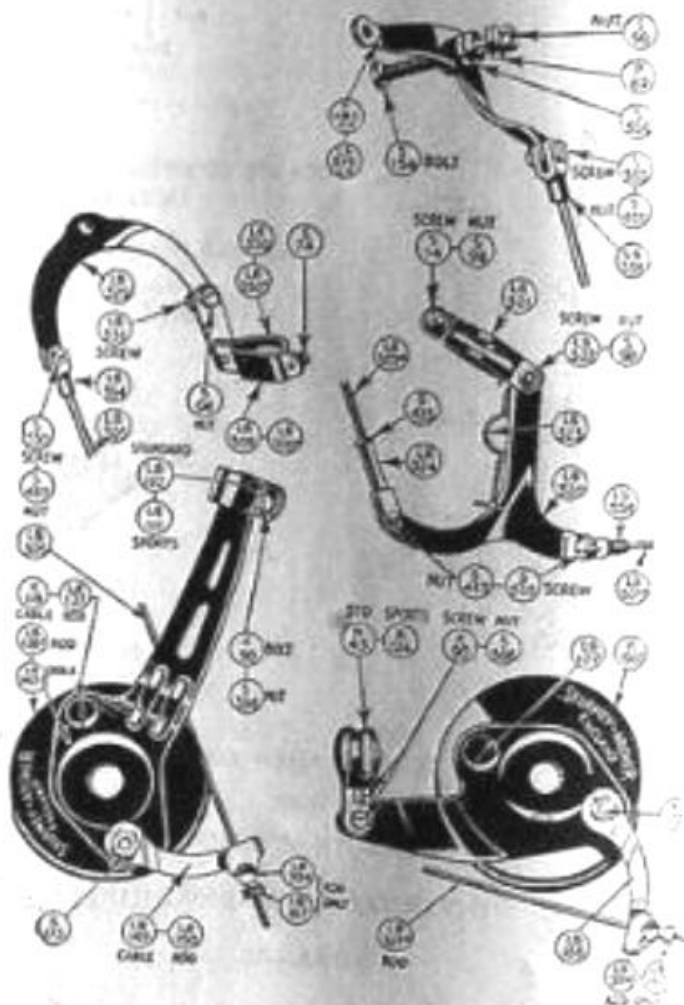

PRICES shown do NOT include PURCHASE TAX which will be charged at current rates where applicable

Branches:
Aberdeen, Acton, Belfast
Birmingham, Southampton
Bristol, Cardiff, Cardiff
Croydon, Dublin, Dundee
Edinburgh, Glasgow
Hull, Ipswich, Leeds

Head Office and Warehouse, Wholesale only

GREAT EASTERN STREET, LONDON, E.C.2

134 GEORGE STREET EDINBURGH 2

Branches:
Liverpool, Manchester
Newcastle-upon-Tyne
Nottingham, Oxford, Preston
Reading, Southampton
Sheffield, Tyneside
Wolverhampton

HUB REPAIR PARTS—continued

STURMEY-ARCHER DYNOHUB SPARES (EXPLODED VIEWS)

The exploded views show both Gear and Dynamo Spares. Gear Spares (In Alphabetical and Numerical Order) will be found on pages 134-136. Interchangeability of Spares Chart on pages 137 and 138.

Dynamo Spares (including Head and Tail Lamps): please see page 165.

Dynohubs complete... .. 145.

MODEL "GH6" FRONT DYNOHUB (6 VOLT)

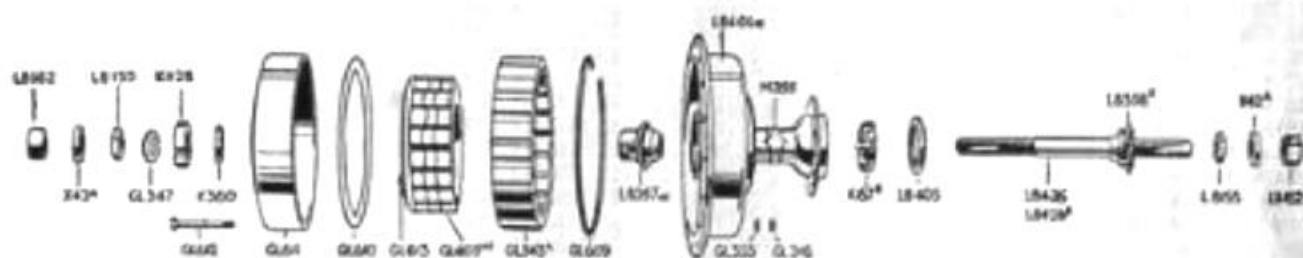

MODEL "AG" THREE-SPEED GEAR AND DYNOHUB COMBINED

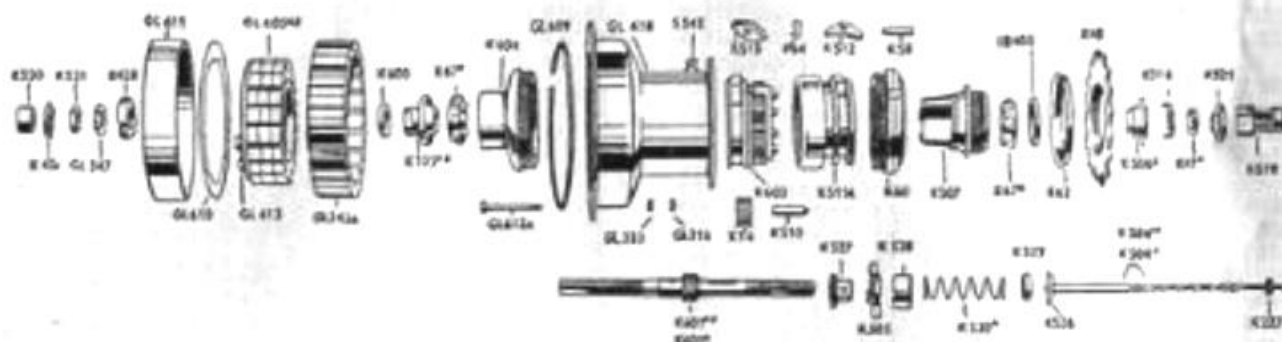

MODEL "FG" FOUR-SPEED GEAR AND DYNOHUB COMBINED

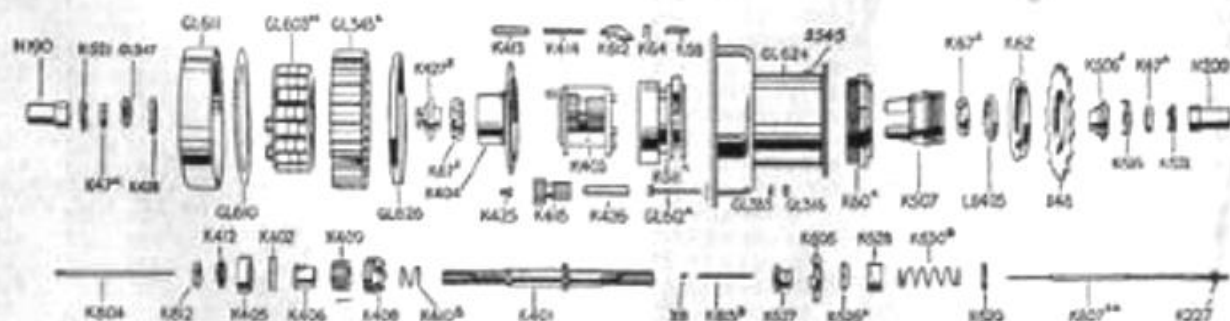

PRICES shown do NOT include PURCHASE TAX which will be charged at current rates where applicable

Branches
Aberdeen, Arisaig, Belfast
Birmingham, Bournemouth
Bristol, Cardiff, Carlisle
Croydon, Dublin, Dundee
Glasgow, Glasgow
Hull, Inverness, Leeds

Head Office and Warehouses, Wholesale only:

GREAT EASTERN STREET, LONDON, E.C. 2
124 GEORGE STREET EDINBURGH, 2

Branches
Liverpool, Manchester
Newcastle-upon-Tyne
Nottingham, Oxford, Preston
Reading, Southampton
Sheffield, Telford
Wolverhampton

LAMPS (Dynamo)



The "Universal"



The "Continental"



The "Popular"



The "Sportsman"

"BEMO" SILVER ATOM CYCLE DYNAMO LIGHTING SETS

Complete with torpedo streamlined head lamp with bulb. New Silver Atom 8 pole dynamo, heavy chromium plated on brass. With rear lamp and cable.

Head lamp main bulb, 6 volt, 0.3 amp., M.E.S. cap. Head lamp pilot bulb, 4 volt, 0.3 amp., M.E.S. cap. Tail lamp 6 volt., 0.4 amp., M.E.S. cap.

The "Universal" Set.

With battery type head lamp with switch, for twin bulbs, main and pilot (battery extra).

Silver enamel finish with chromium plated rim.

No. 25/L44e/2702 Model No. 450WT .. per set 41/-
All chromium plated, finish head lamp.

No. 25/L44f/2910 Model No. 451WT .. per set 44/9

The "Popular" Set.

With non-battery type head lamp, with main bulb only.

Silver enamel finish with chromium plated rim.

No. 25/L47e/2105 Model No. 460 WT .. per set 32/3

All chromium plated finish head lamp.

No. 25/L47f/2408 Model No. 461WT .. per set 37/-

Black enamel finish with chromium plated rim.

No. 25/L47g/2105 Model No. 460WT .. per set 32/3

The "Continental Twin" Set.

With non-battery type head lamp with switch, operating twin bulbs, main and pilot.

Silver enamel finish with chromium plated rim.

No. 25/L46e/2008 Model No. 462WT .. per set 31/-

All chromium plated finish head lamp.

No. 25/L46f/2703 Model No. 463WT .. per set 41/-

The "Sportsman" Set.

With non-battery type head lamp, with main bulb only.

All chromium plated finish head lamp.

No. 25/L48f/2408 Model No. 471WT .. per set 37/-

Dynamo Rear Lamps.

Small round type with domed lens.

No. 25/L48t/203 Model No. RI49 .. each 4/11



"SPARTO" DYNAMO REAR LAMPS

With red plastic dome $\frac{1}{2}$ " dia. extended to give light to rear and side.

Less bulb and cable.

Packed in display cartons of 1 dozen.

Polished Aluminium No. 1106A.

No. 25/L53a/102 .. each 1/9

Chromium Plated No. 1106.

No. 25/L53d/104 .. each 2/-



"SPARTO" DYNAMO SPOTLIGHT HEAD LAMP

With adjustable focus for parallel or conical beam. $4\frac{1}{2}$ " front silvered reflector fitted with unbreakable domed lens. Weight $4\frac{1}{2}$ oz. Less bulb and lens cable.

Silver grey finish.

No. 25/L54a/804 .. each 12/6

Chromium plated.

No. 25/L54t/908 .. each 14/6



"SPARTO" MARK IV DYNAMO HEAD LAMP

All chromium plated with polished alloy bracket, 1" dia. round body, $2\frac{1}{2}$ " long overall, including hooded section, fitted with special plastic clear lens. Less bulb and cables.

Weight 3 oz.

No. 25/L54e/204 .. each 3/6

"ROAD CHIEF" DYNAMO REAR LAMP

Less bulb and lens cable. With universal clip. Silver finish.

No. 25/L54w/103 .. each 1/11

25/L54w/1503 .. per dot --

"BRITAX" DYNAMO REAR LAMP

All plastic body with red $\frac{1}{2}$ " dia. dome. Complete with adjustable clip for rear stays.

Less bulb and cable.

No. 25/L52w/102 .. each 1/9

PRICES shown do NOT include PURCHASE TAX which will be charged at current rates where applicable

Branches
Aberdeen, Aston, Belfast
Birmingham, Bournemouth
Bristol, Cardiff, Carlisle
Croydon, Dublin, Dundee
Eastbourne, Glasgow
Hull, Inverness, Leeds

Head Office and Warehouse, Wholesale only:

GREAT EASTERN STREET, LONDON, E.C. 2

124 GEORGE STREET EDINBURGH, 2

Branches
Liverpool, Manchester
Newcastle-upon-Tyne
Nottingham, Oxford, Preston
Reading, Southampton
Sheffield, Tinsley
Wolverhampton

LAMPS (Dynamo)—continued

LUCAS DYNAMO LIGHTING SETS (Complete with Bulbs and twin cable. Less Batteries).

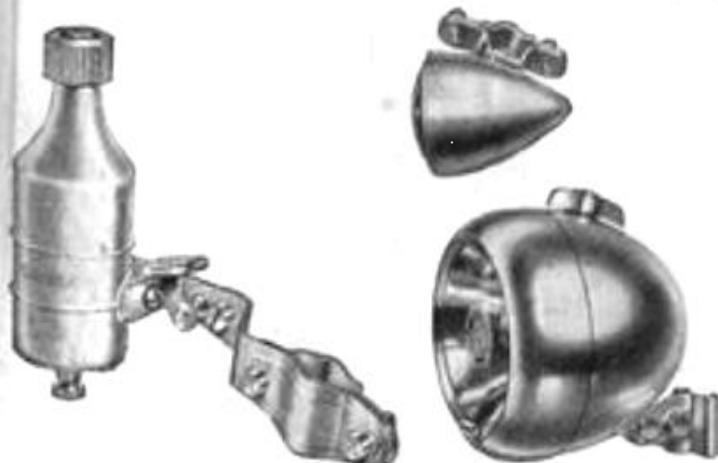

Lucas Model 353 Set.

Streamlined Battery type Head Lamp, No. 313 (to take No. 305R Battery), with three-position switch operating Main and Pilot Bulbs, includes new type fluted reflector. No. 845 Rear Lamp and CD33 Dynamo combined. Silver and Chromium Finish.

No. 25/L81k/2500 per set 37/6

Lucas Model 313CM Set. For Motorised Cycles.

As above, but with Rear Lamp VT31CA to illuminate number plate. No. 25/L81kc/2500 per set 37/6

Head Lamp only. No. 313.

No. 25/L81L/1108 each 17/6

Head Lamp No. 313 and Rear Lamp No. 845.

No. 25/L81Lr/1404 each 21/6



Lucas Model 853 Set.

Streamlined Battery type Head Lamp, No. 318 (to take No. 305R Battery), with three-position switch operating Main and Pilot Bulbs, includes new type fluted reflector No. 845 Rear Lamp in Silver finish and CD33 Dynamo.

Chromium Plated Head Lamp.

No. 25/L81m/2800 per set 42/-

Head Lamp only. No. 318.

No. 25/L81n/1404 each 21/6

TWIN WIRING

All "Lucas" Dynamo Sets now incorporate twin wiring (insulated return system) which eliminates wiring troubles and the necessity of scraping enamel from the frame. These twin cables are sealed in a silver finish plastic waterproof covering.



Lucas Model 663 Set.

Non-battery type Head Lamp No. 596, with Main Bulb and fluted reflector. With No. 66 Rear Lamp specially constructed for all-round visibility, and No. CD33 Dynamo.

All Chromium Plated Head Lamp.

No. 25/L82c/2108 per set 32/6

Silver and Chrome Head Lamp.

No. 25/L82d/2000 per set 30/-

Lucas Rear Lamp No. 66.

One piece body and adjustable stay clip.

No. 25/L82e/200 each 3/-



Lucas Model 453 Set.

With battery-type Head Lamp No. 304 (to take No. 305R Battery) fitted with shockproof rubber bracket. No. 845 Rear Lamp and CD33 Dynamo combined. Complete with Main and Pilot Bulbs. Black and Chromium Plated finish.

No. 25/L84m/2500 per set 37/6

Lucas Model 413CM Set. For Motorised Cycles.

As above, but with Rear Lamp VT31CA to illuminate number plate. No. 25/L84mc/2500 per set 37/6

Head Lamp only. No. 304.

Black finish with Chromium Plated Rim.

No. 25/L84n/1100 each 16/6

PRICES shown do NOT include PURCHASE TAX which will be charged at current rates where applicable

Branches
Aberdeen, Acton, Belfast
Birmingham, Bournemouth
Bristol, Cardiff, Exeter
Glasgow, Dublin, Dundee
Leeds, Liverpool, Glasgow
Hull, Manchester, Leeds

Head Office and Warehouse, Wholesale only:

GREAT EASTERN STREET, LONDON, E.C.2

126 GEORGE STREET EDINBURGH, 1.

Branches
Liverpool, Manchester
Newcastle-upon-Tyne
Nottingham, Oxford, Preston
Reading, Southampton
Stock-on-Trent
Wolverhampton

LAMPS (Dynamo)—continued

STURMEY-ARCHER PATENT 6 volt DYNAMO LIGHTING SETS

Supplied complete with Lamps (non-battery type), Bulbs, Cable and fittings. Packed in strong carton with complete instructions for fitting. All Hubs Chromium Plated.

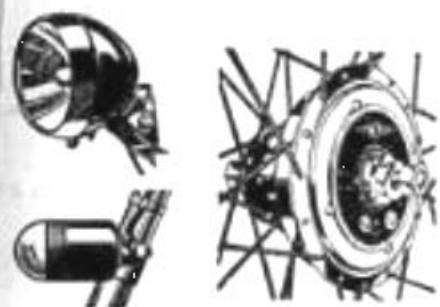

MODEL GH6 SET

For Front Wheel only.

Black and Chromium Plated Head Lamp.

No. 25/L220b/3208 .. per set 45/-

Silver and Chromium Plated Head Lamp.

No. 25/L220d/3208 .. per set 45/-

DRY BATTERY UNITS

For all above sets.

Size 9" x 1 1/4". To take 3 U2 type Batteries.

Complete with cables but less batteries.

For Model GH6.

All Black Finish.

No. 25/L223a/801 each 11/6

Black and White Finish

No. 25/L223b/801 each 11/6

For Models AG and FG.

All Black Finish.

No. 25/L223c/801 each 11/6

Black and White Finish.

No. 25/L223d/801 each 11/6

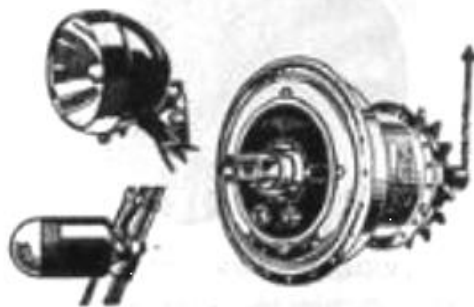

MODEL FG SET

For Rear Wheel.

With FW. 4-speed Gear.

Black and Chromium Plated Head Lamp.

No. 25/L222b/5011 .. per set 78/6

Silver and Chromium Plated Head Lamp.

No. 25/L222d/5011 .. per set 78/6

TAIL LAMPS ONLY

For all above sets.

With red plastic dome.

Complete with bulb, less cable.

For Round Stays.

No. 25/L221m/110 1/2" .. each 2/9

25/L221p/110 1/2" 2/9

For "D" Stays.

No. 25/L221r/110 each 2/9

For Oval Stays.

No. 25/L221s/110 each 2/9

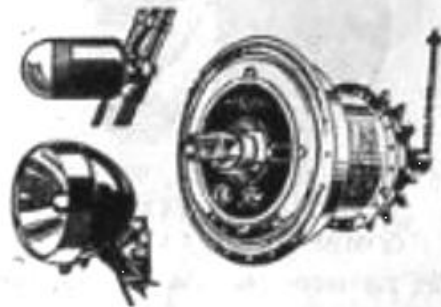

MODEL AG SET

For Rear Wheel.

With AW. Wide Ratio 3-speed Gear.

Black and Chromium Plated Head Lamp.

No. 25/L221b/5009 .. per set 70/-

Silver and Chromium Plated Head Lamp.

No. 25/L221d/5009 .. per set 70/-

HEAD LAMPS ONLY

Non-battery type with Chromium Plated Rim.

Complete with Bulb.

For Model GH6.

Black Enamelled.

No. 25/L220g/904 each 14/-

Silver Enamelled.

No. 25/L220h/904 each 14/-

For Models AG and FG.

Black Enamelled.

No. 25/L221g/904 each 14/-

Silver Enamelled.

No. 25/L221h/904 each 14/-

CORRECT RATING OF BULBS

Front Lamp.

Front wheel operation 6 volt, 0.3 amp.

Rear wheel operation 6 volt, 0.25 amp.

Rear Lamp.

For Front and Rear wheel operation 6 volt, 0.04 amp.

Replacement Spares.

Dynamo spares for "S.A." Dynohubs, refer to page 165.

For Gear Spares refer to "S.A." Hub Spares Section.

For Dynohubs built up into wheels refer to Completed

Bicycle Section.

WHEEL BUILDING

Spoke lengths may vary from other hubs and the following chart gives the lengths recommended for the normal types and sizes of rims.

Rim Type and Size	GH6.		AG and FG.	
	Small Flange	Large Flange	Small Flange	Large Flange
Westwood 28" x 1 1/4"	12 1/2"	11 1/2"	11 1/2"	11 1/2"
" 26" x 1 1/4"	11 1/2"	10"	11"	11"
" 26" x 1 1/4"	11 1/2"	10 1/2"	11 1/2"	11 1/2"
Endrick 26" x 1 1/4"	11 1/2"	10 1/2"	11 1/2"	11 1/2"
" 26" x 1 1/4"	11 1/2"	10 1/2"	11 1/2"	11 1/2"

Lacing: 3 cross both sides for 28" front

3 cross on small flange and 2 cross on large flange for 26" front.

All Rears 4 cross both sides.

Manufacturers recommend the use of 14G spokes when building.

PRICES shown do NOT include PURCHASE TAX which will be charged at current rates where applicable

Branches
Aberdeen, Aston, Belfast
Birmingham, Bournemouth
Bristol, Cardiff, Centre
Croydon, Dublin, Dundee
Exeter, Glasgow
Hull, Ipswich, Leeds

Head Office and Warehouse. Wholesale only:

GREAT EASTERN STREET, LONDON, E.C.2

126 GEORGE STREET EDINBURGH, 2

Branches
Liverpool, Manchester
Newcastle-upon-Tyne
Nottingham, Oxford, Preston
Reading, Southampton
Sheffield, Wakefield
Wolverhampton

MUDGUARDS (Celluloid, Alloy)—continued

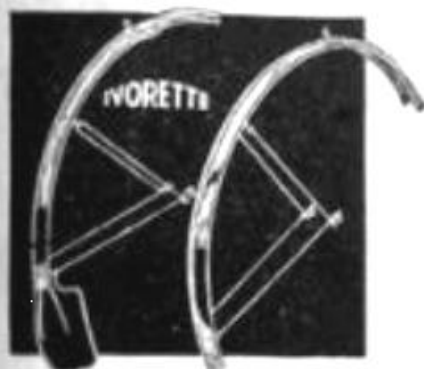
IVOLETTE CELLULOID
MUDGUARDS

Complete with rustless stays, domed head nuts and fittings for brazed on eye fitting. With built in Mudflap.

1 1/2" wide, narrow ribbed section with spear-point front extension.

All White.

No. 25/M164a/904 .. per pair 14/-

2 1/4" wide, plain domed section with ordinary Front Extension.

All White.

No. 25/M164g/904 .. per pair 14/-



"BRITAN-NIAL"

ALLOY LIGHTWEIGHT MUDGUARDS

Standard pattern, 2 1/4" ribbed section with Ordinary Front Extension complete with rust-proof stays, T bolts and wing nuts for brazed-on eye fitting and mud flap.

Polished.

No. 25/M186e/704 .. per pair 11/-

Polished (with Reflector fitted).

No. 25/M186f/800 .. per pair 12/-

"BANTEL" CELLULOID
MUDGUARDS

With ordinary front extension and built in Mudflap, complete with rustless stays, less wing nuts and bolts.

Super Sports

7" Wide Ribbed Section.

All White. (C314.)

No. 25/M168f/810 .. per pair 13/3

All White with Rear Reflector. (C315.)

No. 25/M168g/906 .. per pair 14/3

"BANTEL" ALLOY LIGHTWEIGHT
Domed section size 2 1/4" with centre rib and ordinary front extension. With rustless stays and fittings, less wing nuts and clips.

Polished Finish. (C257.)

No. 25/M183w/ .. per pair

BLUEMEL'S "AIRWEIGHT"
ALLOY MUDGUARDS

Highly polished light alloy mudguard, domed section with centre rib and built in Mudflap on front. Complete with rustless fittings, each pair individually wrapped.

With Spearpoint Extension.

Cadmium Plated Stays.

No. 25/M183lc/900 .. per pair 13/6

With Ordinary Extension.

Cadmium Plated Stays.

No. 25/M183mc/900 .. per pair 13/6

BLUEMEL'S "CONTINENTAL"
ALLOY MUDGUARDS

Highly polished light alloy mudguards, narrow section, size 1 1/2" with rib down centre and side valances. Built in Mudflap on front complete with rustless fittings and Cadmium plated stays. Each pair individually wrapped.

With Ordinary Extension.

No. 25/M183nc/904 .. per pair 14/-

Complete with Reflector.

No. 25/M183nr/7002 .. per pair 15/3

With Spearpoint Extension.

No. 25/M183p/904 .. per pair 14/-

Complete with Reflector.

No. 25/M183pr/7002 .. per pair 15/3

BLUEMEL'S "TOUR DE FRANCE"
ALLOY MUDGUARDS

Highly polished light alloy Mudguard, suitable for either 26" or 27" wheels. Narrow domed section 1 1/2" wide, and built in Mudflap. Complete with rustless fittings.

Ordinary Front Extension.

Cadmium Plated Stays.

No. 25/M183tc/904 .. per pair 14/-

Complete with reflector.

No. 25/M183tr/7006 .. per pair 15/9

PRICES shown do NOT include PURCHASE TAX which will be charged at current rates where applicable

Branches
Aberdeen, Aston, Belfast
Birmingham, Bournemouth
Bristol, Cardiff, Carlisle
Croydon, Dublin, Dundee
Exeter, Glasgow
Hull, Ipswich, Leeds

Head Office and Warehouse, Wholesale only

GREAT EASTERN STREET, LONDON, E.C.2

134 GEORGE STREET EDINBURGH 3

Branches
Liverpool, Manchester
Newcastle-upon-Tyne
Nottingham, Oxford, Preston
Reading, Southampton
Sheffield, Stoke-on-Trent
Wolverhampton

PEDALS



"B.S.A."

RACING RAT TRAP

Chromium Plated.

No. 25/P28b/1108 .. per pair 15/6

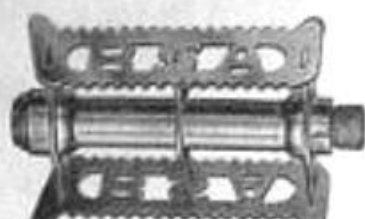

"B.S.A." RAT TRAP

Solid Centre.

Chromium Plated.

No. 25/P29/706 .. per pair 10/-

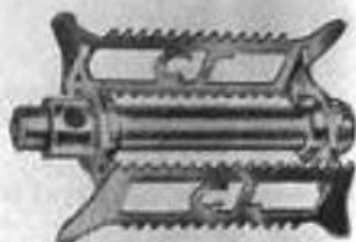

CHATER-LEA

RACING RAT TRAP

Spindles with hole for tommybar fitting
Chromium Plated.

No. 25/P89c/1801½ .. per pair 25/-



BRAMPTON SOLID CENTRE

RACING RAT TRAP

3½" wide with slot for toe straps.

Chromium Plated. (B8.)

No. 25/P49g/1001 .. per pair 15/-

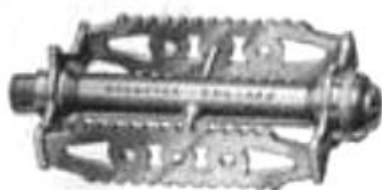

BRAMPTON HYDUMINIUM

RACING LIGHTWEIGHT

3½" wide

Chromium Plated. (546.)

No. 25/P49m/1109 .. per pair 17/6

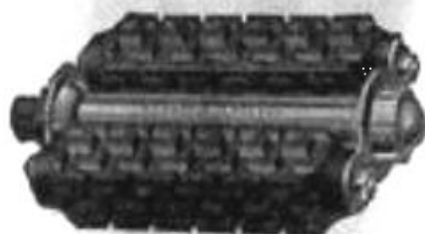

BRAMPTON

UNIVERSAL SINGLE RUBBER

Chromium Plated.

3½" wide. (11.)

No. 25/P58b/504 .. per pair 8/-

4" wide. (10.)

No. 25/P58d/504 .. per pair 6/-

4½" wide. (14.)

No. 25/P58f/502 .. per pair 9/3

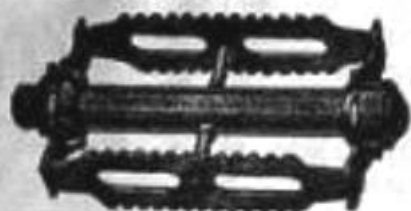

BRAMPTON

UNIVERSAL RAT TRAP

4" wide.

Chromium Plated. (22.)

No. 25/P53c/405 .. per pair 6/7



BRAMPTON

UNIVERSAL JUVENILE RUBBER

3" wide.

Chromium Plated. (12.)

No. 25/P55/501 .. per pair 7/7½



BRAMPTON

TRADESMAN'S CARRIER

(600.)

4½" wide. All black.

No. 25/P58w/704 .. per pair 11/-



BRAMPTON UNIVERSAL

RACING RAT TRAP

(20.)

Chromium Plated.

No. 25/P64b/502 .. per pair 7/9

PRICES shown do NOT include PURCHASE TAX which will be charged at current rates where applicable

Branches
Aberdeen, Accrington, Belfast
Birmingham, Bournemouth
Bristol, Cardiff, Carlisle
Croydon, Dublin, Dundee
Glasgow, Leicester, London
Manchester, Newcastle

Head Office and Warehouse: Wholesale only:

GREAT EASTERN STREET, LONDON, E.C.2

136 GEORGE STREET EDINBURGH 1

Branches
Liverpool, Manchester
Newcastle-upon-Tyne
Nottingham, Oxford, Preston
Reading, Southampton
Sheffield, Tyneside
Wolverhampton

PEDALS—continued



PHILLIPS

"ANGLO" RACING RAT TRAP

Chromium Plated. (55.)

No. 25/P210/611 .. per pair 10/4



PHILLIPS

"ANGLO" SINGLE RUBBER

Chromium Plated.

3½" wide. (46.)

No. 25/P216g/701 .. per pair 10/7

4" wide. (45.)

No. 25/P216k/701 .. per pair 10/7

PHILLIPS "ANGLO"
HEAVY BLOCK RUBBER

Chromium Plated.

4½" wide. (81.)

No. 25/P220b/808 .. per pair 13/-

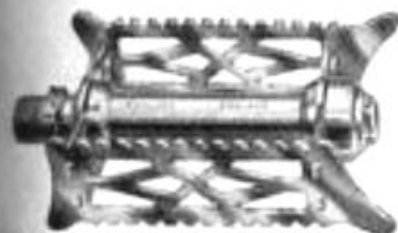

PHILLIPS

"APOLLO" RACING RAT TRAP

Chromium Plated. (83.)

No. 25/P222m/502 .. per pair 7/9



PHILLIPS "GELTONIA" RAT TRAP

Chromium Plated.

4" wide. (61.)

No. 25/P226k/405 .. per pair 6/7

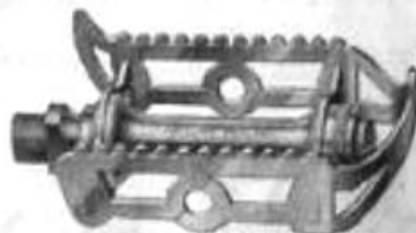
PHILLIPS "CREDALUX"
SOLID CENTRE RAT TRAP

Chromium Plated. (101.)

No. 25/P232c/1008 .. per pair 16/-

PHILLIPS "PHILITE"
LIGHTWEIGHT RUSTLESSSolid die-cast centre of aluminium alloy with
U type frame of stainless steel.

(333.)

No. 25/P232k/1106 .. per pair 17/3



PHILLIPS

"PHILITE" RUBBER TREAD

Solid die-cast centre of aluminium alloy with
removable moulded rubber treads.

(102.)

No. 25/P232l/710 .. per pair 11/9

(157.)

As above but with reflector eye on each side
plate.

No. 25/P232m/901 .. per pair 13/7

PHILLIPS TRIPLE STUD RUBBER

Chromium Plated.

3½" wide. (201.)

No. 25/P238g/507 .. per pair 8/4

4" wide. (200.)

No. 25/P238k/507 .. per pair 8/4



PHILLIPS

"PHILITE" LIGHTWEIGHT

Constructed with aluminium alloy with
narrow hardened steel strips fitted to all
wearing surfaces.

(166.)

No. 25/P232p/904 .. per pair 14/-

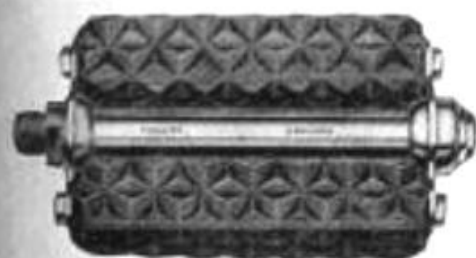

PHILLIPS

"CELTONIA" SINGLE RUBBER

Chromium Plated.

3½" wide. (66.)

No. 25/P236g/504 .. per pair 8/-

4" wide. (65.)

No. 25/P236k/504 .. per pair 8/-



PHILLIPS "CREDEX"

JUVENILE SINGLE RUBBER

Chromium Plated.

3" wide. (58.)

No. 25/P233c/411 .. per pair 7/4

FOR PEDAL TAPS
AND BUSHES
Refer to page 58.

PRICES shown do NOT include PURCHASE TAX which will be charged at current rates where applicable

Branches
Aberdeen, Aston, Belfast
Birmingham, Bournemouth
Bristol, Cardiff, Carlisle
Croydon, Dublin, Dundee
Exmouth, Glasgow
Hull, Inverness, Leeds

Head Office and Warehouse, Wholesale only

GREAT EASTERN STREET, LONDON, E.C.2

121 GEORGE STREET EDINBURGH, 3

Branches
Liverpool, Manchester
Newcastle-upon-Tyne
Nottingham, Oxford, Preston
Reading, Southampton
Stoke-on-Trent
Wolverhampton

SADDLES

BROOKS LIGHTWEIGHT CHAMPION AND RACING

Models B27, B37, B47 and B57 only.

A range of Racing Saddles for the Sportsman, constructed of Lightweight non-corrosive material, stainless steel wires and other parts heat treated light alloy. Made from best Butt Leather with solid copper rivets.



BROOKS B27

Sports Two-wire Base Frame.

Size 11" x 6 1/2" x 3 1/4".

Weight 1 lb. 4 oz.

No. 25/S125n/3708 each 56/6



BROOKS B37

Narrow Sports Two-wire Base Frame.

Size 11" x 6" x 3 1/4".

Weight 1 lb. 3 oz.

No. 25/S125p/3708 each 56/6



BROOKS B47

Two-wire Sprinter Base Frame.

Size 11" x 4 1/2" x 2 1/4".

Weight 1 lb. 2 oz.

No. 25/S125r/3708 each 56/6



BROOKS B17

CHAMPION STANDARD

Sports Two-wire Base Frame.

Size 11" x 6 1/2" x 3 1/4".

Weight 1 lb. 12 oz.

Black Enamelled.

No. 25/S125c/3208 each 49/-

Chrome Plated.

No. 25/S125cc/3406 each 51/9



BROOKS B15 SPORTS

Two-wire Base Frame.

Size 11" x 6 1/2" x 3 1/4".

Weight 1 lb. 11 oz.

Black Enamelled.

No. 25/S124/2306 each 35/3

Chrome Plated.

No. 25/S124cc/2504 each 38/-



BROOKS B57

Super Sports Two-wire Frame.

Size 11" x 6" x 3 1/4".

Weight 1 lb. 3 oz.

No. 25/S125t/5000 each 75/-



BROOKS B17S

CHAMPION SPRINTER

Sports Two-wire Base Frame.

Size 11" x 4 1/2" x 2 1/4".

Weight 1 lb. 7 oz.

Black Enamelled.

No. 25/S125m/3209 each 49/-

Chrome Plated.

No. 25/S125mc/3406 each 51/9



BROOKS B17

CHAMPION NARROW

Sports Two-wire Base Frame.

Size 11" x 6" x 3 1/4".

Weight 1 lb. 10 oz.

Black Enamelled.

No. 25/S125d/3208 each 49/-

Chrome Plated.

No. 25/S125dc/3406 each 51/9

FOR

BROOKS

SADDLE SPARES

Refer to pages 208-209.

PRICES shown do NOT include PURCHASE TAX which will be charged at current rates where applicable

Branches:
Aberdeen, Arona, Belfast
Birmingham, Bournemouth
Bristol, Cardiff, Carlisle
Croydon, Dublin, Dundee
Exeter, Glasgow, Ipswich,
Leeds

Head Office and Warehouse, Wholesale only:

GREAT EASTERN STREET, LONDON, E.C.2

114 GEORGE STREET EDINBURGH. 1

Branches:
Liverpool, Manchester
Newcastle-upon-Tyne
Nottingham, Oxford, Preston
Reading, Southampton
Tulane, Truro
Wolverhampton

SADDLES—continued
BROOKS—continued, DUNLOP



BROOKS B10/2 TOURIST

Four-wire Base Frame.
Enamelled.

Size 11½" × 9½" × 2½".
Weight 2 lb.

No. 25/S121d/3200 each 48/-



BROOKS B72 TOURIST

Four-wire Base Frame.
Size 10½" × 8½" × 2½".
Weight 1 lb. 11 oz.

Ladies' Model (B72L).

Black Enamelled.

No. 25/S126d/2406 each 36/9

Chrome Plated.

No. 25/S126dc/2606 each 39/9

Gent's Model (B72G).

Black Enamelled.

No. 25/S126e/2406 each 36/9

Chrome Plated.

No. 25/S126ec/2606 each 39/9



BROOKS B73 TOURIST

Four-wire Base Frame with three-coil springs.
Size 10½" × 8½" × 3½".
Weight 2 lb. 6 oz.

Gent's Model (B73G).

Black Enamelled.

No. 25/S129c/2406 each 36/9

Chrome Plated.

No. 25/S129cc/2606 each 39/9

Ladies' Model (B73L).

Black Enamelled.

No. 25/S129d/2406 each 36/9

Chrome Plated.

No. 25/S129dc/2606 each 39/9



BROOKS B66 TOURIST

Four-wire Base Frame with two-coil springs.

Size 10½" × 8½" × 2½".
Weight 2 lb. 5 oz.

Gent's Model (B66G)

Black Enamelled.

No. 25/S130d/2406 each 36/9

Chrome Plated.

No. 25/S130dc/2606 each 39/9

Ladies' Model (B66L).

Black Enamelled.

No. 25/S130e/2406 each 36/9

Chrome Plated.

No. 25/S130ec/2606 each 39/9

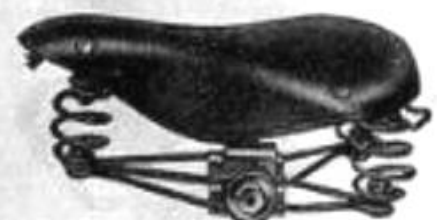

BROOKS J3 JUVENILE

Three-coil with ½" clip.
Size 9" × 6½" × 3½".
Weight 1 lb. 10 oz.

No. 25/S130r/1000 each 15/-



BROOKS JUVENILE

Model J5.

Four-wire with Standard clip.
Size 10½" × 6½" × 2".
Weight 1 lb. 7 oz.

No. 25/S130w/1110 each 20/9

Model J4.

Four-wire with Standard clip.
Size 9" × 6½" × 3½".

No. 25/S130v/1008 each 16/-



BROOKS HEAVY DUTY

Loop Front and Six-wire Base Frame.

Model (B90/2.)

Size 11½" × 9½" × 4½".
Weight 3 lb. 12 oz.

No. 25/S132b/4202 each 63/6

Model (B90/3.)

Size 12" × 9½" × 4½".
Weight 4 lb. 8 oz.

No. 25/S132c/4602 each 69/3



**DUNLOP D6
LIGHT ROADSTER**

Four-wire.
Size 10" × 8".
Weight 1 lb. 14 oz.

No. 25/S160f/904 each 14/-



**DUNLOP D7
LIGHT ROADSTER**

Four-wire and Three Coils.
Size 10" × 8".
Weight 2 lb. 7 oz.

No. 25/S160g/1000 each 15/-

PRICES shown do NOT include PURCHASE TAX which will be charged at current rates where applicable

Branches:
Aberdeen, Arona, Belfast
Birmingham, Bournemouth
Bristol, Cardiff, Carlisle
Croydon, Dublin, Dundee
Exeter, Glasgow
Hull, Ipswich, Leeds

Head Office and Warehouse, Wholesale only:

GREAT EASTERN STREET, LONDON, E.C.2

116 GEORGE STREET EDINBURGH, 2

Branches:
Liverpool, Manchester
Newcastle-upon-Tyne
Nottingham, Oxford, Preston
Reading, Southampton
Sheffield, Trent
Wolverhampton

SADDLES—continued

DUNLOP—continued, LEATHERIES



DUNLOP D8 ROADSTER

Four-wire and Loop Front.

Size 10" x 8".

Weight 2 lb. 9 oz.

No. 25/S160b/1004 each 18/6



DUNLOP D18 ROADSTER

Six-wire and Loop Front.

Size 10" x 8".

Weight 2 lb. 12 oz.

No. 25/S160l/1008 each 16/-



DUNLOP M11 ROADSTER

Four-wire.

Size 10½" x 8½".

Weight 2 lb.

No. 25/S161c/1108 each 17/6



DUNLOP M15 ROADSTER

Three-coil and Four-wire.

Size 10½" x 8½".

Weight 2 lb. 10 oz.

No. 25/S161g/1204 each 18/6

DUNLOP G17 CLUB MODEL

Sports two-wire Frame

Standard size 11" x 6½"

25/S160c/1500 each 22/6

Narrow Size 11" x 6"

25/S160d/1500 each 22/6

Sprint Size 11" x 4½"

25/S160e/1500 each 22/6



DUNLOP S3 JUVENILE.

Two-wire Girder and Two Springs with 1" Clip.

Size 8" x 6½".

Weight 1 lb. 5 oz.

No. 25/S162e/604 each 9/6

With 1" Adult Clip.

No. 25/S162f/604 each 9/6

"LEATHERIES" L36/3
HEAVY DUTY

Loop Front, Six-wire.

Size 11½" x 9½" x 4½".

Weight 3 lb. 7 oz.

No. 25/S180r/2604 each 39/6



DUNLOP S1 JUVENILE

Two-wire Frame with ring Clip.

Size 8" x 6½".

Weight 1 lb.

No. 25/S162n/504 each 8/-



"LEATHERIES" L21 TOURIST

Four-wire.

Size 10" x 8½" x 2½".

Weight 1 lb. 11 oz.

Gent.'s Model (L21G)

No. 25/S181k/1608 each 25/-

Ladies' Model (L21L).

No. 25/S181l/1608 each 25/-

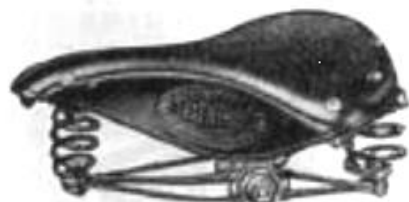
"LEATHERIES" L20
TOURIST

Three Coil.

Size 10½" x 8½" x 3½".

Weight 2 lb. 4 oz.

Gent.'s Model (L20G).

No. 25/S181p/1608 each 25/-

Ladies' Model (L20L).

No. 25/S181r/1608 each 25/-



"LEATHERIES" L404 RACE

Four-wire Narrow.

Size 11½" x 6" x 2½".

Weight 1 lb. 7 oz.

No. 25/S181c/1506 each 23/3

FOR SADDLE SPARES

Refer to pages 208-210.

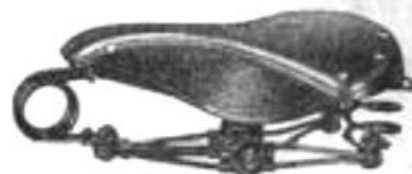
"LEATHERIES" L414
HEAVY DUTY

Loop Front and Two-coil.

Size 10½" x 8½" x 3½".

Weight 2 lb. 5 oz.

No. 25/S181w/1704 each 26/-

PRICES shown do NOT include PURCHASE TAX which will be charged at current rates where applicable

Branches
Aberdeen, Aston, Belfast
Birmingham, Bournemouth
Bristol, Cardiff, Carlisle
Croydon, Dublin, Dundee
Exeter, Glasgow
Hull, Ipswich, Leeds

Head Office and Warehouse, Wholesale only

GREAT EASTERN STREET, LONDON, E.C.2

126 GEORGE STREET EDINBURGH. 1

Branches
Liverpool, Manchester
Newcastle-upon-Tyne
Nottingham, Oxford, Preston
Reading, Southampton
Sheffield, Truro
Wolverhampton

SEAT PILLARS SHOE PLATES SHOW PRICE CARDS, ETC.

A & P "HAPPY MEDIUM" SEAT PILLARS

For $\frac{1}{2}$ " Saddle Clips 12" long.

Chromium Plated.

No. 25/S556a/404	$\frac{1}{2}$ " stem	each 6/6
25/S556c/404	$\frac{3}{8}$ "	6/6
25/S556e/404	1"	6/6
25/S556g/404	$1\frac{1}{2}$ "	6/6
25/S556k/404	$1\frac{3}{4}$ "	6/6
25/S556m/404	$1\frac{7}{8}$ "	6/6
25/S556p/404	$1\frac{9}{16}$ "	6/6

"L" PATTERN SEAT PILLARS

For $\frac{1}{2}$ " Saddle Clips.

Chromium Plated.

"A & P" Best Quality.

7" long x 4 $\frac{1}{2}$ " tops.Stock sizes: $\frac{1}{2}$ ", $\frac{3}{8}$ ", 1", $1\frac{1}{2}$ ", $1\frac{3}{4}$ " and $1\frac{7}{8}$ "

No. 25/S550L/507 each 8/5

12" long x 6" tops.

Stock sizes: $\frac{1}{2}$ ", $\frac{3}{8}$ ", 1", $1\frac{1}{2}$ " and $1\frac{7}{8}$ "

No. 25/S550p/610 each 10/3

CYCLO ROSALOY
"OPPY" SHOE PLATES

With single groove.

Black Enamelled Steel.

No. 25/S680p/102 pair 1/9

Light Alloy.

No. 25/S680pa/102 pair 1/9

"SIMPLEX" SHOE PLATES WITH DOUBLE GROOVE

 $2\frac{1}{2}$ " diameter circular made from special hard-wearing flexible rubber with 12 small holes to bond on soles.

Made in France.

Packed on Show Display Cards of 6 pairs.

No. 25/S680r/900 per card of six pairs 13/6

STRAIGHT SEAT PILLARS

"A. & P"

Chromium Plated.

Stock sizes: $\frac{1}{2}$ ", $\frac{3}{8}$ ", 1", $1\frac{1}{2}$ ", $1\frac{3}{4}$ ", and $1\frac{7}{8}$ " stems.

No. 25/S570p/300 12" long each 4/8

Strata High Tensile Aluminium Alloy.

For $\frac{1}{2}$ " clips. 12" long x $1\frac{1}{2}$ " dia.

Polished Finish.

No. 25/S606g/300 each 4/6

Reynolds Hyduminium RR.56 Aluminium Alloy.

12" long. Polished Finish.

No. 25/S625d/305 1" dia. stem. each 5/2

25/S625e/305 $1\frac{1}{2}$ " stem. 5/225/S625f/305 $1\frac{3}{4}$ " or 1-043" stem. 5/225/S625g/305 $1\frac{7}{8}$ " stem. 5/2

25/S625h/305 1-072" to 1-075" stem. 5/2

TERRY'S SHOW PRICE TICKET CLIP

Spring steel, Black Enamelled.

To fit $\frac{1}{2}$ " and 1" tubes.

No. 25/S718b/208 per doz. 4/-

No. 49034 REPAIR TICKET No. 49034

Name _____ This Ticket must be given
as in Exchange for Repair

Repairs.

REPAIRS _____

Price _____

Price _____

Calling _____

DUPLICATE REPAIR LABELS OR TAGS

Good quality Manilla, perforated and double numbered, 1 to 1000 or more, used extensively for Cycle, Motor, Radio, Electrical, Perambulator and Gramophone Trades, etc.

Size 4 $\frac{1}{2}$ " x 2 $\frac{1}{2}$ ".

No. 25/S731r/1506 per 1000 23/3

WHITE EXONITE CELLULOID BLANK SHOW PRICE TICKETS

Size 2 $\frac{1}{2}$ " x 1" with $\frac{1}{8}$ " hole.

Prices and descriptions can be written on with pencil and cleaned off as required. This ticket can be used for general repairs, or for attaching to accumulators for recharging, etc.

Packed in boxes of 1 gross.

No. 25/S740e/504 per box 8/-

PRICES shown do NOT include PURCHASE TAX which will be charged at current rates where applicable

Branches
Aberdeen, Aston, Belfast
Birmingham, Southampton
Bristol, Cardiff, Carlisle
Croydon, Dublin, Dundee
Leeds, Liverpool, Glasgow
Hull, Manchester, Leeds

Head Office and Warehouse, Wholesale only

GREAT EASTERN STREET, LONDON, E.C. 2

126 GEORGE STREET EDINBURGH, 2

Branches
Liverpool, Manchester
Newcastle-upon-Tyne
Nottingham, Oxford, Preston
Reading, Southampton
Sheffield, Tyneside
Wolverhampton

TOE CLIPS—continued

ASHBY "WANDERLUST"
TOE CLIPS.

With fine adjustable fitting plates over 2" to suit individual rider.

Nickel Plated, without Straps.

No. 25/T172L/203 (No. 15) per pair 3/4

Chromium Plated, with Chrome Straps.

No. 25/T172m/408 (No. 15C.) per pair 7/-

Chromium Plated, without straps.

No. 25/T172n/300 (No. 15EC.) per pair 4/6

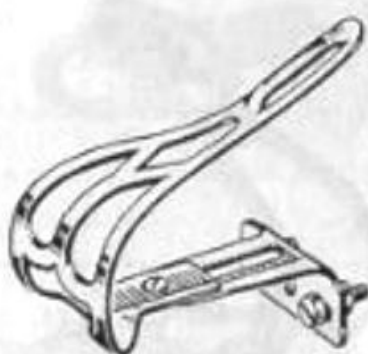

CATOS TOE CLIPS

Adjustable.

With serrated base plates for adjustment.

Polished Light Alloy.

No. 25/T173h/210 .. per pair 4/3

Chromium Plated.

No. 25/T173L/304 .. per pair 5/-

Non-adjustable.

Light spring steel.

Chromium Plated.

No. 25/T173c/304 .. per pair 5/-

Dight Plating.

No. 25/T173d/200 .. per pair 3/-

FOR SHOE PLATES

see Page 211

CYCLO "OPPY" PATTERN
SPRING STEEL WIRE TOE CLIPS

Black Finish.

Complete with two bolts, nuts and washers, to suit various widths and patterns of rat-trap pedals. With two loops to take straps. Very light.

British made. Less Straps.

No. 25/T174g/110 .. per pair 2/9



BROOKS TOE CLIPS

Light spring steel, Chromium Plated.

Non-adjustable. (3.)

No. 25/T174n/206 .. per pair 3/9

Adjustable. (7.)

No. 25/T174r/300 .. per pair 4/6



STRATA TOE CLIPS

Light spring steel to take toe strap.

Non-adjustable. Stainless Steel.

Short Pattern. (3S.)

No. 25/T175a/308 .. per pair 5/6

Long Pattern (Continental). (3P.)

No. 25/T175c/308 .. per pair 5/6



STRATA TOE CLIPS

With serrated plates for adjustment. To take toe straps.

Chrome Plated. Weight 4 oz. (2AS.)

No. 25/T175d/300 .. per pair 4/6

Polished Light Alloy. Weight 2½ oz. (2AA.)

No. 25/T175h/208 .. per pair 4/-



STRATA TOE CLIPS

Non-adjustable. To take toe straps.

Chromium Plated. Weight 3 oz. (2.)

No. 25/T175e/200 .. per pair 3/-

Polished Light Alloy. Weight 1 oz. (2A.)

No. 25/T175g/200 .. per pair 3/-

PRICES shown do NOT include PURCHASE TAX which will be charged at current rates where applicable

Branches
Aberdeen, Ayr, Belfast
Birmingham, Bournemouth
Bristol, Cardiff, Cardiff
Crawley, Dublin, Dundee
Exeter, Glasgow
Hull, Ipswich, Leeds

Head Office and Warehouse, Wholesale only

GREAT EASTERN STREET, LONDON, E.C.2

124 GEORGE STREET EDINBURGH, 2

Branches
Liverpool, Manchester
Newcastle-upon-Tyne
Nottingham, Oxford, Preston
Reading, Southampton
Sheffield, Truro
Wolverhampton

BICYCLE FRAMES

PHILLIPS
REPLACEMENT
FRAMES

Phalrace Lightweight (coloured).

Entirely brazed-up with cut-out lugs, "D" to round front forks, expander head, and lamp bracket. Complete with chain wheel and cranks, seat pillar and mudguards.

Stock sizes and colours.

Gent.'s 22"/26"	} Pastel shades.
Lady's 21"/26"	
No. 27/76a/7911	Gent.'s each 106/6
27/76b/8301	Lady's .. 110/9

AYLEY
REPLACEMENT
FRAMES ONLY

(Less Chain Wheels and Cranks.)



Sports (Coloured). Gent.'s. Entirely brazed-up, with cut-away lugs. Front forks "D" to round, forward rake, solid front fork ends, brazed-on front mud-guard eyes. Fitted-up head and bottom bracket. (Less mudguards, seat pillar, chain wheel and cranks.)

Stock size and colours:

22"/26". Polychromatic Blue or Green.
No. 27/81a/8810 each 133/3



Sports (Coloured).

Lady's (Two straight tubes).

Entirely brazed-up with cut-away lugs. Front forks "D" to round, forward rake, solid front fork ends, brazed-on front mud-guard eyes. Fitted-up head and bottom bracket. (Less mudguards, seat pillar, chain wheel and cranks.)

Stock size and colours:

21"/26". Polychromatic Blue or Green.
No. 27/81b/9100 each 136/6

Sports (Coloured.)

With Reynolds "531" Frame Tubes

(Gent.'s only.)

Entirely brazed-up tapered seat and chain stays, cut-away and fishtailed lugs. Front forks "D" to round. Forward rake with solid ends, chromium plated front and rear fork ends and crown. Brazed-on front mud-guard eyes, and lamp bracket boss. Expander head. Fitted-up head and bottom bracket (less mudguards, seat pillar, chain wheel and cranks.)

Stock size and colours.

23"/26". Polychromatic Blue, Green, or Red.
No. 27/83a/13102 each 196/9



Roadster—(Cranked Stay).

Gent.'s. Black and Lined Red/Gold.

Fitted-up head and bottom bracket. (Less mudguards, seat pillar, chain wheel and cranks.)

Stock size 22"/26".

No. 27/84a/5704 each 86/-

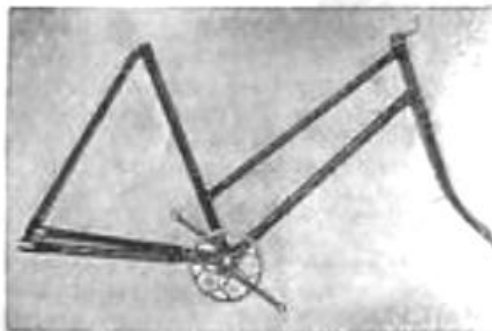

Roadster—(Cranked Stay).

Lady's Black and Lined Red/Gold.

Fitted-up head and bottom bracket. (Less mudguards, seat pillar, chain wheel and cranks.)

Stock size 21"/26".

No. 27/84b/5806 each 89/3

PRICES shown do NOT include PURCHASE TAX which will be charged at current rates where applicable

Branches:
Aberdeen, Acton, Belfast
Birmingham, Bournemouth
Bristol, Cardiff, Carlisle
Croydon, Dublin, Dundee
Exeter, Glasgow
Hull, Ipswich, Leeds

Head Office and Warehouse. Wholesale only.

GREAT EASTERN STREET, LONDON, E.C.2

114 GEORGE STREET EDINBURGH, 1

Branches:
Liverpool, Manchester
Newcastle-upon-Tyne
Nottingham, Oxford, Preston
Reading, Southampton
Sheffield, Stockport
Wolverhampton

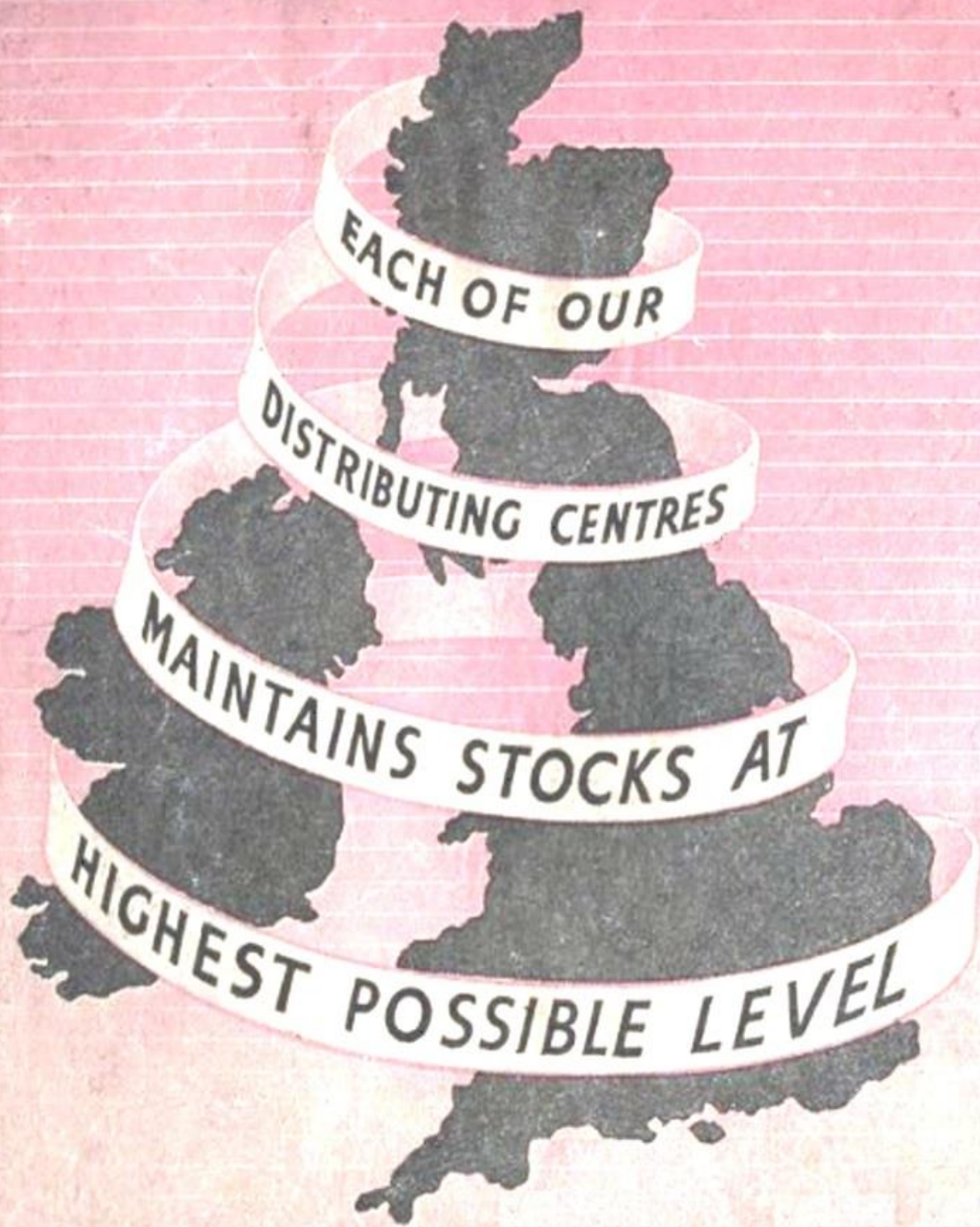

Brown Brothers Limited

ALLIED COMPANIES

THOMSON AND BROWN BROTHERS LIMITED

BROWN BROTHERS (AIRCRAFT) LTD.

BROWN BROTHERS (IRELAND) LTD.